

UNIVERSITY OF THE WESTERN CAPE

Energy Optimization for Wireless Sensor Networks  
using Hierarchical Routing Techniques

by

Ademola Philip Abidoeye

a thesis submitted in fulfilment of the  
requirements for the degree of

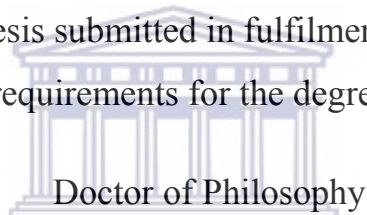

Doctor of Philosophy

UNIVERSITY of the  
WESTERN CAPE

in  
Computer Science

Faculty of Natural Sciences

Department of Computer Science

November 2014

## Declaration of Authorship

I declare that *Energy Optimization for Wireless Sensor Networks using Hierarchical Routing Techniques* is my own work, that it has not been submitted for any degree or examination in any other university. I also declare that all the sources I have used or cited have been indicated and acknowledged by complete references.

Ademola Philip Abidoeye

November 2014

Signed: -----



# DEDICATION

This project is dedicated to

*my wonderful wife – Olanike Elizabeth, Abidoje*

*and*

*my children – {Oluwatosin, Olumide, and Oluwaferanmi} Abidoje*



## List of Abbreviations and Meanings

| Acronym       | Meaning   |
|---------------|---|
| WSNs          | Wireless Sensor Networks  |
| S-MAC         | Sensor MAC  |
| MAC           | Medium Access Protocol  |
| QoS           | Quality of Service  |
| RTS/CTS       | Ready to Send/Clear to Send   |
| TDMA          | Time Division Multiple Access   |
| CSMA          | Carrier Sense Multiple Access   |
| ADV           | Advertisement Message   |
| $R_m$         | Set of routing configurations   |
| $G_k$         | A cluster   |
| ID            | Identification Document   |
| $C_k$         | Average number of sensor nodes per cluster                            |
| BS            | Base station  |
| FND           | First Node Dies   |
| LND           | Last Node Dies  |
| K             | Number of Clusters  |
| $d_0$         | Threshold distance value  |
| $V$           | Number of Sensor nodes  |
| $q_i$         | Data transmitted by individual sensor node                            |
| $q_k$         | Data packets size   |
| $E_i$         | Initial energy of a sensor node                                       |
| $E_F$         | Data fusion energy  |
| M             | Network length  |
| CHs           | Cluster heads   |
| $\check{r}$   | Number of rounds  |
| $t_N$         | Network lifetime  |
| $SD_{min}$    | Minimum Separation Distance   |
| ACO           | Ant Colony Optimization   |
| $N_A$         | Advanced Node   |
| $r$           | Sensor node maximum transmission distance                             |
| $E_T$         | Cluster head threshold energy   |
| $p$           | Fraction of the advanced nodes  |
| $N_n$         | Normal node   |
| $\check{a}_j$ | Amount of data at node $j$  |
| $W(y)$        | Weight of sensor node $y$ based on the distance from the base station |
| $S(x)$        | Sensor node service delivery  |
| $R$           | Communication range of a relay node                                   |
| $C_j$         | Concentric circle   |
| $\check{E}_i$ | Residual energy of a sensor node                                      |
| $N_i$         | Neighbour nodes of sensor node $i$                                    |

# UNIVERSITY OF THE WESTERN CAPE

## Abstract

Department of Computer Science

Doctor of Philosophy

by

Ademola Philip Abidoye

Supervisor: Prof. Antoine B. Bagula

Wireless sensor networks (WSNs) have become a popular research area that is widely gaining the attraction from both the research and the practitioner communities due to their wide area of applications. These applications include real-time sensing for audio delivery, imaging, video streaming, and remote monitoring with positive impact in many fields such as precision agriculture, ubiquitous healthcare, environment protection, smart cities and many other fields. While WSNs are aimed to constantly handle more intricate functions such as intelligent computation, automatic transmissions, and in-network processing, such capabilities are constrained by their limited processing capability and memory footprint as well as the need for the sensor batteries to be cautiously consumed in order to extend their lifetime. This thesis revisits the issue of the energy efficiency in sensor networks by proposing a novel clustering approach for routing the sensor readings in wireless sensor networks. The main contribution of this dissertation is to 1) propose corrective measures to the traditional energy model adopted in current sensor networks simulations that erroneously discount both the role played by each node, the sensor node capability and fabric and 2) apply these measures to a novel hierarchical routing architecture aiming at maximizing sensor networks lifetime. We propose three energy models for sensor network: a) a service-aware model that account for the specific role played by each node in a sensor network b) a sensor-aware model and c) load-balancing energy model that accounts for the

sensor node fabric and its energy footprint. These two models are complemented by a load-balancing model structured to balance energy consumption on the network of cluster heads that forms the backbone for any cluster-based hierarchical sensor network. We present two novel approaches for clustering the nodes of a hierarchical sensor network: a) a distance-aware clustering where nodes are clustered based on their distance and the residual energy and b) a service-aware clustering where the nodes of a sensor network are clustered according to their service offered to the network and their residual energy. These approaches are implemented into a family of routing protocols referred to as EOCIT (Energy Optimization using Clustering Techniques) which combines sensor node energy location and service awareness to achieve good network performance. Finally, building upon the Ant Colony Optimization System (ACS), Multipath Routing protocol based on Ant Colony Optimization approach for Wireless Sensor Networks (MRACO) is proposed as a novel multipath routing protocol that finds energy efficient routing paths for sensor readings dissemination from the cluster heads to the sink/base station of a hierarchical sensor network. Our simulation results reveal the relative efficiency of the newly proposed approaches compared to selected related routing protocols in terms of sensor network lifetime maximization.

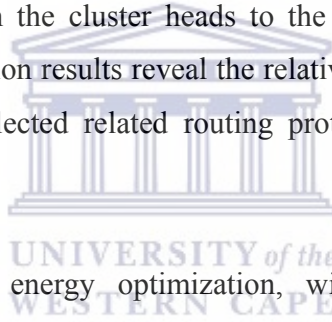

**Keywords:** sensor nodes, energy optimization, wireless sensor networks (WSNs), clustering, energy holes, service differentiation, ant colony optimization (ACO), hierarchical routing, and energy model.

## Acknowledgements

First, I give thanks to Almighty God for given me the grace to successfully complete this programme. All Glory and Adoration go to Him alone.

My appreciation goes to Prof. Antoine B. Bagula for his assistance, contributions, encouragement, and fatherly role he played towards the completion of this thesis. Without him, I would have been lost in the wilderness of research.

I acknowledge Prof. Ian Cloete for his contributions, and suggestions towards the end of this research.

I would like to thank Prof. Isabella Venter, Computer Science Head of Department (HOD) for her concern and intervention when I was at the cross road.

My thanks go to the staff members of Computer Science Department for their support throughout my period in the Department. They are Mr Daniel Leendert, Ms Rene Abbott, and Ms Fatima Jacobs-Samsodien.

Special thanks go to the Division for Postgraduate Studies (DPGS) for given me the opportunity to be one of the writing coaches throughout my programme.

I thank my colleagues in the PhD research Lab - Dr Nureni A. Azeez, Dr Ademola O. Adesina, Dr Kehinde K. Agbele, Mr. Hope R. Mauwa, and my dearest friend Mr. George Agbo “thegeorgeofjudges” for their compassionate supports and collaborations during this period.

I extend my appreciation to the brothers and sisters of the Student Christians’ Organization (SCO), University of the Western Cape Branch, Cape Town, South Africa for their prayers and love.

I thank the Lagos State University (LASU), Ojo Lagos, Nigeria for given me the opportunity to study outside Nigeria.

I will like to thank the family of Mr and Dr (Mrs) Morounke Saibu for their prayers, encouragements, and supports both in Nigeria and South Africa.

My special thanks go to my families for their financial support, prayers, and phone calls - Mrs E.O Ogundiji, Mr and Mrs Samuel Abidoje, chief Michael Ajiboye and chief Mrs Victoria Ajiboye (in-law), Mr and Mrs Odunola Awolowo, Mrs Kehinde Odeniyi, Mr and Mrs Gboyega Abidoje, Engineer and Mrs Omowumi Momoh, Mrs Atinuke Ogundipe, Mr and Mrs Kayode Ogundiji, Mr and Mrs Joke Moradeyo, and Mr and Mrs Kunle Abidoje.

I extend my appreciation to my fathers in the Lord for their prayers, calls, and supports to my family when I was away. They are Rev. and Mrs John Akanbi, Rev. and Mrs Nathaniel Oyewole, Rev. and Mrs J. O Akanbi, Rev. and Mrs M.O Amusan, and Bishop (Dr) and Mrs Olugbenga Olusoga (aka Baba God).

My special gratitude goes to my wife for her support throughout this period. She is a wonderful and dependable wife. I love you so much.

Finally, my heartfelt thanks go to my wonderful children – Oluwatosin Abidoje, Olumide Abidoje, and Oluwaferanmi Abidoje for their prayers and greetings at all time.

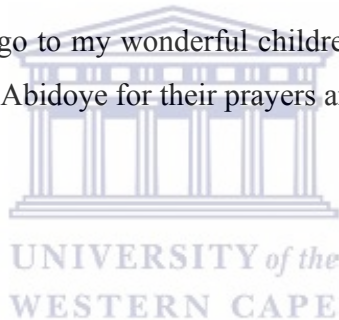



## List of Publications

A.P. Abidoeye, H.O. Nyongesa and A.O. Tiamiyu “Energy Aware Routing Algorithm And Asynchronous Sleep-Wake Scheduling Protocol” South African Institute of Electrical Engineers (SAIEE) (under review)

**Ademola P. Abidoeye**, N.A. Azeez, A.O. Adesina and K.K. Agbele “A Novel Routing Algorithm for Energy Optimization in Wireless Sensor Networks”, *Research Journal of Information Technology*, New York, USA, Vol. 4. No. 4, 2012, pp.186-194

**A. P. Abidoeye**, N. A. Azeez, A. O. Adesina, K. K. Agbele, “ANCAEE: A Novel Clustering Algorithm for Energy Efficiency in Wireless Sensor Networks”, *Journal of Wireless Sensor Networks*, Vol. 3, No. 9, Sept. 2011, pp. 307-312

N.A. Azeez, **A. P. Abidoeye**, K. K Agbele, A. O Adesina “A Dependable Model for attaining maximum authentication security procedure in a Grid Based Environment” *Trends in Applied Sciences Research*”, New York, USA, Vol. 7, No.1, 2012, pp.78-86

**A.P Abidoeye**, N.A. Azeez, A.O. Adesina and K.K Agbele “UDCA: Energy Optimization in Wireless Sensor Networks Using Uniform Distributed Clustering Algorithms”. *Research Journal of Information Technology*, Vol. 3 No. 3, 2011, pp. 191-200

**A.P. Abidoeye**, N. A. Azeez, A. O Adesina, K. K Agbele, H. O. Nyongesa. “Using Wearable Sensors for Remote Healthcare Monitoring System”. *Journal of Sensor Tech.*, Vol.1, No.2, June,2011, pp. 22-28

UNIVERSITY of the  
WESTERN CAPE

## Table of Contents

|       |  |    |
|-------|--|----|
| 1     | Introduction.....  | 1  |
| 1.1   | Background to the Research.....  | 1  |
| 1.2   | Motivation.....  | 4  |
| 1.3   | Research Aims.....   | 5  |
| 1.4   | Constraints of Wireless Sensor Networks.....   | 6  |
| 1.5   | Research Objectives.....   | 7  |
| 1.6   | Research Methodology.....  | 7  |
| 1.7   | Contributions to knowledge.....  | 8  |
| 1.8   | Thesis Outline.....  | 8  |
| 2     | Literature Review.....   | 10 |
| 2.1   | Introduction.....  | 10 |
| 2.2   | The Unique Characteristics of Wireless Sensor Networks.....                            | 10 |
| 2.3   | Challenges of Wireless Sensor Networks.....  | 11 |
| 2.4   | Applications of Wireless Sensor Networks.....  | 13 |
| 2.4.1 | Environmental and Agriculture Monitoring.....  | 13 |
| 2.4.2 | Military Applications.....   | 13 |
| 2.4.3 | Home Applications.....   | 14 |
| 2.4.4 | Healthcare Applications.....   | 14 |
| 2.5   | The Architecture of a Sensor Node.....   | 15 |
| 2.5.1 | Structure of a Sensor Node.....  | 15 |
| 2.6   | Architecture of Sensor Network.....  | 18 |
| 2.6.1 | Flat Architecture.....   | 20 |
| 2.6.2 | Hierarchical Architecture.....   | 20 |
| 2.7   | Classification of Wireless Sensor Networks.....  | 21 |
| 2.8   | Routing Protocols for Wireless Sensor Networks.....                                    | 22 |
| 2.8.1 | Challenges of Routing Protocols.....   | 23 |
| 2.9   | Classification of energy efficient routing protocols for wireless sensor networks..... | 24 |
| 2.9.1 | Routing Protocols Path Establishment.....  | 26 |
| 2.9.2 | Structures of Network Protocols.....   | 27 |

|        |   |    |
|--------|---|----|
| 2.9.3  | Layer based Protocols.....  | 30 |
| 2.10   | Medium Access Control Protocols for Wireless Sensor Networks.....   | 33 |
| 2.11   | Techniques for Energy Optimization in Wireless Sensor Networks..... | 36 |
| 2.11.1 | Cross Layer Design Technique for Energy Optimization in WSNs.....   | 37 |
| 2.11.2 | Sleep Mode Transceiver Technique.....                               | 43 |
| 2.11.3 | Hierarchical Routing Technique.....                                 | 46 |
| 2.12   | Method of Data Aggregation.....                                     | 50 |
| 2.13   | Heterogeneous Sensor Networks.....                                  | 53 |
| 2.14   | Computational Intelligence.....                                     | 55 |
| 2.14.1 | Swarm Intelligence.....   | 56 |
| 2.14.2 | Metaheuristics.....   | 57 |
| 2.14.3 | Particle Swarm Optimization.....                                    | 58 |
| 2.14.4 | Ant Colony Optimization Scheme.....                                 | 62 |
| 2.15   | Simulation Techniques.....  | 64 |
| 2.16   | Chapter summary.....  | 67 |
| 3      | Energy Models for Wireless Sensor Networks.....                     | 68 |
| 3.1    | Traditional Energy Model.....                                       | 68 |
| 3.2    | Service-aware Energy Model.....                                     | 69 |
| 3.2.1  | Network model.....  | 70 |
| 3.2.2  | Energy model.....   | 71 |
| 3.2.3  | Network lifetime.....   | 72 |
| 3.3    | Sensor-aware Energy Model.....                                      | 73 |
| 3.3.1  | Network model.....  | 73 |
| 3.3.2  | Energy model.....   | 74 |
| 3.3.3  | Network lifetime.....   | 75 |
| 3.4    | Load-balancing Energy Model.....                                    | 76 |
| 3.4.1  | Network model.....  | 76 |
| 3.4.2  | Energy model.....   | 77 |
| 3.4.3  | Network lifetime.....   | 80 |
| 3.5    | Chapter summary.....  | 81 |
| 4      | Energy Optimization using Clustering Techniques.....                | 82 |

|       |  |     |
|-------|--|-----|
| 4.1   | Introduction .....   | 82  |
| 4.2   | Distance-aware Clustering.....                                 | 85  |
| 4.3   | Selection of Cluster heads Phase .....                         | 86  |
| 4.3.1 | Cluster heads Selection Process .....                          | 86  |
| 4.4   | Service-aware Clustering.....                                  | 92  |
| 4.4.1 | The Service-aware Clustering Problem .....                     | 94  |
| 4.5   | Formation of Clusters Phase.....                               | 96  |
| 4.6   | Data Transmission phase .....                                  | 98  |
| 4.6.1 | Asynchronous sleep-wake scheduling scheme .....                | 99  |
| 4.6.2 | Data Aggregation for Sensor Nodes .....                        | 102 |
| 4.7   | Determining the Optimal Number of Clusters .....               | 105 |
| 4.8   | Topology Analysis.....   | 108 |
| 4.8.1 | Uniform Distribution of Sensor Nodes .....                     | 108 |
| 4.8.2 | Random Distribution of Sensor Nodes .....                      | 109 |
| 4.9   | Maximizing the Sensor Network's Lifetime .....                 | 110 |
| 4.10  | Chapter Summary .....  | 114 |
| 5     | Multipath Routing protocol using Ant Colony Optimization ..... | 115 |
| 5.1   | Introduction .....   | 115 |
| 5.1.1 | Ant Colony Optimization.....                                   | 116 |
| 5.1.2 | Contribution and Outline.....                                  | 118 |
| 5.2   | The Multipath Routing Model.....                               | 119 |
| 5.2.1 | The Routing Problem.....                                       | 119 |
| 5.2.2 | The Routing Solution.....                                      | 121 |
| 5.3   | The MRACO Algorithm.....                                       | 123 |
| 5.3.1 | Algorithm Illustration.....                                    | 124 |
| 5.3.2 | Local Pheromone Update.....                                    | 125 |
| 5.3.3 | Pheromone Control .....  | 126 |
| 5.4   | Chapter summary.....   | 128 |
| 6     | Performance evaluation of the proposed protocol .....          | 129 |
| 6.1   | Metrics used in the simulation.....                            | 130 |
| 6.2   | Comparing cluster-based and tree topology .....                | 132 |

|        |  |     |
|--------|--|-----|
| 6.3    | Effect of sensor nodes and distance of cluster heads from the base station ..... | 143 |
| 6.4    | Significance of free space energy model .....                                    | 144 |
| 6.5    | Energy consumption per round.....  | 146 |
| 6.6    | Energy consumption in normal sensor network and hybrid nodes network.....        | 151 |
| 6.7    | Performance comparison of three different models .....                           | 153 |
| 6.8    | Energy dissipation varying the number of cluster heads .....                     | 163 |
| 6.9    | Performance evaluation of service-aware energy model.....                        | 169 |
| 6.10   | Performance evaluation of the load-balancing energy model .....                  | 176 |
| 6.11   | Performance Analysis of Ant Colony Optimization Algorithm.....                   | 179 |
| 6.11.1 | Distribution of dissipated energy of sensor nodes .....                          | 179 |
| 6.12   | Chapter Summary .....  | 183 |
| 7      | Contributions and Future work .....  | 184 |
| 7.1    | Summary of contributions .....   | 185 |
| 7.2    | Recommendations and Future work .....  | 188 |
|        | References .....   | 189 |
|        | Appendix A: Flowchart for the multi-path routing ant colony optimization.....    | 201 |
|        | Appendix B: Flowchart for the EOCIT routing protocol .....                       | 202 |

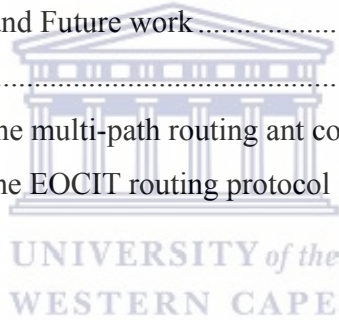

## LIST OF FIGURES

| Number  | Page |
|---|------|
| Figure 1.1: Structure of a sensor node (Sendra et al., 2011).....                         | 2    |
| Figure 1.2: Architecture of wireless sensor networks (Labrador and Wightman, 2009).....   | 2    |
| Figure 2.1: Structure of a sensor node (Sendra et al., 2011).....                         | 16   |
| Figure 2.2: Block diagram of a typical sensor node .....                                  | 16   |
| Figure 2.3: Wireless sensor networks .....  | 19   |
| Figure 2.4: Single-hop network architecture .....   | 19   |
| Figure 2.5: Multi-hop clustering architecture .....                                       | 21   |
| Figure 2.6: Routing protocol in WSNs .....  | 24   |
| Figure 2.7: Directed diffusion.....   | 28   |
| Figure 2.8: LEACH network model .....   | 31   |
| Figure 2.9: Periodic listen and sleep in S-MAC .....                                      | 35   |
| Figure 2.10: OSI model layers and sensor networks protocol stack.....                     | 39   |
| Figure 2.11: Two-layer hierarchical cluster-based architecture .....                      | 47   |
| Figure 2.12: Direct data transmission Scheme .....  | 48   |
| Figure 2.13: Clustering technique for wireless sensor networks .....                      | 49   |
| Figure 2.14: Power consumption model.....   | 50   |
| Figure 2.15: Data Aggregation using Beamforming algorithm.....                            | 51   |
| Figure 2.16: Computational intelligence paradigms.....                                    | 56   |
| Figure 2.17: Particle Swarm (Population =12) in a 2-dimensional space .....               | 59   |
| Figure 2.18: Particle swarm organization schematic diagram (R.-M. Chen, 2011) .....       | 60   |
| Figure 2.19: Ants find the shorter path.....  | 63   |
| Figure 3.1: Radio energy model (Heinzelman et al., 2002).....                             | 68   |
| Figure 3.2: Multi-hop data routing in concentric circles of wireless sensor network ..... | 77   |
| Figure 4.1: Hierarchical clustering of a sensor network (Karl and Willig, 2007) .....     | 82   |
| Figure 4.2: Hierarchical routing architecture.....  | 84   |
| Figure 4.3 : Temporary cluster formation.....   | 89   |
| Figure 4.4: EOCIT dynamic cluster formation process.....                                  | 91   |
| Figure 4.5: Sensor nodes clustering based on service differentiation.....                 | 95   |
| Figure 4.6: Flowchart for EOCIT hierarchical cluster formation.....                       | 97   |

|   |     |
|---|-----|
| Figure 4.7: Operation of sensor node transmission .....                                       | 99  |
| Figure 4.8: State transition diagram of a sensor node.....                                    | 100 |
| Figure 4.9: The operating cycle in clustering methods (Heinzelman et al., 2002).....          | 101 |
| Figure 4.10: Different modes of a sensor node in wireless sensor networks.....                | 102 |
| Figure 4.11: Energy dissipation to perform local data aggregation and.....                    | 105 |
| Figure 4.12: Network layout of uniform sensor nodes distribution.....                         | 109 |
| Figure 4.13: Random deployment of sensor nodes.....   | 110 |
| Figure 4.14: Flow conservation condition .....  | 114 |
| Figure 5.1: Backbone sensor network adapted from (Karl and Willig, 2007).....                 | 115 |
| Figure 5.2: Ants exploitation between the food sources (F) and Nest (S).....                  | 117 |
| Figure 5.3: Mapping routing parameters into ACO transition probability .....                  | 122 |
| Figure 5.4: Multi-path routing ant colony optimization for WSNs .....                         | 123 |
| Figure 5.5: Pheromone evaporation.....  | 127 |
| Figure 6.1: T-Test for the significant difference between EOCIT and clustering protocols..... | 138 |
| Figure 6.2: Total energy consumed vs number of clusters, $V=100$ .....                        | 142 |
| Figure 6.3: Total energy consumed vs number of clusters, $V=500$ .....                        | 142 |
| Figure 6.4: Optimal number of clusters vs number of sensor nodes .....                        | 143 |
| Figure 6.5: Average energy consumption vs number of clusters for EOCIT protocol.....          | 144 |
| Figure 6.6: Effect of $\alpha$ and $\beta$ values on network lifetime .....                   | 145 |
| Figure 6.7: Number of sensor nodes alive varying in $\alpha$ value.....                       | 146 |
| Figure 6.8: Energy consumption per round vs number of clusters .....                          | 147 |
| Figure 6.9: Distance from CHs to the base station vs optimal No. of clusters.....             | 148 |
| Figure 6.10: Average energy dissipation vs no. of clusters for DECSA energy model ....        | 148 |
| Figure 6.11: Average energy dissipation vs no. of clusters for MOCRN energy model....         | 149 |
| Figure 6.12: Average energy dissipation vs no. of clusters for proposed energy model....      | 149 |
| Figure 6.13: Effect of network area on sensor network's lifetime .....                        | 151 |
| Figure 6.14: Comparison of energy dissipation of SN and HSN.....                              | 152 |
| Figure 6.15: Live nodes vs time(s) when base station is at the center of the network area     | 155 |
| Figure 6.16: Live nodes vs time(s) when base station is outside the network area .....        | 155 |
| Figure 6.17: LND when the base station is located at the center of the network. ....          | 156 |
| Figure 6.18: LND when the base station is located outside the network area .....              | 156 |
| Figure 6.19: Energy dissipation in WSNs using EOCIT and EOCIT-HSN algorithms .....            | 158 |
| Figure 6.20: Sensor nodes lifetime with 80 sensor nodes and 20 Hybrid nodes .....             | 160 |

|   |     |
|---|-----|
| Figure 6.21: Sensor nodes lifetime with 400 sensor nodes and 100 Hybrid nodes .....                     | 160 |
| Figure 6.22: Network lifetime varying the network size from 100 nodes to 500 nodes ....                 | 161 |
| Figure 6.23: Comparison of the number of alive nodes in the three models .....                          | 161 |
| Figure 6.24: Number of nodes alive in normal and hybrid nodes .....                                     | 162 |
| Figure 6.25: Residual energy of EOCIT-HSN and EOCIT-MIX .....   | 163 |
| Figure 6.26: Energy dissipation of HSN vary the number of cluster heads .....                           | 164 |
| Figure 6.27: Average network Lifetime when base station is located at the center of the network .....   | 166 |
| Figure 6.28: Average network lifetime when base station located at outside the network area .....       | 166 |
| Figure 6.29: Number of nodes vs end-to-end delay .....  | 167 |
| Figure 6.30: Number of nodes vs throughput .....  | 168 |
| Figure 6.31: Packet delivery ratio vs number of nodes .....   | 169 |
| Figure 6.32: Expected number of rounds vs no. of clusters when varying values of $\alpha$ and $M$ ..... | 170 |
| Figure 6.33: Number of alive nodes vs time(s) when $p=0.04$ and $h=3$ .....                             | 172 |
| Figure 6.34: Number of alive nodes vs time(s) when $p=0.1$ and $h=5$ .....                              | 173 |
| Figure 6.35: Number of rounds until first nodes dies vs Fraction of the advanced nodes $p$ .....        | 173 |
| Figure 6.36: Number of rounds until first nodes die varying the value of $h$ .....                      | 174 |
| Figure 6.37: Number of rounds until 10% nodes die varying the value of $p$ .....                        | 175 |
| Figure 6.38: Network stable period .....  | 175 |
| Figure 6.39: Number of rounds until 10% nodes die varying the value of $h$ .....                        | 176 |
| Figure 6.40: Network stable period .....  | 176 |
| Figure 6.41: The effect of sensor nodes $V$ on the optimal value of radius $r_1$ .....                  | 177 |
| Figure 6.42: The effect of network radius $R$ on the optimal value of radius $r_1$ .....                | 178 |
| Figure 6.43: The Effect of cluster heads $K$ on the optimal value of radius $r_1$ .....                 | 178 |
| Figure 6.44: Distribution of dissipated energy vs number of nodes .....                                 | 180 |
| Figure 6.45: Average transmission delay vs time .....   | 181 |
| Figure 6.46: Energy consumption vs number of sensor nodes .....   | 182 |
| Figure 6.47: Network lifetime vs number of nodes .....  | 183 |



## List of Tables

| Number   | Page |
|--|------|
| Table 4.1: Uniqueness of the proposed protocol .....   | 83   |
| Table 4.2: Mapping sensor nodes service delivery into routing roles .....                                      | 93   |
| Table 4.3: Area covered by each node and total required number of sensor nodes .....                           | 108  |
| Table 5.1: Number of shortest paths from source nodes to a base station.....                                   | 124  |
| Table 6.1: Parameters used in the simulations.....   | 131  |
| Table 6.2: Energy consumption of sensor nodes using clustering method.....                                     | 133  |
| Table 6.3: Energy consumption of Sensor Nodes using Direct Transmission Method .....                           | 134  |
| Table 6.4: Summary of the energy consumption by EOCIT and LDD protocols .....                                  | 137  |
| Table 6.5: The 2-tailed independent samples test.....  | 139  |
| Table 6.6: Optimal number of clusters for different protocols .....  | 141  |
| Table 6.7: Shapes of sensor network for $\epsilon fs = 10\text{pJ/bit/m}^2$ , $M=100$ (Zhang et al., 2009).150 |      |
| Table 6.8: Network lifetime for different heterogeneous protocols for $p=0.04$ and $h=3$ ...                   | 171  |
| Table 6.9: Network lifetime for different heterogeneous protocols for $p=0.1$ and $h=5$ .....                  | 172  |
| Table 7.1: Summary of Research Contributions.....  | 188  |

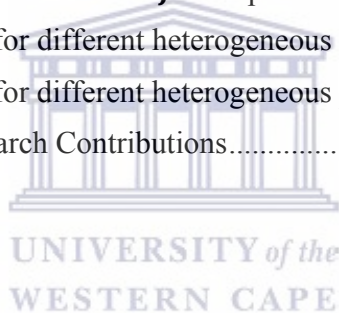

# Chapter 1

## 1 Introduction

### 1.1 Background to the Research

Rapid developments in wireless communications, micro electro-mechanical systems, and digital electronics have enabled the design of tiny, cheap, low-cost sensor nodes (Murthy et al., 2012). A sensor node is a device equipped with sensing components capable of measuring changes in an environment, processing, and transmitting sensed data over a short distance through a wireless medium (Abidoeye et al., 2011). However, a complex task can be achieved through the coordinated efforts of sensor nodes forming a wireless sensor network to cooperatively monitor large physical environments (Akyildiz and Vuran, 2010). A wireless sensor network (WSN) is composed of hundreds or thousands of sensor nodes which can be randomly or uniformly distributed in a target area. A typical sensor node has four main components as shown in Figure 1.1: (a) sensing unit, (b) processing unit with small memory, (c) communication unit, (d) Power source (Elshakankiri et al., 2008).

The sensing component in a node measures physical characteristics like humidity, or soil moisture from the surrounding areas in which it is placed and changes them into electric signals. The processing unit collects and processes sensed data captured from its surroundings. A small memory is attached with the microprocessor which stores processed data temporarily before it is forwarded to the communication unit. Moreover, a communication unit contains radio transceivers with a short communication range for data transmission and reception over a wireless medium. A power source consists of small batteries for supplying power to drive all the other components of the sensor node. WSNs are usually deployed to monitor either static or dynamic events in a particular area. The measurement of static events such as temperature, humidity, and pressure are very easy to conduct. On the other hand, dynamic events are difficult to monitor, because the target objects in most cases are constantly moving up or down. For instance, they have been used for monitoring the movement of whales in the ocean and wild animals in the forests. The general architecture of wireless sensor networks is shown in Figure 1.2.

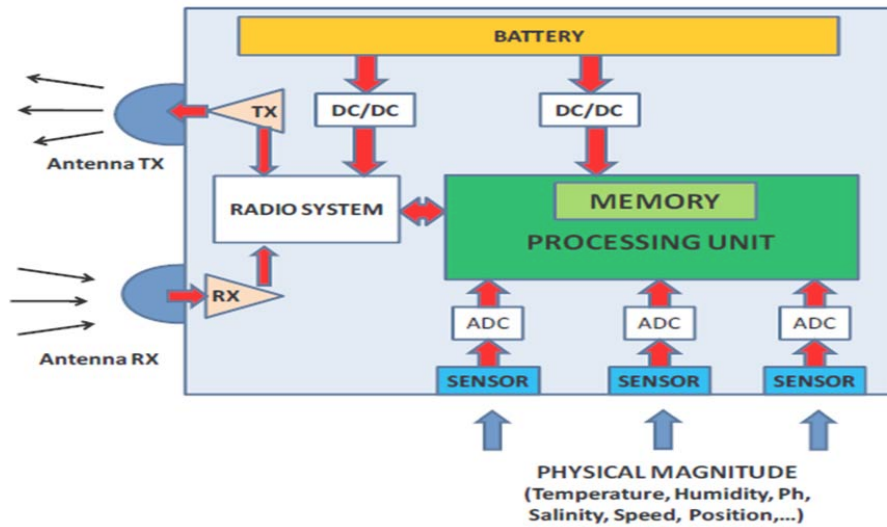

Figure 1.1: Structure of a sensor node (Sendra et al., 2011)

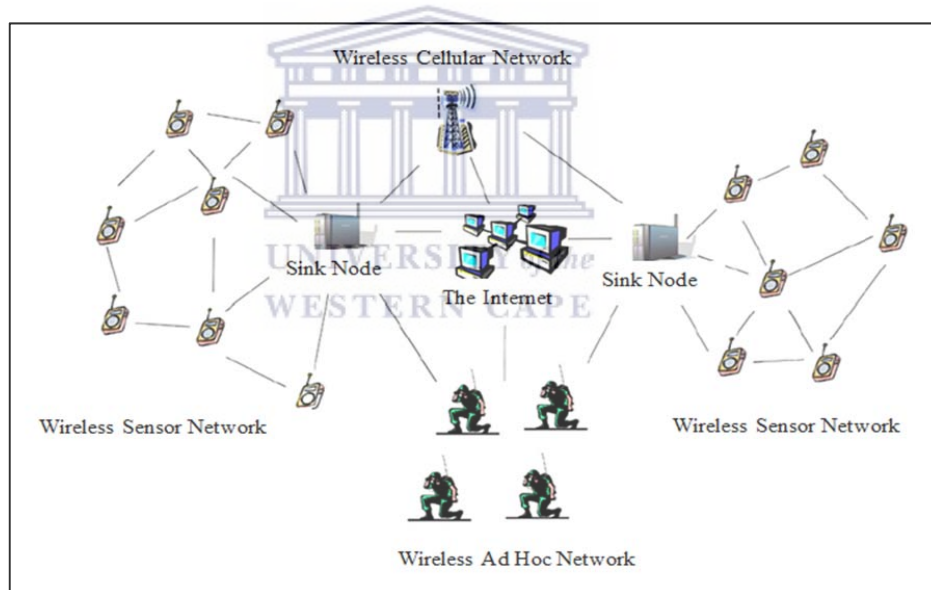

Figure 1.2: Architecture of wireless sensor networks (Labrador and Wightman, 2009)

Sensor nodes are powered by small batteries run on low power which make up a network of sensors useful in monitoring different applications where electricity is not available. The cost of deployment of WSNs to jointly monitor a particular area of interest is minimal, unlike traditional wired networks. Instead of deploying long lengths of wires routed

through a protective conduit on the wall, users simply need to place nodes randomly in the target area without the need for any pre-existing infrastructures (D. Yang et al., 2012).

Wireless sensors have significant advantages over traditional wired sensors. They can be deployed in difficult environments, particularly those areas in which the deployment of wired networks is infeasible.

WSNs have a wide range of applications; these include the monitoring of industrial machines, military applications for military command, human imaging and tracking. Other areas include environmental monitoring and control, home automation, and building security (Buratti et al., 2009; Dietrich et al., 2010). In recent years, applications of WSNs have been extended to healthcare monitoring. Medical doctors can now monitor their patients' physiological data remotely, store the data and use it for medical exploration (Akyildiz and Vuran, 2010). In a similar manner, sensor nodes are used for home automation - sensor nodes and actuators are inserted into home appliances such as electric bulbs, refrigerators, micro-wave ovens and so on. This makes it possible for end users to control these devices remotely. Changes in air condition, water level, and soil moisture can also be monitored using sensor nodes. As the internet has revolutionized our lives by allowing a large number of users to exchange various forms of information, in the near future, it is envisioned that WSNs will be embedded virtually in all devices used for our today-to-day activities to transform the way we work, live and interact with our physical environments (Baqer and Kamal, 2009).

Furthermore, wireless communication is a main technology for the efficient operation of a WSN which has been widely used for traditional wireless networks and where significant achievements have been made. On the physical layer of the protocol stack, a variety of modulation, antenna, and synchronization methods have been developed for different types of networks and application requirements. Efficient communication protocols at higher layers of the protocol stack address different networking issues such as routing, medium access control, network security and quality of service. These communication protocols and techniques provide a good background for the development of wireless communication in WSNs (Huang et al., 2010). Currently, most traditional wireless networks such as cellular systems, wireless personal area networks (WPANs), mobile ad hoc networks (MANETs), and wireless local area networks (WLANs) use radio frequency (RF) for

communication ranging from micro wave to millimeter wave. The RF provides Omni-directional links and does not need a line of sight but this cannot be used for sensor networks. In addition, most communication protocols designed for traditional wireless networks do not consider the unique features of WSNs, the limited energy in particular. Therefore, they cannot be used for WSNs directly without modification.

In order for the WSNs to be widely deployed for a longer period largely depends on the availability of low power, software platforms and cheap hardware for sensor networks. Rapid development in wireless communications has resulted in the cost and physical size of a sensor node being significantly reduced. In addition, one of the design objectives of WSN is to minimize energy consumption; this can be achieved in both the hardware and software designs. Considering the hardware platform, various hardware designs have been used to achieve low-power consumption in sensor networks these include a low-power circuit which has enabled the development of ultralow power hardware components such as microcontrollers and microprocessors. Power consumption can be further minimized using the dynamic power management (DPM) technique (W Dargie and C Poellabauer, 2010). This technique enables sensor nodes to be in a low power state or to use shutdown idle components when not transmitting or receiving any data. Dynamic voltage and frequency scaling (DVFS) (Le Sueur and Heiser, 2010), is another technique that has been used for energy efficiency where the frequency and voltage of links are dynamically adjusted to minimize power consumption.

Furthermore, energy consumption can be minimized on the software platform if energy awareness is integrated into the architecture of the system software such as the operating system and network protocols. The operating system is responsible for task scheduling, memory allocation, and networking. Software platforms for sensor networks include nesC, Contiki, TinyOS, and TinyGALS Operating Systems (Heidemann et al., 2012).

## **1.2 Motivation**

Driven by the ever increasing application of wireless sensor networks in many areas, has resulted in them becoming a popular area of research in recent years. Low cost of deployment, easy to monitor, and able to control physical environments remotely have been the added advantages that make them applicable in many areas (Syed and Partha,

2008). For a large WSN to be deployed for a long period in a target area, the nodes must have low power consumption and low operating cost. However, to keep the cost down, typical sensor nodes are small in size with limited energy and computation power, and are included with small batteries which they use as the main source of power that can only provide limited power. Although, energy scavenging and other passive energy gathering techniques are able to provide extra energy to the nodes, they can only provide a moderate amount of operating power.

In spite of the innumerable applications of sensor networks, they are faced with many challenges. These include small memory, a limited processor power, scalability, short communication range, security, and limited energy source (Gungor et al., 2010b). The small memory and limited processor power in sensor networks will disappear very soon with the current improvement in digital electronics. However, the limited power source available to the nodes is unlikely to be solved soon due to an increase in the functionalities of sensor nodes.

Sensor networks in most cases are deployed in remote areas, in an open field, hostile environments, or unreachable areas where it may be difficult or even impossible to replenish the batteries when they are run out of energy (Sohraby et al., 2007). It is expected that the sensor nodes will remain in operation for years before replacing the batteries. Therefore, it is imperative to extend the battery life of each sensor node through energy optimization so that the network will remain functional for a longer period.

### **1.3 Research Aims**

Wireless Sensor Networks (WSNs) are currently an active research area primarily because of their wide range of applications. However, the operation of a large scale WSNs still requires solutions to the many challenges of sensor networks such as limited hardware resources, limited energy, being prone to failure and a short transmission range. Among these challenges, limited energy is the most critical challenge of wireless sensor nodes, since it involves not only minimizing the energy dissipation of a single sensor node, but also maximizing the lifetime of an entire network.

The central aim of this work is to minimize sensor nodes' energy consumption in WSNs by optimizing the distance between the nodes and the data center, called the based station. To

accomplish this aim, we propose three energy models and design algorithms that will partition the sensor networks into clusters.

There are various techniques in the literature that have been proposed to minimize energy consumption in WSNs that are not based on the hardware platform.

Some of these techniques include exploiting spatio-temporal correlation, cross layer, ant colony optimization, and hierarchical routing (D. Kumar et al., 2011; Vuran and Akyildiz, 2010; Y. Wang et al., 2009).

These approaches are discussed in detail in chapter 2. Additional and new techniques are needed to address the energy constraint in wireless sensor networks.

However, in addition to clustering approach used in this research, ant colony optimization (ACO) approach is used for multipath routing to efficiently transmit data between the source nodes and the base station.

#### **1.4 Constraints of Wireless Sensor Networks**

Some of the wireless sensor nodes constraints are discussed below.

##### ***Low Individual Energy Consumption***

Sensor nodes dissipate large amount of energy during communications and can use up their limited energy if every node is allowed to communicate directly to the data centre (base station). In a multi-hop WSNs, sensor nodes play a dual role as data collector and data forwarder. Malfunctioning of some nodes due to power failure can cause significant topological changes. This might require that packets reroute and reorganize the nodes in the network. Therefore, it is essential to minimize sensor nodes energy consumption in WSNs (Yahya and Ben-Othman, 2009).

##### ***Low Communication and Computation Overhead***

A typical sensor node is very small and composed of tiny components with limited bandwidth. This calls for simple protocols that require minimal processing and a small storage unit. The extra communication and computation introduced by the energy optimization schemes must also be kept low. If not, the energy needed to perform the optimization schemes may be much more than the benefits (Chiang, 2008).

### ***Balanced Energy Usage***

Minimizing the energy consumption of every sensor node is vital, the energy status of the whole network should also be of the same order. If some sensor nodes have more data to transmit than other nodes, those nodes will use up the limited energy quickly and greatly affect the lifetime of the entire network. The work load of sensor nodes should be distributed evenly in the network to prolong the network lifetime.

### ***Uncertainty in Measured Parameters***

This constraint is due to sensor node malfunction, sensing/transmitting incorrect data, and desired sensed data becoming mingled with noise and node placement.

## **1.5 Research Objectives**

The objectives of this research are:

1. To derive network energy models for a wireless sensor network
2. To design and develop energy efficient algorithms which minimize energy consumption of wireless sensor networks.
3. To simulate and validate the developed models and algorithms using MATLAB.
4. Implement a proof-of-concept scenario for energy optimization within WSNs.

## **1.6 Research Methodology**

An important component in the design of optimization algorithms is to have a good understanding of the factors that affect the WSNs for which the algorithms are proposed.

To accomplish the objectives of the intended algorithms mentioned above, the following methods will be used.

1. A thorough literature review of existing routing protocols that have been proposed for energy optimization in wireless sensor networks will be carried out;
2. Derivation of mathematical models, implementation of optimization algorithms and communication protocols;
3. Review of computational intelligence optimization techniques;
4. The proposed algorithms and protocols will be simulated using a suitable simulator for wireless sensor networks.



## **1.7 Contributions to knowledge**

Wireless sensor networks (WSNs) have become an interesting area of research in recent years due to their different application areas. Energy consumption is a major challenge in WSNs and this constraint coupled with the deployment of a large number of sensor nodes have added many challenges to the design and management of WSNs (Sendra et al., 2011).

The contributions of this thesis are: we propose three energy models for wireless sensor network: a) service-aware energy model b) sensor-aware energy model and c) load-balancing energy model. In addition, we present two novel approaches for clustering the nodes of a hierarchical sensor network: a) a distance-aware clustering where nodes are clustered based on their distance and the residual energy and b) a service-aware clustering where the nodes of a sensor network are clustered according to their service offered to the network and their residual energy. These approaches are implemented into a family of routing protocols referred to as EOCIT (Energy Optimization using Clustering Techniques) which combines sensor node energy location and service awareness to achieve good network performance. Finally, building upon the Ant Colony Optimization System (ACS), Multipath Routing protocol based on Ant Colony Optimization approach for Wireless Sensor Networks (MRACO) is proposed as a novel multipath routing protocol that finds energy efficient routing paths for sensor readings dissemination from the cluster heads to the sink/base station of a hierarchical sensor network.

## **1.8 Thesis Outline**

The remaining parts of the thesis are organized as follows. In chapter 2, the literature related to this research is reviewed. The unique characteristics, challenges and different application areas of WSNs, are discussed. The sensor nodes architecture, classifications, and communication protocols of WSNs are also studied. Various routing protocols for WSNs and techniques for energy optimization in WSNs are discussed. The strengths and weaknesses of each protocol are highlighted. The chapter explains different computational intelligence techniques. However, we lay emphasis on the Ant Colony Optimization (ACO) technique as one of the methods used for this research.

Chapter 3 describes various energy models used for the implementation of this research. The conventional radio energy model used for wireless sensor networks is briefly discussed. Thereafter, three proposed energy models are presented. The proposed models are the service-aware energy model, the sensor-aware energy model and the Load-balancing energy model.

Chapter 4 presents a comprehensive overview of the research design and methodology. Detail of the proposed protocol architecture, algorithms designed, topology analysis, and multi-path routing protocol are discussed. Different equations are formulated in this chapter in order to achieve the stated objectives.

Chapter 5 this chapter presents the main building blocks of a new multipath routing protocol called multipath routing using ant colony optimization (MRACO). Model for the multipath routing is designed. The chapter introduces pheromone control to discourage continuous data transmission through the optimal path and encourages search of new paths that were previously non-optimal through evaporation.

In Chapter 6, the results obtained from the performance of the EOCIT algorithms are compared with selected protocols, followed by discussions on the results obtained.

Finally, Chapter 7 presents the contributions and recommendations for the future research.

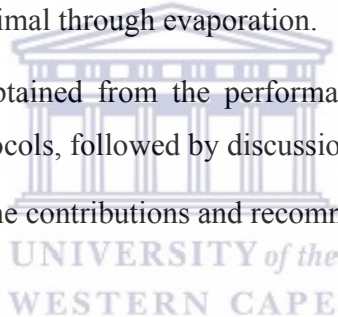

## Chapter 2

### 2 Literature Review

#### 2.1 Introduction

Wireless Sensor Networks (WSNs) are one of the most important and newest technologies for the 21st century. Recent advances in wireless communication technologies, microelectronic mechanical systems (MEMs), and increase in demand for wireless devices, have led to the design of cheap, and tiny sensor nodes that can be used to measure changes in the area of interest. These sensor nodes have the ability to sense, perform pre-processing on the sensed data and transmit it to the next nodes or to the base station for further processing (W Dargie and C Poellabauer, 2010). The nodes interconnect with one another through wireless links to perform distributed sensing tasks. The sensor networks, in-conjunction with the help of the internet, provide more opportunities for both the military and civilians for many applications.

WSNs have unique characteristics that distinguish them from convectional wireless communication networks such as cellular systems and the mobile ad hoc network (MANET). These unique features are discussed in the next section.

#### 2.2 The Unique Characteristics of Wireless Sensor Networks

Many algorithms and communication protocols have been proposed for traditional wireless ad-hoc networks (Tümer and Gündüz, 2010). However, these protocols are not suitable for WSNs because of their unique characteristics. Some of the unique features of sensor nodes are:

- (1) *Small size*: The physical size and small memory in a sensor node limits many of the abilities of nodes in terms of communication capability and processing abilities.
- (2) *Self-Organize*: Sensor nodes can be randomly or uniformly distributed in an area of interest without any pre-existing infrastructure. Once they are deployed, they can organize themselves into a communication networks.

- (3) *No global identification:* Sensor nodes are usually deployed in large number, in the hundreds. It is not possible to include global addressing (i.e IP address) to uniquely identify each node in the network due to their small physical size.
- (4) *Constant topology change:* Sensor networks frequently change when new nodes are added to the networks to increase the network size or some nodes are removed from the networks when they have used up their energy, become damaged or channel fading occurs.
- (5) *Prone to attack:* Sensor nodes deployed in hostile or dangerous environments operate without monitoring. They are prone to physical attack or damage.
- (6) *Data redundancy:* Sensor nodes are densely deployed in large numbers in most applications. They collaborate among themselves to achieve a common task. Nodes close to each other can sense similar data. Thus, data sensed by sensor nodes close to each other usually have a certain level of similarity.
- (7) *Application specific:* Sensor networks are ad hoc networks which can be distributed in close proximity in a particular area for a specific application. Network requirements change with its application. The unique characteristics of wireless sensors present new challenges in the design of wireless sensor networks.

### **2.3 Challenges of Wireless Sensor Networks**

The main design objective of wireless sensor networks (WSNs) is to measure changes in the target area and transmit sensed data for a long time. This design is affected by many challenging factors due to the unique features of the sensor nodes. These challenges must be overcome in order to prolong the lifetime of sensor networks. This section presents some of the challenges of sensor networks.

*Limited power availability:* Sensor nodes are powered with small batteries which must be either recharged using solar energy or replaced when the batteries run out of power. For wireless sensor nodes, neither option is suitable which implies they will simply be discarded once their energy source is exhausted. This constraint presents many new challenges in the development of hardware and software, also in the design of network architectures and protocols for sensor networks. To extend the operational lifetime of a

sensor network, energy efficiency should be considered in every aspect of sensor network design, including software, hardware, protocols, and network architectures.

*Fault tolerance:* Fault tolerance is the ability to sustain sensor network functionalities without any interruption due to sensor node failures (Goyal and Tripathy, 2012). Sensor nodes are usually deployed in large numbers depending on the application area. We expect that failures in wireless sensor nodes will be much higher than the wired networks due to their limited energy source and secondly they are more prone to physical damage than wired networks. Moreover, sensor nodes must be able to configure themselves, collaborate and operate with other nodes, adapt to failures and changes in the environmental stimuli without human intervention. Therefore, protocols designed for a sensor network should be efficient enough to take care of the failures of some sensor nodes while maintaining the overall functionality of the network. This is particularly applicable to the routing protocol design, which has to ensure that other paths are available for data transmission.

*Production costs:* Sensor networks consist of hundreds to thousands of nodes, the cost of a single sensor node is directly proportional to the total cost of the sensor networks. In order for the cost of a WSN to be justified, the total cost of a network should not be more expensive than deploying a single traditional sensor device. Thus, the target price of a single sensor node has to be cheap and less than \$1 for sensor networks to be practically feasible. Presently the prices for sensor devices are much higher than the price of a Bluetooth (Akyildiz and Vuran, 2010; Philipp and Glesner, 2011).

*Scalability:* Sensor networks are usually deployed in large numbers in a target area. This results in the sensing of related data and improves the fault tolerance of the network. In order to solve the scalability challenge, the networking architectures and protocols designed for these sensor networks should be able to scale to these large numbers of sensor nodes efficiently and the network density depends on the area of application (Anastasi et al., 2009).

*Transmission media:* Sensor nodes normally communicate with each other using license-free radio bands, Industrial Scientific and Medical (ISM) bands. However, some sensor networks use infrared or optical communication, with the former having the advantage of being robust and virtually interference free.

## 2.4 Applications of Wireless Sensor Networks

The demand for the use of wireless sensor networks (WSNs) has increased considerably in recent years given their flexibility in solving problems in various application areas such as environmental monitoring, military applications, healthcare, seismic and so on. They have driven the growth of sensor networks in recent years particularly due to the new era of Internet-of-Things (IoT). They have been successfully used in environments where conventional wired networks cannot be deployed. For example sensor nodes can be used to monitor wild animals inside forests, in deep sea or other hazardous places. They are used to detect and/or monitor different ambient conditions such as sound, humidity, temperature, light, soil composition, pressure and so on (Baronti et al., 2007). Some of the areas where WSNs have been successfully applied are discussed below.

### 2.4.1 Environmental and Agriculture Monitoring

Wireless sensor networks have been used to monitor different types of objects and/or changes in the environment. These areas include

- *Precision agriculture.* Livestock, crops management, and control of fertilizer concentration in the soil are possible with sensor networks. In addition, animals' movement in a forest can be tracked by randomly deploying sensor nodes in the forest area (Akyildiz and Vuran, 2010).
- *Disaster detection.* Large number of wireless sensors can be deployed in the target area to detect non-natural or natural disasters. For instance, floods or forest fire can be detected on time with the help of sensor nodes deployed in the area.

### 2.4.2 Military Applications

Sensor networks are self-organized, fault tolerant, and easy deployment make them a promising technique for military applications. They are applied in the following ways.

- *Equipment monitoring.* Leaders of military troops can monitor military equipment and ammunitions, location of troops, and supplies to improve military communications, control, command, and computing. They can also be used in the reconnaissance of

opposing forces, and for biological, chemical, and nuclear (BCN) attack detection (Zheng, 2009).

- *Protection.* Sensitive objects or places such as military sub-stations, communication towers, military headquarters, and atomic plants can be protected from enemy' attack by deploying sensor nodes to monitor the areas where these objects are sited.

### 2.4.3 Home Applications

- *Home intelligence.* Advances in modern technologies have enabled sensor nodes to be integrated into home appliances such as micro-wave ovens, electric bulbs, smart refrigerators, and vacuum cleaners. Moreover, if the nodes are connected to the external networks such as internet, home users can control their home appliances remotely which is more convenient, cost effective, and creates intelligent living environments for human beings.
- *Remote metering.* Reading of utility meters can now be remotely taken in homes using wireless sensors for electricity, water, or gas, and then forward the readings wirelessly to a data center for further processing.

### 2.4.4 Healthcare Applications

- *Medical sensing.* Applications of WSNs have been recently extended to healthcare. They have been used to monitor both at home and mobile patients for health care purposes. They can be used to track and monitor the movement of medical personnel inside the hospital, monitor the current health status of patients, and administer drugs to patients remotely. They can be implanted or attached to a patient's body, collect vital signs from his/her body and send the vital signs to the specialist doctor at an urban centre via internet for analysis and to make necessary recommendations (Akyildiz and Vuran, 2010).
- *Micro-surgery.* A group of microelectronic-mechanical systems based robots may cooperate to perform microscopic and minimally invasive surgery.

## **2.5 The Architecture of a Sensor Node**

Wireless sensor networks (WSNs) are collections of dispersed sensor nodes in a particular area of interest with the aim of measuring or sensing useful data. They perform simple logic for signal processing, topology management and data transmission handling. Sensor nodes that combine sensing of physical parameters such as light, temperature, or pressure with multimedia such as video and image sensors capabilities are expected to become ubiquitous in the future (Nefzi and Song, 2012).

A sensor node measures physical parameters: the chemical or biological properties of its environment, and then processes and converts the measured data into electrical signals. Actuators are included in many sensor nodes which allow them to communicate with the outside world. An actuator accepts electrical signals and converts the electrical signals into a physical phenomenon to be acted upon by the user(s). For instance, an actuator can be a valve controlling a motor that automatically opens or closes a window or door of a building, the flow of hot water or a pump that controls the amount of fuel injected into an engine. Actuators and sensors belong to the same family of transducers which take commands from the processing device (controller) and transform these commands into input signals for the actuator, which then interacts with a physical process, thereby forming a closed control loop (W Dargie and C Poellabauer, 2010).

### **2.5.1 Structure of a Sensor Node**

A sensor node consists of four main units as shown in Figure 2.1. They are the sensing unit, processing unit, communicating unit, and power unit. A typical sensor node diagram is shown in Figure 2.2.



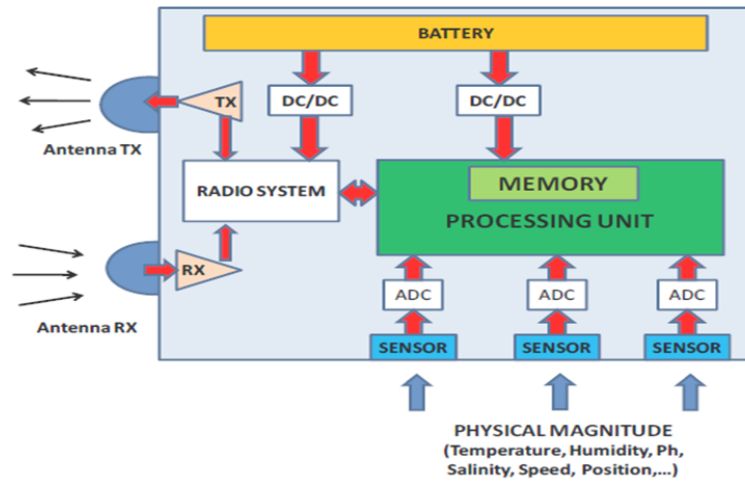

Figure 2.1: Structure of a sensor node (Sendra et al., 2011)

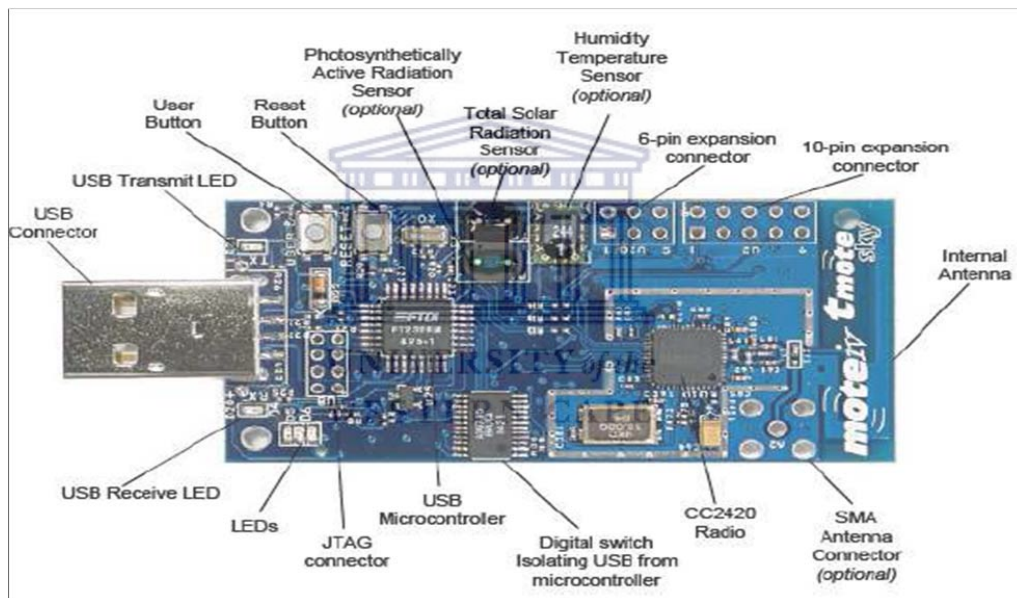

Figure 2.2: Block diagram of a typical sensor node

*Sensing unit* consists of two subunits: Sensors, analog and digital converters (ADCs). Sensor nodes can be categorized into three types as explain below.

*Passive, Omni-directional sensors:* They measure physical quantity using the sensor node point without actually manipulating the environment by active probing. They obtain their energy from the environment which makes them self-powered and used to amplify their analog signals (Han et al., 2012). Examples of these sensors include light sensors, smoke detectors, thermometers, chemical sensors, and air pressure.

*Narrow-beam sensors:* These sensors are also passive, but the direction of measurement is well defined. A good example of this type of sensors is a camera which can “take measurement” in a given direction, but has to be rotated before taken the measurement.

*Active sensor:* It is a detective device that requires input energy from a source other than that which is being sensed. It generates electric current directly in response to environmental stimulation. Examples of active sensors are piezo-electric accelerometers and thermocouples. Thermocouples produce voltage related to a temperature of two metals and if the two junctions are at different temperatures, electricity is generated.

However, the analog signals produced by the sensors based on the observed phenomenon are converted to digital signals by the ADCs and then sent to the processing unit (Gajjar, 2009).

*Processing unit:* It consists of a microcontroller integrated with small storage. The microcontroller is the core of a wireless sensor node. It controls the sensor, executes the communication protocols and signals processing algorithms on the received data and transmits only the useful data to the base station for further processing. A microcontroller is designed in such a way that it supports different operating modes, it can be in *Active*, *Idle* or *Sleep* mode for power management. Each node is designed to consume different amount of energy. For instance, Strong ARM microcontroller consumes about 50mW of power in *Idle* mode and about 0.46mW while in *Sleep* mode. Energy consumed by the microcontroller depends on two important factors: operating voltage and operating frequency.

However, it has been shown that energy consumed during communication to transmit a unit bit of data over a distance of 100m is approximately the same energy consumed to process 3000 instructions (Pantazis and Vergados, 2007). Therefore, it is necessary for the nodes to perform data processing such that less data are transmitted during communication.

*Communication unit:* This unit contains a radio transceiver whose functionality is to maintain continuous communication between the nodes and the outside world. Power consumption characteristics of a radio in sensor nodes are affected by different factors including the type of modulation used; transmission power, data rate, and operational duty cycle. The limited energy available to a node imposes a limit on the

transmission range of a radio. In order for sensor nodes to communicate with the least possible power, they need to be located within the transmission range of each other (Ba et al., 2013). Moreover, a considerable amount of energy can be saved if the radio transceiver is turned off rather than being in idle mode when not communicating. A similar amount of energy is consumed when the radio's operating mode switches from sleep mode to active mode (Potdar et al., 2009).

*Power unit:* This unit holds small batteries that supply power to other sensor node components. The batteries play an important role in determining sensor node lifetime. The power consumption of a battery needs to be constantly monitored because if the amount of current drawn from the battery is more than the rated current capacity (specified by the manufacturer) over a long time, this significantly leads to a reduction in battery's lifetime.

Battery lifetime can be increased in two possible ways

- Minimizing the energy dissipation through a data processing technique.
- Turning off the radio transceiver when not transmitting or receiving any data.

## **2.6 Architecture of Sensor Network**

A wireless sensor network (WSN) is composed of a large number of sensor nodes deployed in a particular area of interest and the sensed data are transmitted to a base station. A base station is a data center that collects all sensed data from sensor nodes. It can be located inside the sensing region or outside the sensor network area. In addition to being a data collector, it also serves as a gateway to outside communication e.g the internet as shown in Figure 2.3.

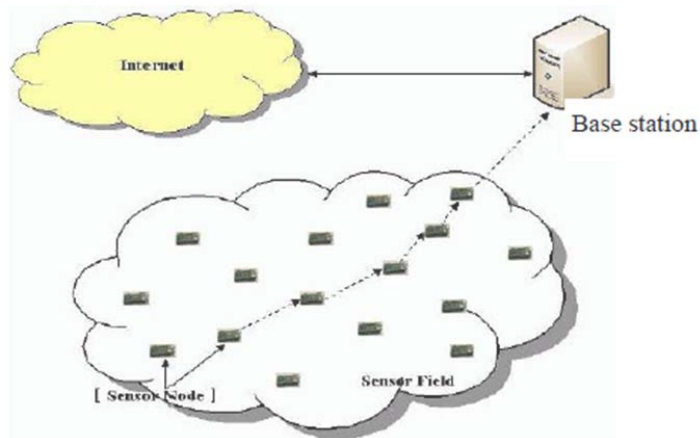

Figure 2.3: Wireless sensor networks

Sensed data can be transmitted to the base station either through single-hop or multi-hop transmissions.

*Single-hop communication:* In a single hop, sensor nodes communicate directly either to the group leaders or the base station without intermediate nodes as shown in Figure 2.4. It involves long distance transmission and a lot of energy is consumed through this process, particularly for a large network. The architecture of the single-hop method could vary depending on the network topology. It is imperative to reduce the transmission distance and amount of traffic generated during transmission in order to conserve sensor node energy consumption.

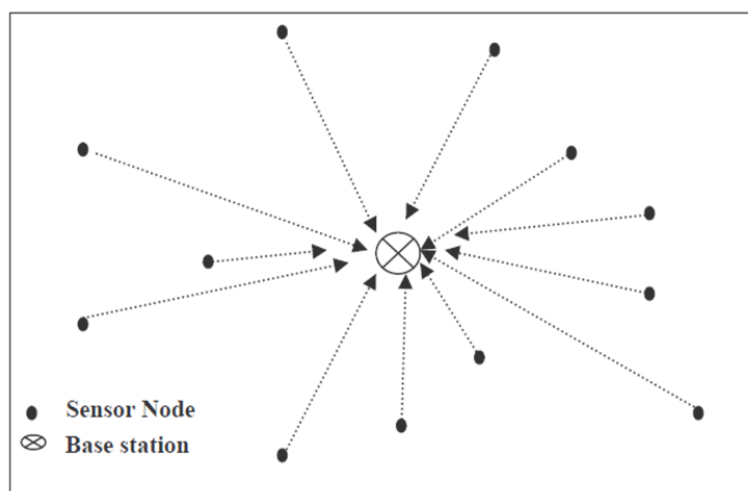

Figure 2.4: Single-hop network architecture

*Multi-hop communication:* In multi-hop communication, sensed data are transmitted to either a cluster head node or a base station through the intermediate nodes, reducing the communication distance between the sensor nodes. One of the earliest work to use this technique is in the Minimum Transmission Energy (MTE) protocol (Heinzelman et al., 2002). The authors proposed that a packet with a transmission distance more than  $2\beta^{-\frac{1}{2}}$  should be transmitted through the intermediate nodes, where  $\beta$  is the density of the neighbouring nodes. Multi-hop architecture can be grouped into two designs: Flat and Hierarchical Architectures.

### **2.6.1 Flat Architecture**

In a flat network, all nodes are homogeneous, each node plays the same role in sensing and transmitting data (D. Kumar et al., 2009). Nodes are paired with each other and deployed in a large number. It is not always feasible to assign a global address to uniquely identify each node in a network unlike wireless cellular networks. In light of this, data gathering in sensor node is usually through data-centric routing, where the sink sends a query to all nodes in the network via flooding, requesting specific data. Only nodes that have the requested data will respond to the sink's query through a single hop or multi-hop communication.

### **2.6.2 Hierarchical Architecture**

Sensor nodes are organized into different groups in layers called a hierarchical clustering network. In each cluster, a node or more are selected as cluster heads based on the protocol used and the size of the network. They collect sensed data from member nodes which perform pre-processing and forward the processed data to the base station via multi-hop communication as shown in Figure 2.5. Using this method, the volume of data transmitted by the cluster heads to the sink is reduced. Member nodes only need to transmit their data to their cluster heads over a short distance. Sensor nodes energy consumption is minimized using this method (Heikalabad et al., 2010).

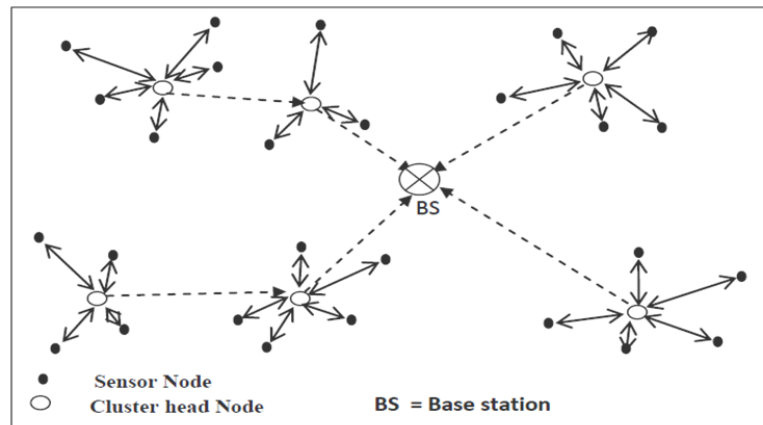

Figure 2.5: Multi-hop clustering architecture

## 2.7 Classification of Wireless Sensor Networks

Wireless sensor networks (WNSs) are application specific; they are deployed in a target area for specific application. They can be classified into different networks as follows.

*Static and mobile networks:* A sensor network can be either static or mobile. In a static network, all sensor nodes remain in a fixed position (Zheng, 2009). It is common in many sensor networks applications such as environmental monitoring. However, some sensor nodes need to be mobile to accomplish a particular task, for example, wireless biomedical sensors attached to the patient's body to collect vital signs (Jones et al., 2008). A static sensor network is easier to implement and easier to control unlike a mobile sensor in which the mobility effect has to be considered.

*Single-sink and multi-sink networks:* The number of sink(s) in a sensor network can be a single or multiple sinks.

*Single sink network:* In a single sink network, there is only one sink located in the sensing region or outside the network area. All sensor nodes within the network send their sensed data to the sink either through a single-hop or multi-hop depending on the number of the nodes in the network.

*Multi-sink network:* In a multi-sink, there are two or more sinks located inside the sensing region or outside the network area. Data are sent to the nearest sink to balance the traffic load and improve the hotspot effect in the network (Z. Wang et al., 2012).

*Deterministic and nondeterministic networks:* Sensor node deployment can be either deterministic or nondeterministic. In a deterministic sensor network, sensor node positions are pre-planned and are fixed once deployed. For instance, they can be positioned in a specific place inside the hospital to monitor the movement of medical staff and how patients are responding to treatments. On the other hand, nondeterministic sensor networks are randomly deployed into a target area without any pre-planning. Nodes deployed in hostile or unreachable environments are usually non-deterministic.

*Homogeneous network:* A homogeneous sensor network is a network consisting of sensor nodes that are identical in terms of sensing range, processing, battery energy, storage, and hardware complexity. In a homogeneous network, cluster heads are selected among the eligible nodes to receive sensed data from their member nodes and fuse them before they are sent to the base station reducing the volume of data transmitted.

*Heterogeneous network:* In a heterogeneous network, some nodes have higher capabilities in terms of energy level, processing power, storage, sensing range and communication than other nodes (D. Kumar et al., 2011). Nodes with higher capabilities in terms of energy are given the responsibility to collect sensed data from other nodes. They process the data and forward the processed data to the base station.

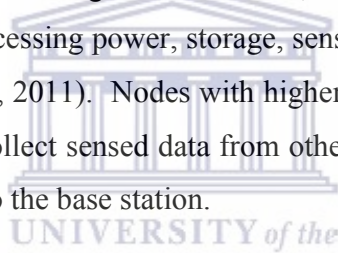

## **2.8 Routing Protocols for Wireless Sensor Networks**

Routing is a process of transmitting data along a path between a source node and destination node. Data routing in wireless sensor networks (WSNs) is generally implemented at the network layer of the protocol stacks (Zheng, 2009). The traditional routing protocols designed for mobile ad hoc networks cannot be used for WSNs directly due to their unique nature. Sensor nodes can organize themselves into autonomous wireless ad hoc networks once deployed in a target area with little or no maintenance. They collaborate among themselves to carry out specific tasks of the application for which they are deployed. Routing protocols are in charge of creating and maintaining routes between the nodes. The different ways in which routing protocols operate make them suitable for many applications. However, they are faced with many challenges. The section below discusses some of the challenges of routing protocols.

### **2.8.1 Challenges of Routing Protocols**

The primary objective of setting up sensor networks is to sense data in the area of interest and report to the base station for further analysis. Good routing algorithms assist in achieving this aim by determining appropriate paths along which data will be routed. While considering this basic requirement, the following factors should be considered in designing good routing algorithms.

#### ***Dynamics Networks***

Sensor networks are composed of three main components: sensor nodes, sink, and events being monitored. In most sensor networks, sensor nodes are stationary except in a few application areas that utilize mobile sensor (Akyildiz and Vuran, 2010; Chinnappen-Rimer and Hancke, 2012). It is deemed necessary to support the mobility of sinks or gateways. Routing messages from or to mobile nodes is more challenging since router stability becomes an important optimization factor in addition to bandwidth and energy.

#### ***Available Energy***

During network set-up, the process of setting up an energy efficient route is generally influenced by the energy available to each node. The transmission power of a sensor radio is proportional to the square of distance and higher in the presence of obstacles. Direct routing will perform very well in terms of energy consumption if the distance between the nodes and the base station are very close to each other, are less than set threshold distance value or the base station is located at the centre of the network. However, if the distance between the nodes and the base station is more than maximum transmission range of sensor node, multi-hop routing will perform better (consume less energy) than direct data transmission.

#### ***Data Delivery Models***

In sensor networks, data delivery to the sink can be event-driven, query-driven, continuous or hybrid (Tilak et al., 2002). In event-driven and query-driven models, the transmission of data is triggered when an event occurs or a query is generated by the sink. In the continuous delivery model, data is sent periodically by each node to the sink. The data



delivery model has a strong influence on the routing protocols especially with regard to route stability and energy consumption minimization.

### *Data Fusion*

Sensor nodes sense and transmit different data in a network; there is a high probability that sensor nodes which are close to each other, sense similar data. These data can be fused together by using functions such as min, average, max and suppression (eliminating duplicates) so that the number of data transmitted would be reduced. These functions can be performed in each sensor node either partially or fully by performing in-networking data reduction (Preprocessing) (Tan et al., 2012). Substantial energy can be saved through data fusion (Sobral et al., 2013). This method has been used to achieve traffic optimization and energy efficiency in a number of routing protocols (Iyengar and Brooks, 2012).

## **2.9 Classification of energy efficient routing protocols for wireless sensor networks**

Routing protocols for wireless sensor networks (WSNs) can be classified into four types according to the way routing paths are established including: path establishment, network structure, protocol operation, and communications initiator as shown in Figure 2.6.

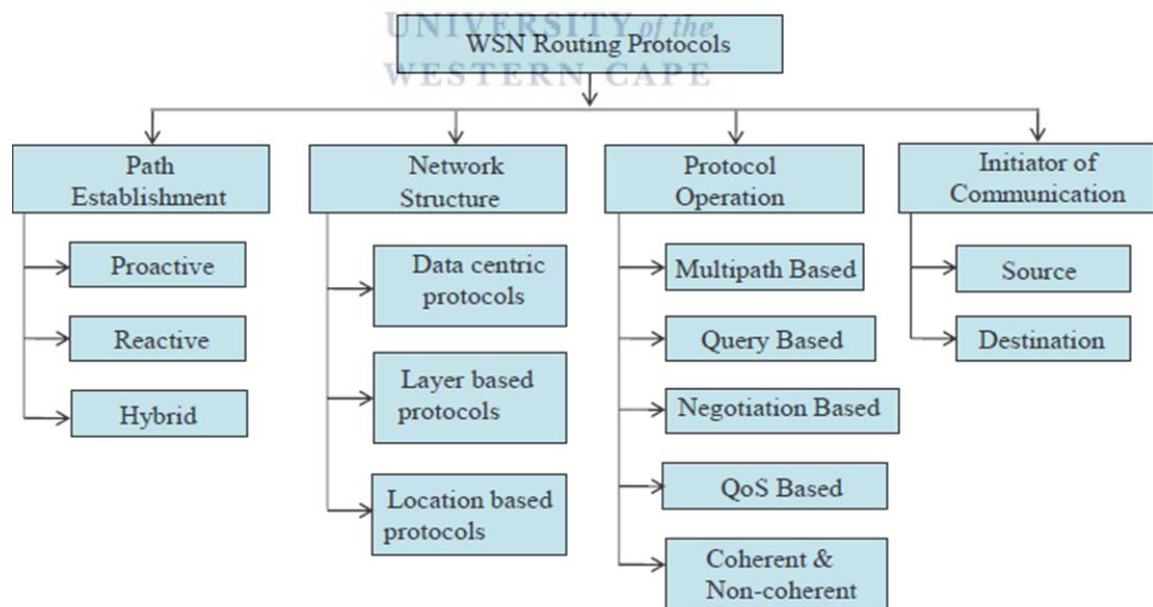

Figure 2.6: Routing protocol in WSNs

### *Flooding Technique*

Flooding is a mechanism for transmitting data to all sensor nodes in a network. It is a simple technique frequently used for path discovery and to transmit data in sensor networks without using a complex route discovery algorithm and costly network topology maintenance (Zheng, 2009). Flooding uses a reactive approach whereby each sensor node receives data and broadcasts the data which are repeatedly retransmitted until the data get to the final destination or the maximum number of hops for the data has been reached. Moreover, data transmitted follow the new routes as the network topology changes. Flooding is very easy to implement and ensures that all transmitted data reach their destination. However, it has several shortcomings. Firstly, it is susceptible to traffic implosion in which duplicate messages are sent to the same sensor node.

Secondly, it is resource blindness, consuming a large amount of energy without any consideration for the limited energy available to sensor nodes.

Finally, its method of data transmission in most cases results in overlapping which occurs when two sensor nodes sense the same region and send similar data to the same neighbour.

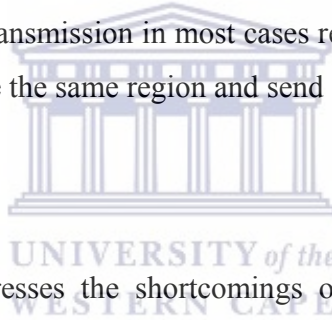

### *Gossiping Technique*

The gossiping method addresses the shortcomings of flooding. Although gossiping is related to flooding; it uses a simple forwarding method and does not necessitate a complex route of discovery algorithms or network topology maintenance (García Villalba et al., 2009). Contrary to flooding, each sensor node that uses gossiping routing sends sensed data to randomly selected neighbours. Upon receiving the data, the neighbour node also randomly selects the next neighbour and transmits the received data. The process continues until the data reaches to the destination or the maximum hop count is exceeded. A traffic implosion problem is avoided when using the gossiping method by reducing the number of data that each sensor node transmits to the neighbour node. However, gossiping takes more time to transmit data especially in large networks due to the random nature of the protocol which uses only one path at a time.

### 2.9.1 Routing Protocols Path Establishment

Routing algorithms for ad hoc networks can be grouped based on the data received by the sensor nodes which are used to compute optimal paths during communication. They are proactive, reactive, and hybrid protocols (X. Liu, 2012).

*Proactive routing protocols:* This is also known as table driven. The protocols establish paths before they are actually required. Each node in the network stores the routing information on the routing table in its memory (*tabu*) in order to maintain consistent and accurate data transmission. The information is used to transmit data periodically to the base station. The main advantage of this technique is that routes are available whenever they are required and there is no delay in searching for new routes, unlike on-demand routing protocols. The shortcomings are the overheads incurred in building and maintaining potentially very large routing tables and old information in these tables may lead to routing errors.

*Reactive routing protocols:* Reactive routing protocols are also known as on-demand routing protocols. These protocols do not discover and maintain global information across all nodes on the networks. The protocols only rely on a dynamic route search to establish paths between a source and a destination. A source node knows the address or identity of the destination node (base station), and starts a route discovery within the sensor network. The process is completed when at least one route is discovered or when all possible routes have been established. An example of on-demand protocol is the Dynamic Source Routing protocol (DSR) (Amri et al., 2010).

*Hybrid routing protocol (HRP):* HRP is a network routing protocol that combines the advantages of both reactive and proactive routing to determine optimal paths towards destination and report network topology data modifications. EIGRP (Enhanced Interior Gateway Routing Protocol) is an example of hybrid routing protocol (Chadha, 2013).

## 2.9.2 Structures of Network Protocols

The structure of a network is very important and plays significant role in the operation of the routing protocols in WSNs. It can be classified into three categories namely: Data Centric Protocols, Layer based protocols and Location based protocols.

### *Data Centric Protocols*

Data Centric protocols transmit data from a source node to a destination node through the relay nodes. The relay nodes perform data fusion on the received data and send it to the next neighbour nodes. The process continues until the data reach the base station. Examples of directed diffusion are described below.

*Directed Diffusion:* This protocol is application-aware, and was proposed by (C Intanagonwiwat et al., 2000b). The main objective of this protocol is to achieve considerable energy saving to prolong the lifetime of sensor networks. To achieve this objective, directed diffusion fuses together all incoming data from different source nodes, by removing redundancy, and thus minimizing the number of data transmitted to the destination node. It finds paths from multiple sources to a single destination that allows in-network consolidation of redundant data. The main elements of directed diffusion include data messages, interests, gradients and reinforcements. Events (data) sensed by sensor nodes are stored temporarily in their memories, and base station requests for data from member nodes by broadcasting interests. An interest message is a query that describes what a user wants from member nodes for a named data. Interest (requested data) diffuses through the network; each node broadcasts the message to its neighbour. For instance, a sink may query for a data by sending interest and the neighbouring nodes propagate the interest hop-by-hop to other nodes in the network. Each time a node receives an interest message, it checks whether the interest exists in its memory or not. If it is a new interest, the node sets up a gradient which specifies an attribute value and direction to draw data that satisfies the query forwarded by the sink. Each subsequent sensor that receives the interest sets up a gradient towards the nodes from which the interest was received. This process continues until gradients are set-up from the source nodes to the sink. Neighbouring nodes may have different gradient strength resulting in a different amount of information flow.

Data transmission in directed diffusion involves three stages (a) sending interest (b) gradient set-up (c) data delivery as shown in Figure 2.7.

Sensor nodes set-up gradients with multiple paths, the shortest paths are selected for data transmission. Data is aggregated on the way as it is moving towards the destination to reduce communication cost. The sink intermittently refreshes and re-transmits the interest when it begins to receive data from sensed nodes. The reason is that interests are not reliably transmitted throughout the network. Sensor nodes using directed diffusion achieve energy savings by choosing an optimal path, caching, and processing data within the network. However, the performance of data aggregation techniques used in the directed diffusion is affected by many factors such as the number of source nodes, the communication network topology, and the positions of the source nodes in the network.

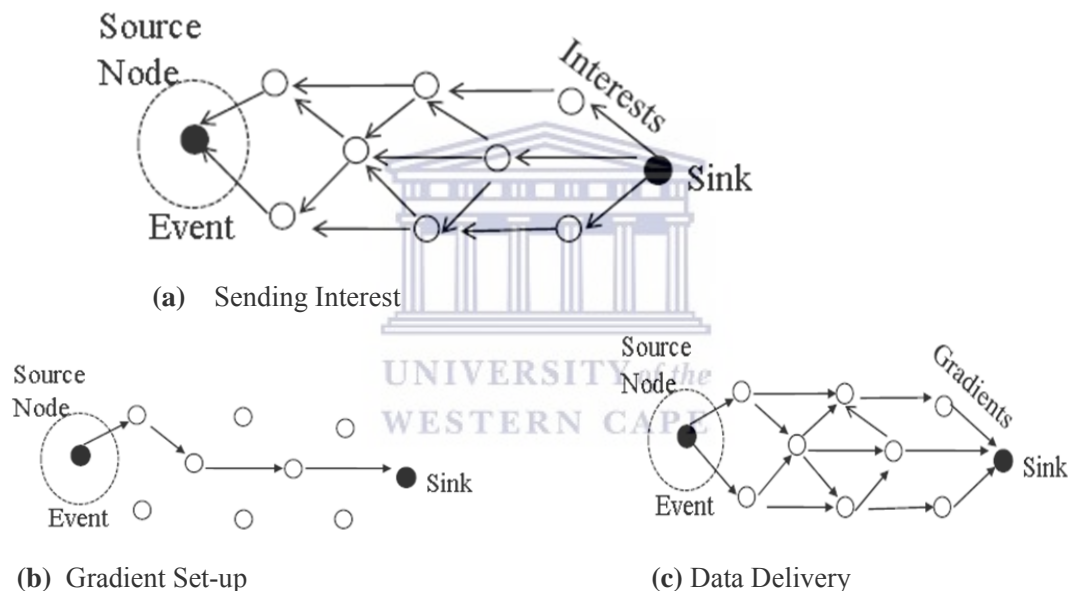

Figure 2.7: Directed diffusion

*Energy Aware Directed Diffusion*: Energy aware directed diffusion (EADD) proposed by (J. Choe and Kim, 2008) is an improvement on directed diffusion. It depends on an individual sensor node's available energy to change the forwarding movement. It allows sensor nodes with more residual energy to respond promptly rather than the nodes with less residual energy. Whenever a sensor node receives a token for path establishment to transmit data, the node will not respond immediately to forward the data. Instead, only the nodes with more residual energy will respond and transmit data to the next node. The

process continues until the data get to the final destination (base station). EADD is energy efficient in the sense that transmission of duplicate data is minimized. It balances nodes energy utilization to prolong the network lifetime. However, this protocol uses single hop for data transmission, it may not be energy efficient for a large network.

### **Minimizing Transmission Energy in Sensor Networks via Trajectory Control**

This protocol is an example of energy aware directed diffusion; the protocol considered transmission energy optimization in WSNs where data are sent directly to a base station without intermediate nodes. The base station chooses the optimal path that minimizes the total transmitted energy at the sensor subject to a maximum travel delay constraint. (Ciullo et al., 2010). Communication radii are assigned to sensor nodes based on their load. Short transmission ranges are for sensor nodes with a heavy load and long transmission ranges are for nodes with a light load. The algorithm calculates the sensor node radii based on the average arrival rate to the sensors. This approach is energy efficient provided the number of sensor nodes is small (i.e less than hundreds of nodes). It has low overhead since the processes for the selection of cluster heads and formation of clusters are absent.

However, data are transmitted based on radii, and it may be difficult to determine the best set of sensor nodes radii that reduce the transmission energy consumption. The scalability problem is another challenge; the method of communication is many-to-one. This results in huge data traffic for a large network. Finally, the approach puts a limit between the sensor nodes and the data base station on how far away they can be from each other in order to communicate.

*Load balance directed diffusion:* This protocol is simply called LDD, and is a non-clustering protocol proposed by (Lai et al., 2011). It is an improvement over directed diffusion protocol (Chalermek Intanagonwiwat et al., 2003). Data are transmitted directly from source nodes to the base station without intermediate nodes. It takes the hop count and available power into consideration in determining the gradients. This protocol uses the current gradient information and automatically changes to another path when the residual power of the sensor node on the original path approaches reference energy value (threshold).

The advantage of this protocol is that it has low overhead because the processes involved in the selection of cluster heads and formation of clusters are avoided. However, the short coming of this protocol is that it is not energy efficient, especially when the size of the network is becoming large, that is when the number of sensor nodes increases from tens to hundreds of nodes.

### **2.9.3 Layer based Protocols**

Conventional routing and data transmission protocols for WSNs may not be optimal in terms of energy consumption (Das and Ammari, 2009). To overcome the shortcomings of this transitional routing, an energy efficient communication protocol can be used by the sensor nodes to transmit their sensed data to the sink. This can be achieved by grouping sensor nodes into different groups called clusters. Each cluster is managed by one or more cluster heads (CHs) depending on the number of sensor nodes in the network. A CH is responsible for coordinating the data transmission activities of all sensor nodes in its cluster. Nodes in each cluster communicate with their cluster heads that act as a local base station which in turn send the aggregated data to the main base station. This process reduces the transmission distance between the sensor nodes and the CHs compared with flat routing.

Hierarchical routing is a layered based protocol, originally proposed for wired networks (Heikalabad et al., 2010). Its concept is used to efficiently maintain energy consumption of sensor nodes by allowing each node to transmit its data within a cluster via single hop or multi-hop. The CH receives data from member nodes in its cluster; and performs data fusion to reduce the number of transmitted data to the base station.

*Low-Energy Adaptive Clustering Hierarchy* (LEACH) proposed by (Heinzelman et al., 2002) is an example of hierarchical routing protocols. Moreover, LEACH protocol is one of the first hierarchical routing techniques proposed for WSNs. Most other protocols proposed thereafter for hierarchical routing were using LEACH protocol as a benchmark (Abbasi and Younis, 2007).

LEACH is a routing protocol designed to aggregate and deliver data to the sink.

The main objectives of LEACH are

- To reduce energy consumption of each sensor node in the network;
- To extend sensor network lifetime and
- To reduce the number of communication messages through the use of data aggregation.

To achieve these objectives, LEACH operation is divided into rounds. Each round consists of a setup phase and a steady state phase. During the setup phase, the network is organized into a set of clusters and some nodes are randomly selected as cluster heads (CHs) based on probability. Each CH periodically collects data from member nodes in its cluster. It aggregates the data collected and then transmits the aggregated data to the base station. The network model for LEACH is shown in Figure 2.8.

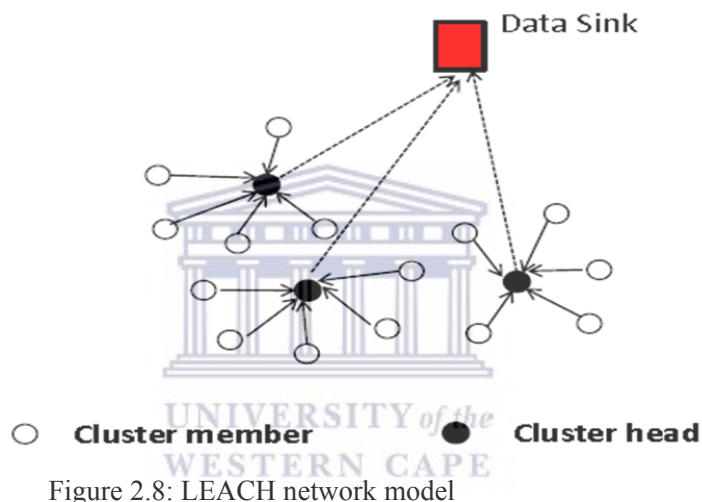

Figure 2.8: LEACH network model

In order to balance energy consumption among the nodes and to prevent sudden death of a node when it runs out of energy, cluster heads change randomly after a given round. To determine if it is the turn of a node to become a CH, a node  $v$  randomly generates a random number  $k$  between 0 and 1. The value of  $k$  is compared with the CH threshold  $T(n)$  value. Node  $v$  becomes CH if the value of  $k$  generated is less than  $T(n)$ . The threshold for the selection of CH is designed in such a way that only a predetermined fraction of nodes,  $P$ , is selected as CHs in each round. The threshold ensures that nodes that have been CHs in the last  $\frac{1}{P}$  rounds are not elected as CHs in the current round.

The threshold  $T(n)$  for nodes  $V$  is expressed as follows



$$T(n) = \frac{P}{1 - p * (r \bmod \frac{1}{p})} \quad \text{if } n \in G$$

where the variables

$V$  is the number of the sensor node such that  $N = \{v_1, v_2, \dots, v_V\}$ ;

$P$  is the desired percentage of cluster heads;

$G$  represents the set of nodes that have not been selected as CHs in the last  $\frac{1}{p}$  rounds;

$r$  is the current round;

$T(n)$  is the threshold value.

This model ensures that if a node has been chosen as a CH in the last  $\frac{1}{p}$  rounds, it will not be selected in the current round. LEACH achieves reduction in energy consumption compared with previous proposed models such as direct communication protocol and minimum energy routing protocols. Sensor nodes in LEACH die randomly and its dynamic clustering prolongs network lifetime. Its data transmission is through single hop from node to the cluster head. However, this protocol has several shortcomings.

Firstly, nodes selected as cluster heads in LEACH are not evenly distributed within the network. When this happens, sensor nodes that are far from the cluster head will transmit through long distance and more energy will be consumed during the transmission. Secondly, CHs selection method is based on probability which may lead to an increase in overhead in selecting new cluster heads and results in an increase in energy consumption.

MOCRN (Multihop-Based Optimal Cluster Heads Numbers Considering Relay Node in Transmission Range of Sensor Nodes in Wireless Sensor Networks) proposed in (Nam et al., 2013).

This protocol is based on the minimum separation distance between the cluster heads. Initially, MOCRN protocol randomly selects  $K$  nodes as its cluster heads (CHs). Every node selected as CH sends its information to the next node within its transmission range. The neighbour nodes that receive this information do likewise and transmit it to the next neighbouring nodes. The process continues until the node meets a neighbour node contained in another CH. Through this process, each local cluster is formed. The number of

clusters formed is the same as the number of cluster heads. Thus, choosing the number of CHs is the same as choosing the size of the cluster. In MOCRN protocol, the sensor network is divided into two clusters (intra-cluster and inter-cluster) based on the distances among the nodes.

*Intra-cluster:* During intra-cluster communication, each sensor node transmits data to its CH through a single hop. Energy dissipation by the CH is linearly dependent on the number of sensor nodes in each cluster. The smaller the size of a cluster, the lower the number of nodes and energy dissipation of the CHs. MOCRN protocol is energy efficient using a simple process for the formation of clusters. It selects CHs based on the minimum distance between the nodes. However, the method used by this protocol to select CHs is based on the distance between the nodes while the residual energy of the selected nodes was not considered. Selected nodes may not have enough energy to receive, aggregate, and re-transmit the data to the next CH or the base station. If this happens, data will not get to the destination resulting in loss of data. It is essential to consider the energy of nodes to be selected as CHs in addition to the distance between the nodes because of the extra functions performed by the CHs.

## **2.10 Medium Access Control Protocols for Wireless Sensor Networks**

Wireless sensor nodes are usually communicated by means of a unique channel. One of the characteristics of the channel is that only a single node can send a message at any given time. Therefore, to share access to the channel efficiently requires the establishment of a Medium Access Control (MAC) protocol among the sensor nodes. MAC is implemented at the data link layer of the protocol stacks. It is one of the vital issues that must be considered in the design of routing protocol for WSNs (Iannello et al., 2012). Data collision which is common in other wireless systems, is a great concern in WSNs. Collision occurs when two or more sensor nodes send their data at the same time over the same communication medium. To solve this problem, a MAC protocol can be used in the sensor network that will give access to the nodes to fairly and efficiently share the network resources among the sensor nodes and to avoid data collision from different nodes during transmission. Therefore, MAC protocol plays a vital role in ensuring normal network operations and achieving good network performance. MAC protocols designed for conventional wireless

networks such as mobile ad hoc network (MANET), and wireless cellular networks are primarily to provide quality of service (QoS) and bandwidth utilization while energy efficiency is of secondary importance. It has been shown that collision, control packet overhead, idle listening, and overhearing are the major sources of energy waste in MAC protocols (Incel et al., 2011). Therefore, MAC protocols designed for WSNs should avoid the above mentioned energy wastage and take into account other related factors mentioned below so as to provide good network services for different applications and to improve network performance. These factors include.

*Energy Efficiency:* Energy efficiency among other factors is one of the essential factors that must be considered in designing MAC protocol for sensor networks. Energy efficiency simply means energy consumed per unit of data transmitted successfully. MAC designed for sensor nodes must be energy efficient since they are battery powered and it may not be possible to recharge or replace the batteries from time to time when they are run out of energy.

*Adaptability:* MAC design for sensor networks must be able to accommodate the changes which occurred to the number of nodes and network topology. The changes can occur when a node dies, is removed or new nodes are added to the network (Zheng, 2009).

*Scalability:* Scalability refers to the ability to adapt to changes regardless of the network's size or the number of competing nodes. In WSNs, the number of sensor nodes deployed may be very large, (i.e hundreds to thousands of nodes). A MAC protocol must accommodate such changes in the network.

*Fairness:* MAC protocol designed for sensor network must be able to equally share a common transmission channel among the nodes without reducing the network throughput. It is desirable to achieve fairness among the nodes to achieve equitable quality of service and avoid a situation where some nodes will continuously be used more than other nodes. The network must accommodate different traffic which emanated from source nodes with various traffic generation patterns and a wide ranging quality of service requirements.

*Sensor-MAC (S-MAC)* protocol is one of the energy efficient MAC protocols designed for WSNs to minimize energy wastage caused by overhearing, collision, idle listening, and

control overhead (Ye et al., 2002). The main objective of S-MAC protocol design is to optimize energy efficiency and maintain good network scalability. To achieve this, S-MAC protocol reduces energy consumption of all source nodes that cause energy wastage. It incurs some performance reduction in both per hop fairness and latency by using different effective control operations in a contention-based MAC protocol based on IEEE 802.11 standard. The operations include periodic listen and sleep, message passing, collision avoidance and coordinated synchronization. To reduce idle listening, S-MAC introduces a low duty cycle operation using a periodic listen and sleep operation. The operations allow nodes to periodically move into sleep state for a period of time, wake up intermittently and listen if there is any new data in the network or check for the need to transmit to the next nodes. A node will remain in sleep state if it has no data to transmit or receive. It sets a wake up timer to awake at a later time. At the termination of the timer, the sensor node wakes-up and listens to see if there is any data to transmit in the network. A complete cycle of listen and sleep periods is referred to as a frame as shown in Figure 2.9.

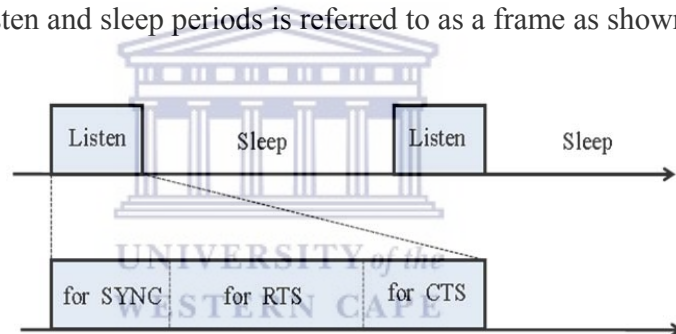

Figure 2.9: Periodic listen and sleep in S-MAC

An individual frame is characterized by a duty cycle defined as the ratio of the listen duration to the total time of a frame. However, the listen period is further sub-divided into smaller intervals for sending or receiving data. They are Synchronization (SYNC), Request to Send (RTS), and Clear to Send (CTS). In S-MAC, a node is allowed to freely choose its own listen and sleep schedules. However, a node selects its sleeping schedule and exchanges it with its neighbours periodically in order to have synchronized sleep schedules. Each node stores all the schedules of all its neighbours in a schedule table. Whenever a node attempts to transmit a message, it needs to first of all sense the channel. If the channel is busy, the node goes to sleep and wakes-up after some time to check if the channel is free. If the channel is free the sender node first sends RTS to its neighbours and

waits for a CTS message from a receiver, when a CTS message is received, the sender node sends its message to the next neighbor node. The process continues until the data gets to the destination.

A message contains meaningful and interrelated units of data which can be a long series of packets or a short series. A message is successfully transmitted when a sender node receives an acknowledgement from the receiver node. After RTS and CTS have been exchanged successfully between the nodes, the communicating nodes start to transmit packets and will not go to sleep mode until all messages have been successfully transmitted. Thus, S-MAC is energy efficient due to fixed sleep time and wake-up time ratio. Overhearing is avoided and provides good scalability.

However, the main shortcoming of S-MAC protocols is high latency message delivery that is; it takes a longer time before the message can be delivered which may increase energy consumption.

## **2.11 Techniques for Energy Optimization in Wireless Sensor Networks**

Recent technological developments in wireless technologies have led to the appearance of a new class of networks, known as Wireless Sensor Networks (WSNs), where individual sensor nodes cooperate wirelessly with each other with the goal of sensing and interacting with the environment. Low-cost deployment and self-organization are some acclaimed advantages of sensor nodes. WSNs have some challenges, these include limited computing capability, and a small memory with limited battery power (Gungor et al., 2010a).

The limited computing capability and small memory constraints in sensor networks will disappear due to the ongoing improvement to micro-electronics. However, the energy constraint is not likely to be solved soon because of the small size of the sensor nodes and the inclusion of real-time sensing into the sensor nodes.

Power management is a critical issue in wireless sensor networks because sensor networks are generally composed of nodes with limited energy. The power of sensor nodes is limited in two ways: Firstly, sensor nodes use small batteries as their main source of power.

Secondly, their power supplies cannot be refilled, this necessitates for the efficient and intelligent use of limited energy of sensor nodes so that they will remain functional for a longer time (Yi et al., 2011).

The following sections present three techniques used to optimize energy of sensor nodes in a network. The techniques are cross layer design, sleep mode transceiver, and hierarchical routing techniques.

### **2.11.1 Cross Layer Design Technique for Energy Optimization in WSNs**

Cross layer may be defined as, “*the breaking of OSI hierarchical layers and removing restriction between the layers by permitting one layer to access the data of another layer to exchange information and enable interaction in communication networks*” (Jagadeesan and Parthasarathy, 2012). It has been used in the ad hoc wireless systems to improve quality of service (QoS), throughput, and latency.

Sensor nodes are expected to remain functional for a longer period when they deployed in the target area. However, energy consumption during communication (i.e data transmission and reception) is much more than that used for computation and data sensing.

More energy is consumed as the transmission distance increases for large sensor networks (Singh et al., 2010).

Moreover, in order to minimize energy consumption, congestion control, efficient data dissemination, and network management in sensor networks involve all layers of the protocol stack either separately in every layer or jointly cross the layers (Vuran and Akyildiz, 2010).

Cross layer is one of the techniques used to minimize energy consumption in WSNs.

It is the interaction between different layers of the protocol stack. Each layer is informed about the conditions of other layers, while the structures of each layer still stay intact. The interactions between the layers are important for the design of communication protocols for WSNs.

#### **Rationale for Cross Layer in Sensor Networks**

The traditional protocol layers designed for wired communication perform very well for wired networks but they are not suitable for wireless sensor networks due to their unique characteristics (Miao et al., 2009). The model designed for the traditional protocol layers is called the Open Systems Interconnection (OSI) reference model. OSI is a layered structure for network systems that enables communication across all types of computer

systems, regardless of their underlying architecture (hardware or software). The model is partitioned into seven layers, and each layer performs specific functions (Dietrich et al., 2010; Saluja, 2012). The actual implementation of the layered architecture includes LonTalk protocol and Transmission Control Protocol/Internet Protocol (TCP/IP) protocol (Yu et al., 2009).

However, rapid increase in the adoption of wireless technology, coupled with the fast growing rate of the Internet, certainly shows increasing demand for wireless data services (Akbari et al., 2010). Wireless networks are in recent years a mixture of real-time and data traffic such as voice, images, tele-conferencing, games, video, and file transfers. All these applications require very diverse and widely varying quality of service (QoS) and need to be energy efficient.

Taking the advantage of the interactions and dependencies between layers of the OSI model, cross layer is considered as a base for protocol design for WSNs with the exclusion of two layers namely the session and presentation layers (Anastasi et al., 2009). The new protocol is called “generic protocol layers” designed for sensor networks as shown in Figure 2.10a.

Presently, there is no definite approach available to appraise particular protocol architecture, the long lasting existence and large deployment of the OSI model shows the reliability of the design as in the case of LonTalk Protocol or transmission control protocol/internet protocol (TCP/IP). It requires that the protocol architecture for WSNs needs to follow a layered architecture technique changing from traditional technique to *cross layer design* technique.

### **Cross Layer Approach for Wireless Sensor Networks**

Cross layer for WSNs violate the OSI reference model by merging the session and presentation layers to create new architecture.

The power consumption is reduced vertically through different layers and horizontally through the whole sensor network. The power consumption is not only reduced for a particular node, but also for the whole sensor network (He et al., 2010).

Consequently, optimization has to be done across all layers in WSNs, so as to prolong the network lifetime (Nayak and Stojmenovi, 2010) and this can be accomplished by

exchanging information at all layers. Sharing the information among all the layers will improve the overall network performance.

The development of an energy-efficient and reliable protocol stack is essential for supporting various WSN applications. In a sensor network, each sensor node uses the protocol stack to communicate with each other and with the base station (Yick et al., 2008). Therefore, the protocol stack must be able to work efficiently and be energy efficient in terms of communication across multiple sensor nodes (Melodia and Akyildiz, 2010). For instance, congestion control may affect only the transport layer, but sensor nodes energy saving may be related to the first five layers of the protocol stack.

The following section discusses the essence of designing the generic layered architecture for wireless sensor networks.

The protocol layered architecture is composed of five layers namely Physical layer, Data-link layer, Network layer, Transport layer, and Application layer as shown in Figure 2.10b.

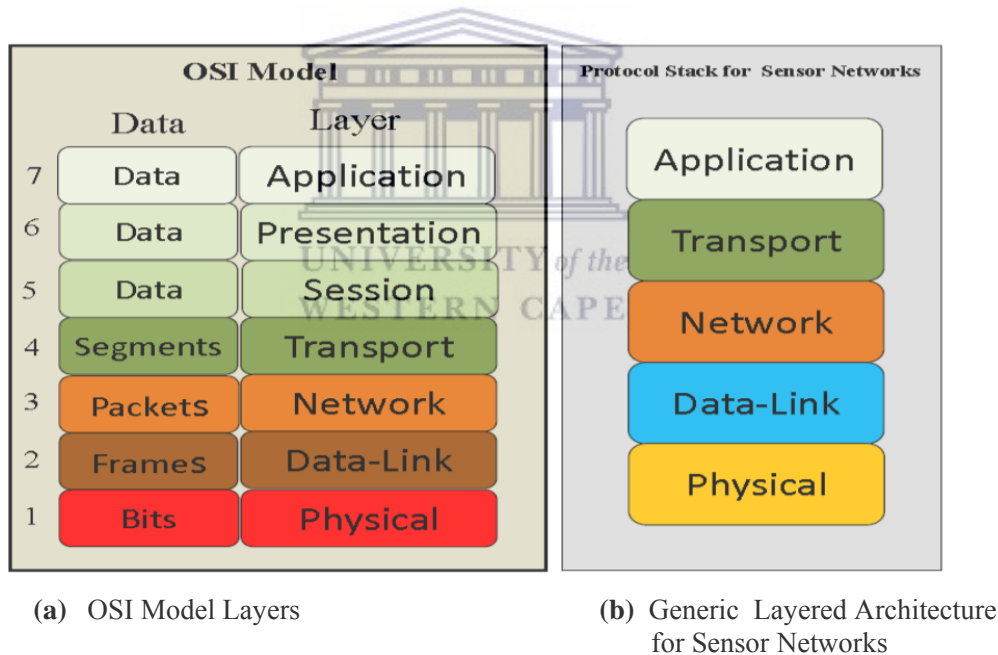

Figure 2.10: OSI model layers and sensor networks protocol stack



### ***Physical Layer***

The physical layer deals with the hardware and transmission of raw bits over a wireless channel (Newman, 2010). This layer is responsible for changing raw bit streams from the data link layer to signals that are appropriate for transmission over the communication medium. It is composed of different hardware modules for example, a radio in WSN. Radio allows a sensor node to communicate with the external world, and is the main source of energy consumption. Some of the factors that affect power consumption at the physical layer including different modes of operation are data rate, modulation scheme, and transmission of power. This layer is concerned with issues such as carrier frequency generation, signal detection, modulation, frequency selection and data encryption (Yu et al., 2009). The layer does not involve any extra packaging operations on the packet such as control and field headers.

### ***Data Link Layer***

The data link layer is responsible for encoding bits into packets before transmission and thereafter decoding the data packets back into bits at the destination. This layer performs functions such as, medium access and error control, data streams multiplexing, and data frame creation. It ensures reliable point-to-point and point-to-multipoint in a communication network. It is composed of two sub-layers: Media Access Control (MAC) and Logical Link Control (LLC). The main design objective of MAC is to fairly and efficiently share the communication links among multiple sensor nodes to achieve good network performance in terms of data delivery, network throughput and energy consumption. However, MAC protocols designed for the traditional wireless networks are not appropriate for WSNs because of their unique resource constraints and application requirements.

On the other hand, logical link control (LLC) is responsible for error control and flow control. Error control is used to ensure correctness of transmission and to take appropriate action in case of transmission errors. Flow control regulates the rate of data transmission to protect a slow receiver from being overwhelmed with data (Tang et al., 2011a).

At the Data-link layer, there are different sources of energy wastage, these include, overhearing, collision, idle listening, and control packet overhead (S. Liu et al., 2009).

Such sources of energy wastage do not pose problems in wired networks because of unlimited power supply. Thus, it is obvious that the performance of the whole wireless sensor network directly depends on the performance of the medium access and error control protocols used for the data link layer.

### ***Network Layer***

The network layer is responsible for the hop-to-hop routing and delivery of data. It provides addressing and routing services to the transport layer above it. The main functions of the network layer include information routing across network segments, network configuration, topology management, best route determination, and network layer addressing (Yick et al., 2008).

Routing protocols in WSNs differ from traditional routing protocols and wireless ad-hoc networks in several ways.

Firstly, due to the small physical size of sensor nodes, global addressing like classical IP-based routing cannot uniquely identify each sensor node in the network.

Secondly, in most cases, data are sent from different source nodes towards a destination node while in traditional systems, for example, in wireless ad-hoc networks, the source destination pair may change frequently. Finally, multi-hop communication in the wireless sensor networks consumes less power than the traditional single hop communication in a large network. These issues prompt a change away from traditional architectures.

### ***Transport***

The transport layer provides congestion control and end-to-end data transmission from source nodes to a destination in a reliable manner. It reduces or avoids the network congestion due to too much traffic flowing in the routers or other relay points. The transmission control protocol designed for transport layer protocols cannot be used for wireless sensor networks since they rely on end-to-end data delivery, acknowledgments and retransmission of data which wastes valuable energy resources (Felemban et al., 2010). The main objective of a sensor network also influences the design requirements of the transport layer protocols. However, design of transport layer protocols is a challenging

effort, because the specific application requirements and the limitations of the sensor nodes mostly determine the design principles of the transport layer protocols (Yick et al., 2008).

### ***Functions of Transport Layer in Wireless Sensor Networks***

*Reliable transport:* Based on the application requirements, data sensed by the nodes should be reliably transferred to the destination node.

*Congestion control:* Packet loss due to congestion can impair event detection at the base station even when enough information is sent from the source nodes. Hence, congestion control is an important component of the transport layer to achieve reliable event detection. Moreover, congestion control not only increases the network efficiency but also helps conserve scarce sensor network resources (Law et al., 2009).

*Self-configuration:* The transport layer protocols must be adaptive to dynamic topologies caused by node failure, temporary power down, node mobility and random node deployment.

*Energy awareness:* The transport layer functionalities should be energy aware, i.e., the error and congestion control objectives must be achieved with minimum possible energy expenditure. For instance, if reliability levels at the base station are found to be in excess of that required for the event detection, the source nodes can conserve energy by reducing the amount of information sent out.

### **Application Layer**

The application layer is the last layer of the protocol stack. It performs functions such as network management and query processing functionalities. At this layer, quality of service (QoS) is defined, the communicating partners are identified, data protection is performed, and user authentication and privacy issues are considered.

Moreover, due to the success of the layered architecture stack with the emergence of the internet, it has been adopted in the design of WSNs. However, the vast number of applications of WSNs shows that the wireless channel has a significant impact on the layer protocols. Consequently, the application-specific nature and resource constraints of the WSNs paradigm lead to *cross-layer* solutions that tightly integrate the layered protocol

stack (Du et al., 2010). By removing the boundaries between layers as well as the associated interfaces, increased energy efficiency and operating overhead can be achieved. The application layer assists the rest of the stack layers with hints that will help them optimize their performance in a cross-layer fashion.

Furthermore, several topology management solutions are needed to maintain the coverage and connectivity of the WSNs. The topology management algorithms provide efficient methods for network deployment that result in longer lifetime and efficient information coverage. Topology control protocols assist in determining the transmit power levels as well as the activity duration of sensor nodes to minimize energy consumption while ensuring network connectivity. The integration of each of the components for efficient operation depends on the applications running on the WSN. This application-dependent nature of the WSNs defines several unique properties compared to traditional networking solutions.

### **2.11.2 Sleep Mode Transceiver Technique**

Energy consumption is considered the most essential parameter contributing to the longevity of the sensor networks. Energy-efficiency is a major challenge in WSNs, as battery replacement can be difficult in unapproachable target areas. On the other hand, energy harvesting such as solar energy can only produce a limited amount of energy and its applicability is seasonal (Jurdak et al., 2010).

Sleep mode transceiver is one of the techniques used to minimize energy consumption in WSNs through the design of energy efficient Media Access Control protocols (MAC) (Tang et al., 2011b). MAC protocols designed for WSNs manage the usage of the interface to ensure efficient utilization of the shared bandwidth through low power wake-up radio protocols (Le-Huy and Roy, 2010), and duty cycling protocols (H. J. Choe et al., 2009). Radio is a major component contributing to the overall energy consumption at each sensor node.

One of the ways to minimize power consumption is by allowing the radio transceiver of sensor nodes to be in sleep mode when not transmitting or receiving any data. However, some sensor node radios support multiple sleep modes for instance the radio of sensor node

CC2420 has two different radio low power modes namely the deep sleep mode and the light sleep mode (Casilari et al., 2010).

**The deep sleep mode:** A node in deep sleep mode turns off its voltage and oscillator regulator when not transmitting data. This type of sleep mode consumes little energy. However, it has a longer latency and a high energy cost to change from the deep sleep mode to active mode.

**Light Sleep Mode:** Nodes in light sleep mode transiting to active mode is fast but draws more current.

Consequently, in a network with low traffic, it is more suitable to use the deep sleep mode since nodes spend more time sleeping than moving back and forth between sleep to active mode. Conversely, when the network traffic is high, it is not energy efficient for the nodes to be in deep sleep mode due to switching and high latency involved in constant wake-up. It is more suitable for the nodes to use a lighter sleep mode as they have to wake up constantly to receive and send data.

To address the trade-off between deep sleep and light sleep modes, (Jurdak et al., 2010) used an adaptive radio power model that systematically changed based on the current traffic conditions in the networks. The energy models consider all components contributing to sensor nodes energy consumption and determine optimal sleep mode selection for energy optimization in sensor networks.

Jurdak and others (Jurdak et al., 2010) developed models for major sources of energy waste in a wireless sensor node as follows.

### **Listening Energy**

The listening energy component is the energy consumed by the radio when in active mode but not sending or receiving any data. The listening energy of MAC protocols that are based on low power listening is modelled as follows:

$$E_L = \frac{S}{CK} * T_W * V * I_{listen} \quad (2.1)$$

where  $E_L$  is the listening energy,  $S$  is the sampling period,  $CK$  is the check interval,  $T_W$  is the time during which the node is awake every cycle,  $V$  is the supply voltage and  $I_{listen}$  is the current draw of the radio in listening mode.

### Switching Energy

The switching energy component is the energy consumed for transiting the radio state between different modes such as power down, normal and idle modes.

Energy consumed by radio switching from sleep mode to active mode is given by

$$E_{switch} = \frac{(I_{active} - I_{\alpha}) * T_{\alpha} * V}{2} \quad (2.2)$$

where  $I_{active}$  is the current draw by the radio when in active mode,  $I_{\alpha}$  is the current draw by the radio when in sleep mode  $\alpha$ , and  $T_{\alpha}$  is the time required for the radio to go from sleep mode to active mode.

### Transmission Energy

The transmission energy component is the energy consumed to transmit a unit of data packet from a source node to a destination node and the control overhead on the radio. The transmission energy can be expressed as follows

$$E_T = P_{sent} * P_{length} * T_B * I_t * V \quad (2.3)$$

where  $P_{sent}$  is the number of packets sent,  $P_{length}$  is the length of a packet in bytes,  $T_B$  is the time for sending one byte over the radio and  $I_t$  is the current draw of the radio, and  $V$  is the supply voltage while in transmit mode.

### Receiving Energy

The reception energy component is the energy consumed to receive a unit of data packet from the sender node and the associated overhead. It can be expressed as follows

$$E_R = P_{Recv} * P_{length} * T_B * I_r * V \quad (2.4)$$

where  $P_{Recv}$  and  $I_r$  are the number of packets received at the node and current draw of the radio while receiving data respectively.

### Sleeping Energy

The sleeping energy component is the energy consumed while the radio is in low power mode. It can be expressed as follows

$$E_{sleep} = T_{rf} * I_{\alpha} * V \quad (2.5)$$

where  $T_{rf}$  and  $I_{\alpha}$  are the time spent and current draw of the radio in sleep mode respectively

## **Total Energy**

The total energy consumption by each sensor node is the sum of all the above energy components given as

$$E_{total} = E_L + E_{switch} + E_T + E_R + E_{sleep} \quad (2.6)$$

Using this technique, energy waste caused by idle listening is minimized using different sleeping schedules. Secondly, the technique is simple to implement. Finally, using the global time synchronization overhead is minimized.

However, transceiver switching from a sleep mode to an active mode needs a finite amount of time to regulate voltages, synchronize, and register programs. This can lead to an increase in energy consumption and takes longer to synchronize.

### **2.11.3 Hierarchical Routing Technique**

Hierarchical routing protocols are some of the techniques that have been used to address scalability and to minimize energy consumption challenges in wireless sensor networks (WSNs). In a target area with a large number of sensor nodes, sensors cannot transmit their data over a long distance to the destination node due to their short distance transmission range. However, to efficiently transmit data in a large network, WSNs can be organized in a hierarchical structure and the nodes are partitioned into a number of groups called clusters. Building the hierarchy levels among the sensor network is known as clustering (Sendra et al., 2011). In a clustering mechanism, sensor nodes can be grouped together to form a cluster based on their closeness to each other or related services provided by the nodes. Each sensor node in a cluster is assigned different responsibility: a member node, cluster head or gate-way node. The member nodes are concerned with sensing, and transmission of sensed data to a cluster head or the base station. Cluster heads (CHs) collect data from all member nodes in their clusters and transmit the aggregated data to the next upper cluster heads until the data gets to the base station in hierarchical form. Moreover, the number of cluster heads per cluster may vary; it may be one or more depending on the number of sensor nodes in a network.

Gate-way nodes are nodes belonging to more than one clusters and their role is to collect data from the cluster heads and transmit it to the base station (Abidoye et al., 2011).

Sensor nodes with higher energy are usually selected as CHs to transmit the aggregate data to the gate way nodes while sensor nodes with low energy only transmit to the CHs over a short distance. However, sensor nodes have limited capabilities, clustering must be periodically performed in order to allow uniform energy distribution among the sensor nodes. Thus, formation of clusters reduce energy consumption, communication latency, routing overhead and improve scalability in large scale networks (Joo et al., 2010). Two-layer hierarchical cluster based architecture in WSNs is shown in Figure 2.11.

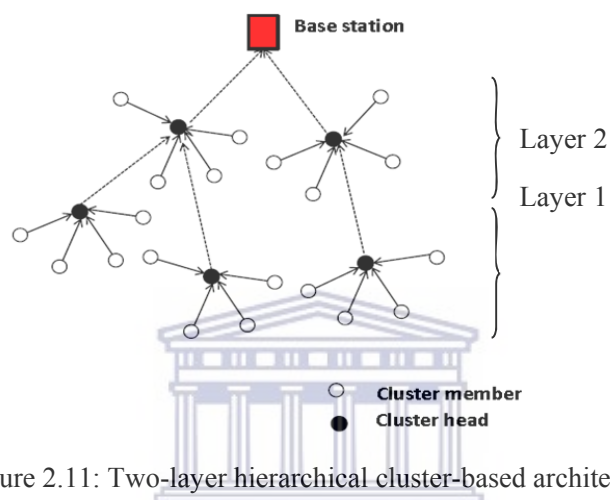

Figure 2.11: Two-layer hierarchical cluster-based architecture

Data transmission in hierarchical routing can be either through a single hop (or direct) or multi-hop (indirect) depending on the network size.

#### *Single-hop Data Transmission*

In a single hop transmission, data are transmitted directly from source nodes to the destination node without intermediate node that acts as relay nodes. The design of a single hop method could vary depending on the network topologies and application area. A protocol scheme may necessitate the sensor nodes to transmit directly to a base station (data collection center) or forms clusters among themselves so that, each member transmits its data to their respective cluster heads directly and cluster heads transmit the aggregated data to the base station. The advantage of single hop transmission is that the process involved in selecting relay nodes is avoided hence it saves energy. An example of this



protocol is the direct data transmission (DDT) (Bemana, 2012; C Intanagonwiwat et al., 2000a).

However, this method has many drawbacks. Firstly, when transmitting directly to a base station, sensor nodes that are far will use more energy to transmit their data and die quicker than nodes closer to the base station. This will quickly drain up sensor nodes energy and they will not be able to communicate again. The single hop transmission method is not energy efficient for a network involving hundreds of sensor nodes because each node will transmit to its group leader or a base station over a long distance and more energy will be consumed.

Although, if the base station is located within the sensing area, especially at the centre of the network, sensor nodes will use less energy to transmit to the receiver's node than when it is located outside the network area as shown in Figure 2.12.

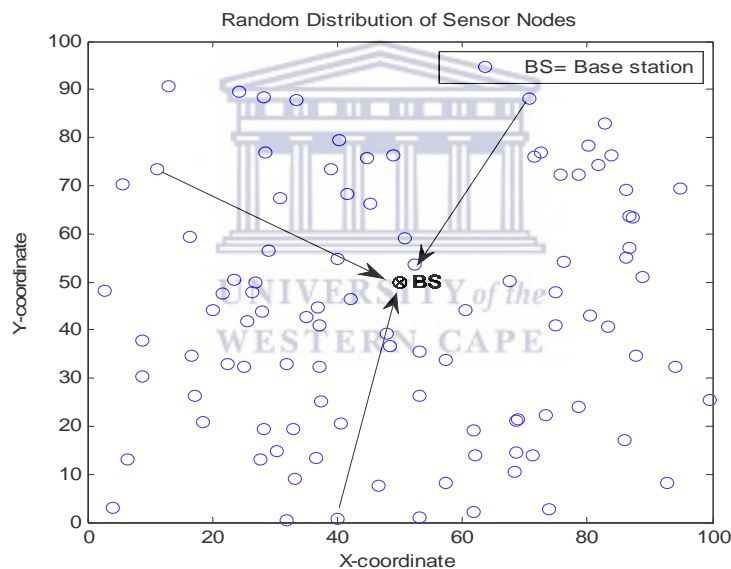

Figure 2.12: Direct data transmission Scheme

### *Multi-hop Data Transmission*

In multi-hop data transmission, sensor nodes transmit their sensed data to a base station through intermediate sensor nodes that act as relays between two communicating sensor nodes. Heinzelman and others in (Heinzelman et al., 2002) estimated that data with a transmission distance more than  $\frac{1}{\sqrt{2\beta}}$  should be transmitted through a relay node where  $\beta$  is the sensor node's density.

Sensor nodes in clustering transmit their data to a base station through the cluster heads. This reduces the transmission distance each node uses to transmit data to a base station by dividing the sensor network into finite  $K$  clusters.

A cluster usually has one or more cluster head(s) depending on the network size. Cluster heads (CHs) are responsible for transmitting the data received from the sensor nodes to the base station. Each node belongs to a cluster head that transmits with minimum energy. An example of clustering for WSNs is shown in Figure 2.13

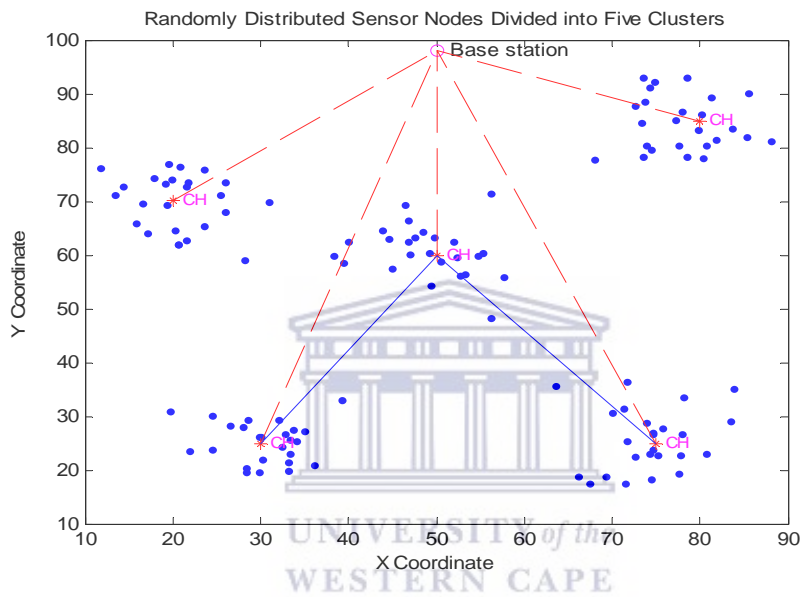

Figure 2.13: Clustering technique for wireless sensor networks

We propose a power consumption model for multi hops with equal and unequal distances between sensor nodes based on the minimum power consumption model proposed by (Q. Wang et al., 2006). The power consumption model for multi hops with unequal distance is expressed as

$$P(n) = n(n - 1)P_{Rx} + nP_{Tx} + \varepsilon/\beta \sum_{i=1}^n d_i^\alpha \quad (2.7)$$

Similarly, the power consumption model for multi hops with equal distance between sensor nodes is expressed as

$$P(n) = n(n - 1)P_{Rx} + nP_{Tx} + \frac{\varepsilon * n * (R/n)^\alpha}{\beta} \quad (2.8)$$

where  $n$  is number of hops,  $P_{Rx}$  watts is power consumption for receiving data,  $P_{Tx}$  watts is power consumption for sending data to the next node through distance  $d$  meters is represented by  $P_{Tx}(d_i)$  for all  $i \in \{1, 2, \dots, n\}$  hop.

$P_{Tx}(R/n)$  describes power consumption for sending data over a distance  $R/n$  as shown in Figure 2.14. The total power consumption to transmit from source node (S) to the destination node (D) over  $n$  hops is  $P(n)$ .  $\epsilon$  is a constant,  $\beta$  is the drain efficiency,  $\alpha$  is the path loss exponent in the range 2 or 4. However, the drain efficiency of real devices typically increases as the output power of the transmission increases up to its designed target output power (Q. Wang et al., 2006).

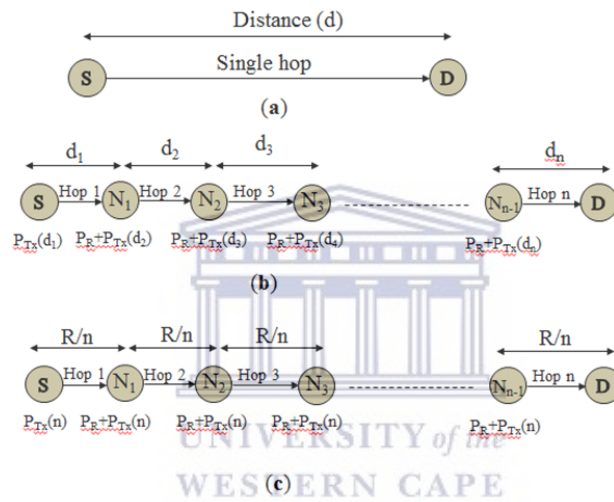

Figure 2.14: Power consumption model

## 2.12 Method of Data Aggregation

Sensor nodes sense and measure changes in the area of interest in sensor networks. Sensed data are transmitted to the base station via intermediate nodes and analyzed by the end-user(s). The results of the analysis allow end-user(s) to get useful information about the environment being monitored. For instance, when sensor nodes are deployed in an area for surveillance purposes, the end-user only needs to know whether or not there has been an intrusion in the area, he does not need to see how the data were transmitted among the nodes. Data aggregation is performed by sensor nodes to reduce sensed data into a small set of data packets (Mitchell, 2012; Zhu et al., 2012). It eliminates redundant data to produce a more precise signal by removing uncorrelated noise to reduce information overload. Data

sensed by the individual sensor nodes  $S_i[n]$  are filtered with weighting filters  $w_i[n]$  to get accurate signal  $z[n]$  as shown in Figure 2.15.

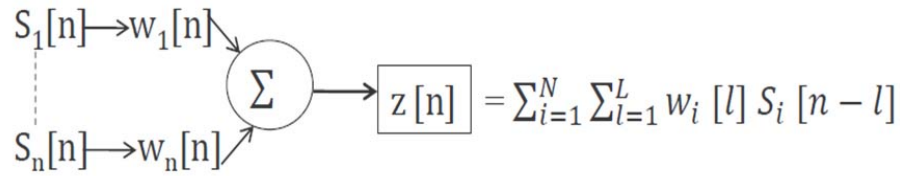

Figure 2.15: Data Aggregation using Beamforming algorithm

One approach of aggregating data is called beamforming (Bertrand and Moonen, 2012; Harb, 2011). Beamforming or spatial filtering is a signal processing method in sensor arrays for directional signal transmission and reception. It combines signals from multiple sensor nodes as follows

$$z[n] = \sum_{i=1}^N \sum_{l=1}^L w_i[l] S_i[n-l]$$

where  $w_i[n]$  is the weighting filter for the node  $i$ th signals,  $S_i[n]$  is the signal from  $i$ th sensor node,  $N$  is the total number of nodes whose signals are being beamformed and  $L$  is the number of taps in the filter.

However, when the clusters are formed, data transmission begins. Sensor nodes use single hop or multi hops to communicate to the next nodes or to the closest cluster heads which in turn communicate with the base station where each node transmits  $q$  – bit of data to the next node. The data aggregation technique has proved effective for optimal data transmission as shown above and in achieving energy efficiency for different routing protocols.

Moreover, some of the hierarchical routing protocols proposed in the literature are energy Efficient Hierarchical Clustering for Wireless Sensor Networks (EEHC), Energy Balancing and Dynamic Hierarchical Routing Algorithm for Wireless Sensor Networks (EBDHR) and Low Energy Adaptive Clustering Hierarchy Protocol (LEACH).

## **Energy Efficient Hierarchical Clustered Scheme for Wireless Sensor Networks**

An energy efficient hierarchical clustered scheme for wireless sensor networks (EEHC) (D. Kumar et al., 2009) is a distributed, randomized clustering algorithm that partitions the sensor nodes in a network into different clusters with a hierarchy of cluster heads. Sensor nodes in each cluster transmit their sensed data to their respective cluster heads. The CHs add its own data to the data received from member nodes and transmits the aggregated data to the base station. The method used to select CHs is based on probability ( $P$ ). Energy consumed by the network for transmitting the data collected by the sensor nodes to the base station depends on:

The probability of each node becoming a CH at each level in the hierarchy and;

The maximum number of  $k$  – hop allowed between each cluster member node and its CH.

Therefore, the total energy cost of transmitting data from the sensor nodes to the base station is the energy consumed by the nodes to transmit data to the level-1 CHs plus the energy used to aggregate data by level-1 CHs and transmits the data to the base station through  $h$  –hop CHs at different levels. The EEHC algorithm has a time complexity of  $O(k_1 + k_2 + \dots + k_h)$  where  $k_i$  is the  $k$  –hop the distance between member nodes and their cluster head at level  $i$  for all  $i = 1, 2, 3, \dots, h$ . The EEHC approach reduces energy consumption in sensor networks. However, EEHC method of cluster head selection is based on probability, and energy consumption by the nodes may not be uniformly distributed within the networks.

## **Energy Balancing and Dynamic Hierarchical Routing Algorithm for Wireless Sensor Networks (EBDHR)**

EBDHR is another dynamic and hierarchical routing algorithm proposed in (Heikalabad et al., 2010) to minimize energy consumption in sensor networks. The method used for cluster formation and election of cluster heads (CHs) is similar to the LEACH protocol discussed in section 2.9.3. However, the main difference is that EBDHR first considers the distance between the CHs and the base station before data is transmitted. The algorithm eliminates rapid energy consumption of CHs near the base station and allows uniform distribution of energy consumption in the sensor networks. However, the EBDHR

algorithm is only energy efficient when the base station is at the centre. Sensor nodes will consume large amount of energy if the base station is located outside the network area.

### **An Energy-Efficient Clustering Routing Algorithm Based on Distance and Residual Energy for Wireless Sensor Networks**

DECSA (A distance-energy cluster algorithm) (Yong and Pei, 2012) is an improvement on LEACH protocol. DECSA considered both the residual energy of nodes and the distance in the process of selecting cluster heads (CHs) and cluster formation. The authors used a three level hierarchy structure network model to divide the sensor networks into four categories: common sensor nodes (SN), cluster head node (CH), Base station cluster head (BCH), and Base station (BS). The selection of CHs depends on a random number generated by each sensor node and which must be less than the predefined threshold,  $T(n)$ . The sensor node with the highest probability becomes a CH which depends on the node's residual energy. This protocol avoids direct communication between the CH and the base station, if the communication distance is greater than the threshold value. It reduces energy consumption by 40%, prolongs the network's lifetime by 31% and performs better compared to the LEACH protocol. However, the cluster heads selected based on this approach are not uniformly distributed within the network, and there is a high probability for the selected CHs to be on the same side of the network resulting in an increase in energy consumption.

### **2.13 Heterogeneous Sensor Networks**

All the discussions about the wireless sensor networks above were based on homogeneous networks. In this type of network, all sensor nodes have the same capability and the cluster heads need to be constantly rotated among the nodes after a number of rounds. This is to prevent nodes, who have been cluster heads for a given period, from draining their energy beyond threshold value due to the extra functions they perform, such as data fusion and data retransmission.

However, many large scale networks found in communications, engineering, sociology or biology have heterogeneity in their various properties and the functionality of the sensor node is application specific. Some sensor nodes can be equipped with more energy to perform more comprehensive tasks than other nodes in a network. For instance, some

nodes can be used to collect an audio signal, video, and so on. The composition of two or more different sensor nodes in terms of energy or service delivery create heterogeneous sensor networks. This type of network can be used to monitor a remote environment, healthcare, engineering, and military applications. This research has been extended to include heterogeneous sensor networks. A comparative study of homogeneous and heterogeneous clustered sensor networks is contained in (Ehsan and Hamdaoui, 2012).

*Below are brief reviews of previous heterogeneous protocols for wireless sensor networks.*

Energy efficient heterogeneous clustered scheme for wireless sensor networks (EECH) protocol (D. Kumar et al., 2009). This protocol assigned a fraction of the network population with additional energy. It chooses cluster heads based on the weighted election probability of the individual node related to the initial energy. Sensor nodes with more energy have a higher probability to be selected as cluster heads (CHs). However, energy consumption of this protocol cannot be predicted, hence its performance is limited. On the other hand, there is a high probability that the selected cluster heads will be on the same side of the network. If that happens, sensor nodes far from the CHs will transmit through a long distance and more energy will be consumed.

Moreover, a novel stable selection and reliable transmission protocol for clustered heterogeneous wireless sensor networks (Zhou et al., 2010) is an heterogeneous protocol based on the method of energy dissipation forecast and clustering management (EDFCM). The network model is composed of three kinds of heterogeneous sensor nodes. Sensor nodes in this network have two ordinary types of nodes: type\_0 and type\_1. Type\_0 nodes are sensing nodes used to measure changes in the environment and transmit the sensed data to the data collector centre. Type\_1 nodes have more complex software and hardware architectures which give the nodes more processing power, a higher data transfer rate and more initial energy than type\_0 nodes. However, the method used for cluster heads selection is based on the forecast of energy consumption of the previous round, and if the value is not correctly predicted, more energy will be consumed.

EEPCA is an energy efficient prediction clustering algorithm for multilevel heterogeneous wireless sensor networks (Peng et al., 2013). The algorithm allows each sensor node to select itself as a potential cluster head based on the communication cost and energy factor.

Sensor nodes with more residual energy have a better chance to be selected as cluster heads. The results show that EEPKA has a better network monitoring quality and achieve a longer lifetime compared with previous heterogeneous protocols. However, much overhead is incurred in the process of selecting subsequent cluster head nodes.

## 2.14 Computational Intelligence

Computational Intelligence (CI) is a successor of artificial intelligence, closely related to soft computing. It is the study of adaptive mechanisms to enable or facilitate intelligent behaviour in a complex and changing environment (Engelbrecht, 2007). It is based on nature inspired computational methodologies and techniques to solve complex problems of real world applications where traditional approaches and methodologies such as black box, probabilistic, and first principles are infeasible or ineffective. Computational intelligence is composed of five main paradigms namely: Evolutionary Computation (EC), Neural Networks (NN), Fuzzy Systems (FS), Swarm Intelligence, and Artificial Immune Systems (AIS). Each of these paradigms has its origin in biological systems and probabilistic methods are commonly used with each of the paradigms as shown in Figure 2.16 (R Eberhart and Shi, 2007). CI encompasses elements of learning, heuristic, adaptation, meta-heuristic optimization, and hybrid methods which use a combination of one or more of these techniques. CI techniques have been successfully applied in many application areas including genetic clustering and classification, decision support systems, stock markets, consumer electronic devices, combinatorial optimization, medical, bioinformatics and biomedical problems, time series predictions, and wireless sensor networks (R Eberhart and Shi, 2007; R. V. Kulkarni et al., 2011; H. Liu et al., 2012; Valle, 2008). The characteristic of “intelligence” was initially attributed to humans; in recent time, many products and items also claim to be “intelligent”. The term intelligent means the ability to learn about, learn from, understand, reason, interact with one’s environment and make decisions.

However, among all these paradigms, swarm intelligence which is one of the techniques used in this research will be discussed.



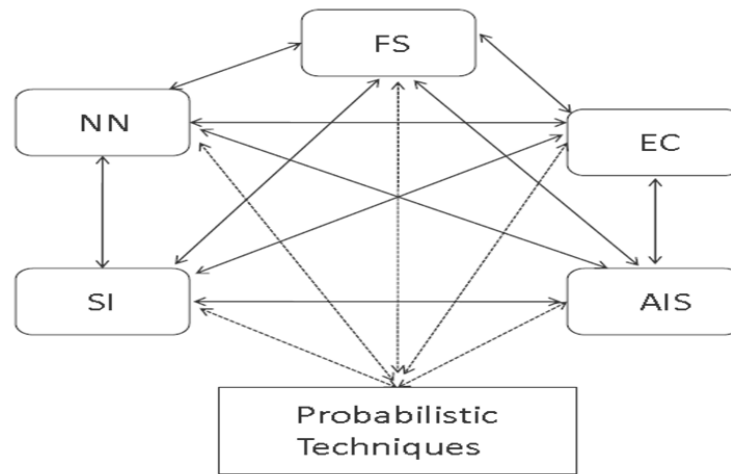

Figure 2.16: Computational intelligence paradigms

### 2.14.1 Swarm Intelligence

Swarm intelligence (SI) is the collective behaviour of decentralized, natural or artificial self-organized systems. SI system basically consists of a population of simple agents interacting locally with one another and with the environment (Marco Dorigo, 2010). The term “swarm” in a general sense means the interaction between loosely organized large groups of small moving organisms. There are five main principles guiding the operations of SI as identified by (Hiot, 2010). They are

- The *quality* principle: The population should be able to respond to quality factors in the environment.
- The *proximity* principle: The population should be able to carry out simple space and time computations.
- *The principle of diverse response*: The population should not conduct its activity along excessively narrow channels.
- *The principle of adaptability*: The population must be able to adjust to the new environment.
- *The principle of stability*: The population should not change its mode of behaviour every time the environment changes.

Swarm Intelligence was first used in the context of cellular robotic systems, where many simple agents occupy one or two-dimensional environments to generate patterns and self-organize through nearest neighbour interactions. Its inspiration comes from biological systems in which the agents follow simple rules without a centralized control structure guiding how individual agents should interact with one another. The collective interaction of the individual agents helps them to solve complex task which could not be normally be achieved by a single individual acting alone.

Swarm intelligence can be broadly divided into two

- (1) Social insect societies examples include ants, termites, wasp, bees.
- (2) Animal societies examples of which include schools of fish, flocks of birds, herds of land animals and crowds of people.

The following features are common to a typical swarm intelligence system.

- i. The system consists of many individual agents.
- ii. Individuals communicate in a localized way based on simple behaviour rules without any central control.
- iii. The system is constantly responding to changes in the environment.
- iv. The individuals are relatively identical (i.e they are either belong to a few topologies or all are identical).

However, many social insects achieve their communal goals through a purely bottom-up approach without any instruction from a leader contrary to the top-down approach that is seen in organization control by human beings. These simple agents have no leaders, and on aggregate, they can accomplish a task that serves the interest of the whole colony through the contribution of each member based on the local rules available to the agents.

#### **2.14.2 Metaheuristics**

In computer Science, metaheuristics are computational methods designed to solve complex optimization problems by iteratively improving the candidate solution to achieve good quality solutions within a shortest time where other optimization methods are either not efficient or effective (Gendreau, 2010). The term *metaheuristic* was first introduced in 1986, derived from the composition of two Greek words. Heuristic derives from the verb

*heuriskein* which means “to find”, while the prefix *meta* means “beyond in an upper level”. Metaheuristics were initially called modern heuristics before this term was generally adopted. A metaheuristic structure is basically based on simulating nature and artificial intelligence tools. It invokes exploitation and exploration search methods for the problem being optimized and can search all over the search spaces of candidate solutions. Therefore, metaheuristics cannot converge into local minima although it is computationally costly due to their slow convergence (Mohanad, 2010). One of the reasons for slow convergence is that the directions for the optimal search may not be found, especially in the vicinity of local minima due to their random construction. Metaheuristics can be classified into two search methods based on the process of updating solutions.

*Point-to-Point method* – this search method keeps one solution at the end of each iteration where the next search iteration begins.

*Population-based method* – this search method keeps a set of many solutions at the end of each iteration.

The following are metaheuristic search algorithms: evolutionary computation, Tabu search, simulated annealing, iterated local search, Ant Colony Optimization (ACO), Particle Swarm Optimization (PSO), solution-to-solution search (Marco Dorigo, 2010; Gendreau, 2010). The metaheuristic approach provides heuristic solutions to combinatorial optimization problems with little inherent structure and many local solutions to guide the search. This approach starts to solve a problem by obtaining an initial solution or set of solutions and subsequently improving on the initial search based on certain principles. The most notable examples of optimization techniques inspired by swarm intelligence are: Particle Swarm Optimization (PSO) and Ant Colony Optimization (ACO).

### **2.14.3 Particle Swarm Optimization**

Particle Swarm Optimization (PSO) is a population based stochastic technique for solving continuous optimization problems (RC Eberhart and Kennedy, 1995). This technique is motivated by the social behaviour of a flock of birds and schools of fish. It shares many similarities with evolutionary computing (EC) techniques such as Genetic Algorithms (GAs). PSO operates with the initial population of random solutions and searches for

optimal solutions by updating generations. Moreover, unlike evolutionary computing, PSO does not use evolutionary operators such as mutation and crossover. In a PSO system, a swarm of individuals (called *particles*) search through the whole problem space by following the immediate optimal particles. Each particle keeps track of its next position in the search space following simple rules. Particle movements are guided by their own search experience in the search space as well as the best experience of the particles located in swarm. However, when a particle takes all the population as its topological neighbours the best value among the solution is a global best.

PSO consists of a population of  $p$  particles as shown in Figure 2.17. These particles represent an approximation of the desired solution (Kulkarni and Venayagamoorthy, 2011). A PSO problem is basically modeled as  $n$ -dimensional solution space and the particles explore this  $n$ -dimensional space in search for an optimal solution. The number of dimensions depends on a given problem.

A particle simulates an individual bird in a flock. The velocity of each particle (bird) is modified iteratively by the best position found by the particle so far (its personal best position) and the best position found by the particles close to them (Blum and Li, 2008). Thus, each particle searches around a region defined by its personal best position and the best position from its locality.

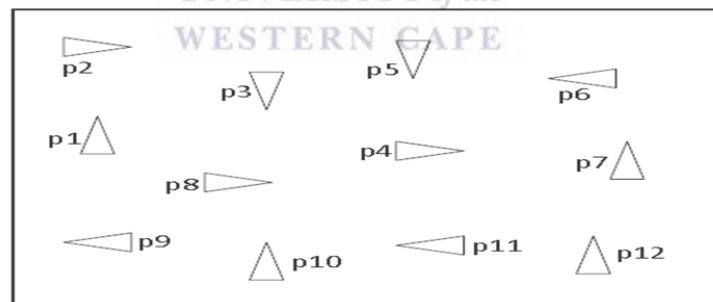

Figure 2.17: Particle Swarm (Population =12) in a 2-dimensional space

Each particle  $i$  in the swarm occupies a current position  $x_{id}(t)$  at time step  $t$  in the  $n$ -dimensional vector space and moves with a velocity  $v_{id}$  that shows its direction and speed at time step  $t$  for all  $1 \leq i \leq p$  and  $1 \leq d \leq n$ . Particles are randomly assigned initial positions and velocities within fixed boundaries as  $x_{min} \leq x_{id} \leq x_{max}$  and  $v_{min} \leq v_{id} \leq v_{max}$  respectively. The position of a particle determines its fitness value; a

particle nearer to the solution has higher fitness value than a particle that is farther away. Positions of all particles and velocities in each process are updated to achieve better fitness. The process continues iteratively until either a sufficiently large number of iterations are obtained or a particle has reached the global solution (R. Kulkarni et al., 2011). Every particle  $i$  in the swarm has a memory which stores the current best position  $pbest_{id}$  that the particle has found since its search started. In addition, global best position  $gbest_{id}$  can be accessed by any particle.  $gbest_{id}$  is the particle's position where the fitness value is the highest. In each iteration  $k$ , particle location  $x_{id}$  and velocity  $v_{id}$  are updated and move towards its personal best  $pbest_{id}$  and global best  $gbest_{id}$  using the equations (2.9) and (2.10) respectively (Leonard and Engelbrecht, 2012).

$$v_{id}(k + 1) = w * v_{id}(k) + c_1 * rand_1 * (pbest_{id} - x_{id}) + c_2 * rand_2 * (gbest_{id} - x_{id}) \quad (2.9)$$

$$x_{id}(k + 1) = x_{id}(k) + v_{id}(k + 1) \quad (2.10)$$

where  $rand_1$  and  $rand_2$  are random numbers with values ranging from zero to one i.e [0,1]. The inertial weight  $w$  is a predefined positive value that is decreased linearly in each iteration to slow down the speed of the particles which are gradually coming closer to the global best particle. The variables  $c_1$  and  $c_2$  are acceleration coefficients.  $c_1$  steers the particle towards the position where the fitness is the highest and  $c_2$  propels the particle towards the particle that currently has the highest fitness. Figure 2.18 shows a PSO schematic diagram. Particle position is bounded by properly selected constants  $x_{min}$  and  $x_{max}$ . Similarly, the velocity of a particle is restricted between properly chosen  $v_{min}$  and  $v_{max}$ .

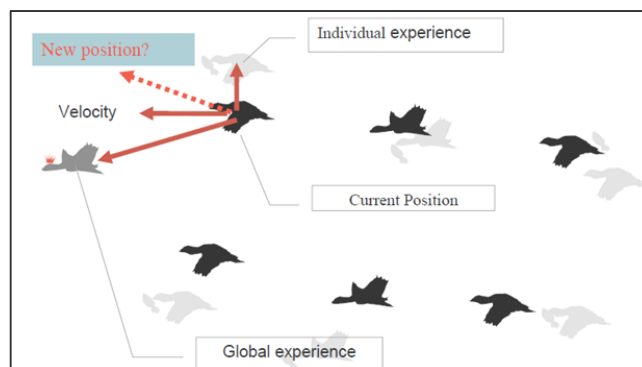

Figure 2.18: Particle swarm organization schematic diagram (R.-M. Chen, 2011)

### *Advantages of Particle Swarm Optimization*

Particle swarm optimization (PSO) is very easy to implement and it has been applied successfully to solve many optimization problems including antenna control, power system, stock markets, and wireless sensor networks (R Eberhart and Shi, 2007; R. Kulkarni et al., 2011).

In recent years, wide application areas of PSO have roused the interest of research communities because it is more appropriate to process different types of optimization problems compared with existing optimization methods. It provides better solutions much faster than other evolutionary algorithms (Ali et al., 2012; Lazinica, 2009; Malik et al., 2007).

Other PSO advantages include

Variables in the PSO algorithm can easily be varied without a decrease in system performance.

Secondly, there are few parameters to adjust in the PSO algorithm. The algorithm contains two parameters: lower and upper bound vectors and the fitness function which directs the swarm towards the best solution.

Thirdly, PSO has no mutation and overlapping calculations. The search can be carried out by the speed of the particles and only the fitness particles can transmit information to other particles without compromising the speed.

Fourthly, the PSO algorithm is very efficient for global search, making it suitable for real-time graphics applications such as animations.

Finally, the PSO solution is decided directly using a real number code, and the number of the dimension is equal to the constant of the solution (Bai, 2010).

However, as PSO is a new search optimization technique, research is ongoing on to improve the original PSOs so that they are able to solve different types of problems. PSO is similar to evolutionary computation (EC) methods, the EC ideas and techniques may be integrated together to further improve PSOs. PSO is applicable to both unconstrained and constrained problems even without pre-transforming the objectives and the constraints of a problem (R Eberhart and Shi, 2007).

### *Weaknesses of Particle Swarm Optimization*

Firstly, as the number of iterations increases, the quality of the solutions cannot usually be improved and may converge prematurely. The reason behind this problem is that for global best (*gbest*) PSO, particles converge to a single point, which is on the line between the current best and the global best positions. It has weak local search ability for multimodal problems where the problems have multiple optimal solutions.

Secondly, PSO has a fast rate of information flow between the swarm, resulting in the formation of similar particles which increases the chances of being trapped in local optimal.

Finally, PSO is not efficient for problems of a non-coordinate system such as the moving rules of the particles in the energy field (Y. Chen et al., 2006). Thus, researchers need to be aware of these weaknesses when developing new algorithms for solving optimization problems.

#### **2.14.4 Ant Colony Optimization Scheme**

Dorigo Marco (Marco Dorigo, 1992) proposed Ant System (AS) and was the first Ant colony optimization algorithm to be proposed in the literature. It was used to solve the Travelling Salesman Problem (TSP) with the main objective to find a minimum length tour joining  $n$  cities. The ant system provides an efficient solution for small size problems within a reasonable time. Dorigo and Gambardella (M Dorigo and Gambardella, 1997) introduced the Ant Colony System (ACS) algorithm to improve the performance of the Ant System for large-size problems. The modifications of ACS made to Ant System are:

- improve the transition rule of the AS;
- a different pheromone trail update rule;
- the use of local updates of pheromone trail to favour exploration;
- the use of a candidate list to control the choice of which neighbouring city to visit.

However, both the AS and ACS have been used in many applications including the Quadratic Assignment Problem (QAP) (M. Dorigo, Birattari, M., Blum, C., Clerc, M., Stützle, T., Winfield, A, 2008), to solve Unequal Area Facility Layout Problems (UA-FLPs) (Wong, 2010), NP-hard combinatorial optimization problems (Gambardella and Dorigo, 1997), the traveling salesman problem (TSP) (Marco Dorigo, 1992) and so on.

Moreover, Dorigo later generalized the ant colony system into the ant colony optimization (ACO) metaheuristic for solving combinatorial optimization problems. It is one of the examples of swarm intelligence consisting of simple particles (individuals) cooperating with one another through self-organization without any members of the colony being controlled centrally. The development of ACO algorithms was inspired by the observation of ant colonies. Ants are social insects; they live in colonies and their behaviour is governed by the goal of colony survival rather than being focused on the individuals' survival. The behaviour that brought about the inspiration for ACO is the ants' foraging behaviour, which is how ants can discover the shortest path between their nest and the food source. When ants are searching for food, they initially search the area surrounding their nest in a random way. While moving, ants deposit a chemical substance called pheromone trails on their path as they are moving, - this substance is used to communicate indirectly. As soon as an ant discovers a food source, the quantity and the quality of the food is evaluated and the ant carries part of the food back to the nest. When coming back, the chemical deposited on the ground will guide other ants and more ants will follow a path with a high concentration of pheromone trails to the food source as shown in Figure 2.19. There is a high probability that the ants will follow a path with strong pheromone deposits. The number of ants choosing the shortest path is more likely to be more than ants taking the longer path and more pheromone will be deposited as they are moving from their nest to the food source (R Eberhart and Shi, 2007).

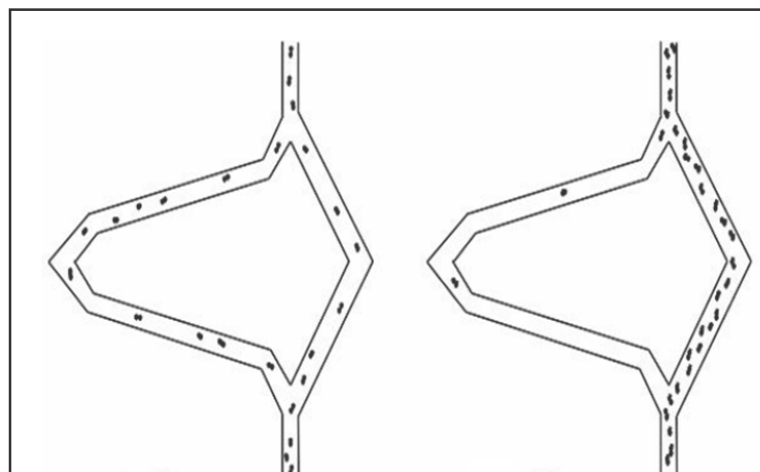

Figure 2.19: Ants find the shorter path



Moreover, (Fathima and Sindhanaiselvan, 2013) applied the ACO model to solve energy problem in wireless sensor networks; the algorithm developed considered the energy sufficiency of each node based on transition probability as given in equation (2.11).

$$P_{ij}^k = \frac{\lambda_{ij}^\alpha \cdot \eta_{ij}^\beta}{\sum_{l \in N_i, l \notin M^k} \lambda_{ij}^\alpha \cdot \eta_{ij}^\beta} \quad (2.11)$$

where  $\eta_{ij} = \frac{E_j}{\sum_{l \in N_i} E_l}$ .  $\eta_{ij}$  denotes the local heuristic value of the link  $(i, j)$ , metric,  $E_j$  is the current energy of node  $j$ ,  $\lambda_{ij}$  is the pheromone value on link  $(i, j)$  and  $M^k$  is a tabu list of nodes already visited by ant  $k$ . The parameters  $\alpha$  and  $\beta$  are used to control the relative weight of the pheromone trail and the heuristic value respectively. A node which has more energy has a higher probability of being selected as the relay node. Energy balance is achieved using this approach.

## 2.15 Simulation Techniques

Different techniques developed for wireless sensor networks (WSNs) are tested by using one of the following methods: (1) analytical methods, (2) test beds, or (3) simulations (Prasad and Son, 2007).

*Analytical modeling* provides a quick understanding for the methods developed for WSNs. It provides an abstract view of the software and hardware. However, this method fails to provide accurate results due to the complexity and constraints of WSNs (Sundani et al., 2011).

*Test bed* is a real implementation and the most precise approach to evaluate the concepts being investigated. It involves the deploy of a sensor network in a realistic environment. It provides the realism exigent to understand communication loss, resource limitations and energy constraints at scale. However, test bed is constrained by high costs and time factors (Rachedi et al., 2012).

*Simulation* is presently the most commonly used method for analyzing WSNs. It allows quick appraisal, optimization, and adjustment of proposed protocols within a short period and at low cost. Simulations for WSNs require a physical environment, precise energy models and implementation of a radio channel.

In the following section we provide overview, strengths and weaknesses of some of the simulators used for WSNs.

### **NS-2**

The Network Simulator (NS-2) (Issariyakul and Hossain, 2011) is an object oriented discrete event simulator targeted at networking research. It is the most commonly simulation tool used for sensor networks and has a rich library of protocols but mainly on IP networks. It provides good support for the simulation of routing transmission control protocols (TCP) and multi-cast protocols over wired and MANETS.

*Strengths:* the extensibility of NS-2 has made it very powerful for sensor networks. In addition, its design is based on object oriented which facilitates easy creation and use of new protocols.

*Weaknesses:* NS-2 simulator is limited by its scalability and lack of application stack layer model. Moreover, its design introduces unnecessary inter-dependence between modules.

### **OMNET++**

OMNET++ (Varga and Hornig, 2008) is a discrete event that is component based and is a general purpose network simulator written in C++. It's structure is based on a modular system: simple modules contain algorithms making up the lowest level of hierarchy. The compound modules contain simple modules that interact with each other using messages.

*Strength:* It provides strong graphical user interface (GUI) support for debugging and animation.

*Weakness:* It does not provide a specific module library for WSNs that can assist in the design process.

### **OPNET**

OPNET Modeler is an object oriented network simulator, it was initially developed for use by the military. Presently, it is among the world's leading commercial network simulation tool. It supports discrete event, analytical, and hybrid simulations.

*Strength:* It provides a very good set of modules for all layers of the protocol stacks, including IEEE 802.11 family.

*Weaknesses:* Due to extensibility and scalability, it is not widely used for wireless sensor network simulation. Secondly, it is very expensive to procure.

## **MATLAB**

MATrix LABoratory (MATLAB) is a multi-paradigm numerical computing environment developed by MathWorks (Moler, 2004). It is an interactive software package that allows numerical calculations, plotting of functions and data, matrix manipulations, implementation of algorithms, creation of user interfaces, and interfacing with programs written in other languages, such as FORTRAN, C, C++, and Java. Its language makes it quite easy to code complicated algorithms involving matrix, vector formulations and for solving complex graphics in two and three dimensions. MATLAB is widely used in research, economics, and academic institutions as well as industrial enterprises.

*Strengths:* MATLAB is relatively easy to learn and its errors are easier to fix.

It contains a wide variety of toolboxes which make it easy to perform a wide range of applications in the spheres of engineering, science and economics (Overman, 2011).

Secondly, it allows the testing of the algorithms immediately without recompilation.

Thirdly, it allows one to work interactively with data, and helps to keep track of files and variables.

*Weaknesses:* MATLAB is designed for scientific computation and is not suitable for GUI.

Secondly, it is not a general purpose programming language. Based on the advantages of MATLAB software over other simulators; it will be used in simulating our proposed models and protocols in this research.

## 2.16 Chapter summary

This chapter provides a detailed review of literature that deals with the unique characteristics, challenges, and application areas for wireless sensor networks. We discussed and classified the network architectures into two parts. Different routing protocols were debated; the advantages and shortcomings of the protocols were highlighted.

The review of three techniques that have been used to minimize energy consumption in wireless sensor networks namely the Cross layer technique, the Sleep Mode Transceiver Technique, and the Hierarchical Routing Technique were discussed. Moreover, we discussed two notable optimization techniques inspired by swarm intelligence – Particle swarm optimization (PSO) and ant colony optimization (ACO) and their application in wireless sensor networks. In the next chapter (Chapter 3), the proposed energy models for this research are presented.



## Chapter 3

### 3 Energy Models for Wireless Sensor Networks

In the previous chapter, a literature review related to the research was presented. The focus areas include a general overview and techniques for energy optimization in wireless sensor networks (WSNs). In this present chapter, a brief discussion of the conventional radio energy model is presented. Thereafter, we present the proposed different energy models for this research.

#### 3.1 Traditional Energy Model

A simple and homogeneous radio energy model was proposed in (Heinzelman et al., 2002) to determine energy consumption in wireless communication. In this model, the transmitter dissipates energy to run the power amplifier and radio electronics while the receiver dissipates energy to run the radio electronics as shown in Figure 3.1.

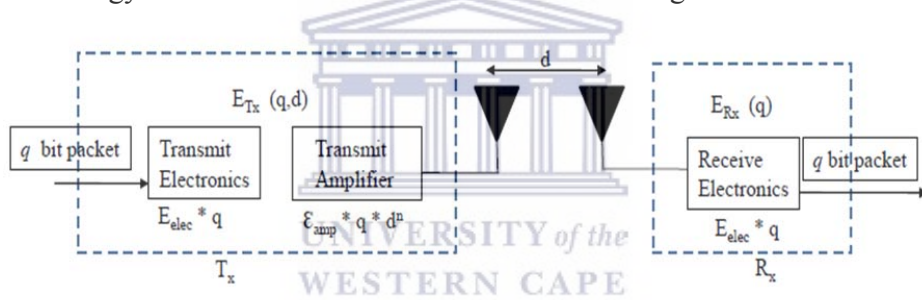

Figure 3.1: Radio energy model (Heinzelman et al., 2002)

This energy model assumed that all sensor nodes transmit the same  $q$  bits of data packets during data transmission ( $Tx$ ) and reception ( $Rx$ ). The traditional energy model is given as follows.

The energy dissipated in Joules by a sensor node to transmit a  $q$  – bit of data packets on a distance of  $d$  meters is expressed by

$$E_{Tx}(q, d) = \begin{cases} q * E_{ele} + q * \epsilon_{fs} * d^2 & \text{if } d \leq d_o \\ q * E_{ele} + q * \epsilon_{amp} * d^4 & \text{if } d > d_o \end{cases} \quad (3.1)$$

and the energy consumed by a sensor node to receive a  $q$  – bit of data packets from a node is given by

$$E_{Rx}(q) = q * E_{ele} \quad (3.2)$$

where  $d_o = \left(\frac{\epsilon_{fs}}{\epsilon_{amp}}\right)^{\frac{1}{2}}$  is a threshold in meters. The electronic energy  $E_{ele}$  depends on factors such as spreading of the signal, modulation, and the digital coding. The Friss free space ( $\epsilon_{fs}$ ) and multi-path ( $\epsilon_{amp}$ ) path loss depends on the transmitter amplifier model while the distance  $d$  between two sensor nodes is determined using the Euclidean distance formula given as follows

$$d_{ij} = \sqrt{(x_i - x_j)^2 + (y_i - y_j)^2} \quad (3.3)$$

The power attenuation of the transmitting sensor node decreases exponentially with the increase in the transmission distance between the sender node and the receiver node.

As presented above, this energy model is based on a simplistic and misleading assumption that all the nodes of any wireless network are assumed to deliver the same service and produce, transmit and receive the same length data packets. Corrective measures need to be applied to such a model when applied to current generation wireless sensor networks which present a high degree of heterogeneity in terms of role, service and capability of the sensor nodes which form the sensor network. When smartly exploited, such heterogeneity can be used to improve energy efficiency and subsequently extend the lifetime of a sensor network. The next subsections present different corrective models to the basic energy model described above.

### 3.2 Service-aware Energy Model

This section presents an improvement on the energy model presented in section 3.1 that differs from the simple traditional energy model in two ways: 1) it is based on the fact that different nodes may be tasked to achieve different services and thus produce (sense), transmit and receive different length data packets ( for each node  $i$  and  $j$ ,  $q_i \neq q_j$  and 2) the role played by a cluster head node (CH) is different from a normal node as it includes services such as data aggregation and fusion and other functions such as allocation of a time division multiple access (TDMA) schedule. This model has been designed to meet the recent advances in wireless technology and image sensors which have enabled the combined use of video and scalar sensors resulting in a new class of wireless sensor

networks called wireless multimedia sensor networks (WMSNs) where a sensor node may have different types of sensors, and generates data of different sizes based on its role in the network.

### 3.2.1 Network model

The newly proposed energy model is based on the following assumptions:

- i. Sensor nodes  $N = \{v_1, v_2, \dots, v_V\}$  are randomly distributed in  $M \times M$  m<sup>2</sup> region and  $V$  is the number of sensor nodes;
- ii. The sensor network is organized into  $K$  number of clusters where each cluster contains a cluster head and member nodes; the cluster head is tasked to collect data from cluster member nodes and fuse this data for transmission to the remote base station. It thus consumes additional energy  $E_F$  for data fusion.
- iii. Energy consumption for data transmission  $E_{Tx}$  and reception  $E_{Rx}$  are equal;

In our proposed energy model, each sender node  $v_i$  transmits  $q_i$  bits data packets to its associated cluster head for  $i \in \{1, \dots, V - K\}$ .

The sensor network is modeled as an undirected graph  $G = (N, L)$ , where  $N = \{v_1, v_2, \dots, v_V\}$  is a set of  $V$  sensor nodes. Each node  $v_i$  has maximum transmission radio range with radius  $r$  meters.  $L$  is a set of two-way edges  $L_{i,j} = (v_i, v_j)$  that links two nodes together such that the nodes  $v_i, v_j \in N$  and  $v_i \neq v_j$ . We assume that two nodes  $v_i$  and  $v_j$  can communicate if they are within the transmission range of each other such that  $d(v_i, v_j) \leq r$ . On the other hand, if the distance between the two nodes is greater than  $r$ , no direct communication between them is possible. The node will transmit through a relay node.

**Round:** A round is defined as an equal period of time (seconds) allocated to the sensor nodes for data transmission and reception. The average number of nodes per cluster is given by:

$$C_k = \frac{V}{K} \quad (3.4)$$

### 3.2.2 Energy model

Suppose the average energy consumption of a cluster head to receive  $q_i$  bits of data from its member nodes and fuse them is  $E_F$  and  $q_k$  bits of data packets are transmitted from cluster heads to the base station for  $k \in \{1, \dots, K\}$ . The energy consumption of a sensor node to transmit  $q_i$  bits of data to the neighbour node is  $E_{Tx} = q_i * E_{ele}$ .

During data transmission the energy consumption of a cluster head in a single round is composed of data receiving, data fusion, and data transmission and is expressed as follows:

$$E_H = (C_k - 1)q_i E_{ele} + C_k q_i E_F + q_k E_{ele} + q_k \epsilon_{amp} d_{toBS}^\alpha \quad (3.5)$$

where  $d_{toBS}$  is the transmission distance from the cluster head to the base station.  $\alpha$  is the transmit amplifier, it is either 2 or 4 depending on the distance of a cluster head from the base station  $i \in \{1, 2, \dots, V - K\}$ ,  $E_{ele}$  Joule is the electronic energy,  $E_F$  Joule is the energy dissipated by the cluster head to fuse the received data.

The energy dissipated by a member node  $E_N$  to transmit  $q_i$  bits of data to its associated cluster head node is given by:

$$E_N = q_i E_{ele} + q_i \epsilon_{fs} d_{toCH}^2 \quad (3.6)$$

where  $d_{toCH}$  is the transmission distance from a sensor node to the cluster head. Taking equations (3.5) and (3.6) together, the energy dissipated in a cluster in a single round is the sum of the energy dissipated by the member nodes and the cluster head expressed as follows:

$$E_{cluster} = (C_k - 1)E_N + E_H \quad (3.7)$$

Equation (3.7) can be simplified as follows:

$$E_{cluster} = 2(C_k - 1)q_i E_{ele} + (C_k - 1)q_i \epsilon_{fs} d_{toCH}^2 + C_k q_i E_F + q_k E_{ele} + q_k \epsilon_{amp} d_{toBS}^\alpha \quad (3.8)$$

The total energy dissipated in a current round is:

$$E_{total} = KE_{cluster} \quad (3.9)$$

The total energy consumption for sensor nodes if the transmission distance  $d$  between the cluster head nodes and the base station is less than or equal to the set threshold distance value  $d_0$  is expressed as follows:



$$E_{total} = 2(V - K)q_i E_{ele} + (V - K)q_i \epsilon_{fs} d_{toCH}^2 + V q_i E_F + K q_k E_{ele} + K q_k \epsilon_{amp} d_{toBS}^2 \quad (3.10)$$

$$d_{toBS} \leq d_0$$

On the other hand, if the distance  $d$  between the cluster heads and the base station is greater than the set threshold distance value  $d_0$  the total energy dissipation is expressed as follows:

$$E_{total} = 2(V - K)q_i E_{ele} + (V - K)q_i \epsilon_{fs} d_{toCH}^2 + V q_i E_F + K q_k E_{ele} + K q_k \epsilon_{amp} d_{toBS}^4 \quad (3.11)$$

$$d_{toBS} > d_0$$

Moreover, the expected average distance between a node and the cluster head is given as:

$$E[d_{CH}^2] = \frac{M^2}{6K} \quad (3.12)$$

Detail of the analytical derivation of the expression (3.12) is contained in section 4.7.

The expression (3.11) can further be expressed as:

$$E_{total} = 2(V - K)q_i E_{ele} + (V - K)q_i \epsilon_{fs} \frac{M^2}{6K} + V q_i E_F + K q_k E_{ele} + K q_k \epsilon_{amp} d_{toBS}^4 \quad (3.13)$$

assuming  $d_{toBS} > d_0$ ,  $M$  is the length (meter) of the network area.

### 3.2.3 Network lifetime

The network lifetime  $t_N$  can be defined as

$$t_N = \frac{\text{sum of the initial energy of all the sensor nodes}}{\text{total energy dissipated in one round}}$$

The network lifetime can be expressed as follows:

$$t_N = \frac{\sum_{i=1}^V E_i}{2(V - K)q_i E_{ele} + (V - K)q_i \epsilon_{fs} \frac{M^2}{6K} + V q_i E_F + K q_k E_{ele} + K q_k \epsilon_{amp} d_{toBS}^4} \quad (3.14)$$

where  $E_i$  is the initial energy of each sensor node. Assuming the base station is located outside the network area.

Average energy  $E_{Avg}$  consumed by the sensor nodes in a round is expressed as follows:

$$E_{Avg} = \frac{E_{total}}{V} \quad (3.15)$$

Expressions (3.10) and (3.11) give sensor nodes' total energy consumption for sensing and transmitting different data packets  $q_i$  at a different time based on different services delivered by each sensor node in the area of interest. This differs from the energy model proposed in (Heinzelman et al., 2002) which assumed all sensor nodes transmit the same  $q$  bits data packets. We consider the same energy parameter values as in the LEACH protocol where  $\epsilon_{amp} = 0.0013 \text{pJ/bit/m}^4$ ,  $E_{ele} = 50 \text{nJ/bit}$ ,  $\epsilon_{fs} = 10 \text{pJ/bit/m}^2$ ,  $E_F = 50 \text{nJ/bit}$ .

### 3.3 Sensor-aware Energy Model

Heterogeneous wireless sensor networks consist of sensor nodes with different sensing capabilities such as different communication range, sensing, processing and computing power. The deployment of a heterogeneous network is more complex compared with homogeneous networks.

#### 3.3.1 Network model

Considering a network  $N = \{v_1, v_2, \dots, v_V\}$  with  $V$  sensor nodes, uniformly distributed within an area  $M * M$  square meters. The set of network consists of two types of nodes: the normal nodes  $N_n$  and the advanced nodes  $N_A$ . Data sensed by the nodes are transmitted to the receiver nodes or a base station located outside the network area.

The following assumptions are made.

- Sensor nodes are uniformly distributed within the network area and they are stationary to avoid frequent topology changes;
- Each cluster contains a cluster head and normal nodes in every round;
- Each sensor node transmits  $q_i$  bits data through a single-hop or multi-hop to its cluster head depending on the number of nodes in a network.
- The base station is located outside the network area, the maximum distance of any node to the base station is greater than threshold distance  $d_0$ .
- Energy dissipated to sense  $E_s$ , to receive  $E_{Rx}$ , and to transmit  $E_{Tx}$  a bit data are equal.

### 3.3.2 Energy model

Let the initial energy of each normal node be represented by  $E_i$  and the energy of advanced node be denoted by  $E_H$ ,  $p$  represents the fraction of the advanced sensor nodes, which is  $h$  times more than the initial energy of the normal nodes. Given the total number of nodes  $V$ , the number of advanced nodes is  $pV$ , and the number of normal nodes is  $(1 - p)V$ , The initial energy of each advanced node is  $E_H = E_i(1 + h)$ .

The total energy of the heterogeneous network is given as

$$E_{total}^H = V(1 - p)E_i + pV(1 + h)E_i \quad (3.16)$$

Equation (3.16) can be simplified as

$$E_{total}^H = V(1 + ph)E_i \quad (3.17)$$

Thus, the total energy of the heterogeneous network is increased by a factor of  $(1 + ph)$ . Since advanced nodes have more energy than the normal nodes, for the current round they are selected as cluster heads and the desired number of cluster heads is chosen from the advanced nodes.

If  $C_k$  represents the average number of nodes per cluster in the network (i.e  $C_k = \frac{V}{K}$ ) where  $K$  is the number of clusters and  $k \in \{1, K\}$ . The value of  $K$  is equal to a fraction of advanced nodes  $p$ . If  $E_N$  denotes the energy dissipated by a sensor node,  $d_{toCH}$  denotes the transmission distance of a sensor node to the cluster head.

The energy dissipated by the normal nodes  $E_N$  in a cluster can be modeled as follows:

$$E_N = (C_k - 1)(q_i E_{ele} + q_i \epsilon_{fs} d_{toCH}^2) \quad (3.18)$$

We assumed that the energy dissipated per bit to run the transmitter or receiver circuit (i.e  $E_{Rx} = E_{Tx} = q_i * E_{ele}$ ),  $q_i$  bits is the data transmitted per node,  $q_k$  bits are the data packets transmitted per cluster head node,  $E_{Tx}$  and  $E_{Rx}$  is the energy dissipated during transmission and reception per bit respectively.  $\epsilon_{fs}$  is the transmitter amplifier which depends on the distance between the nodes,  $C_k$  is the average number of nodes per cluster.

Assuming, the distance from a cluster head to a base station is greater than threshold distance value (i.e  $d_{toBS} > d_0$ ). Energy dissipated by the cluster head  $E_H$  to receive data

from member nodes, fuse the received data and transmits the aggregated data to a base station during a round. The formula is as follows:

$$E_H = (C_k - 1)q_i E_{ele} + C_k q_i E_F + q_k E_{ele} + q_k \epsilon_{amp} d_{toBS}^4 \quad (3.19)$$

The energy dissipated in a cluster is the sum of energy dissipated by the normal nodes and the advanced node in each round by taking equations (3.18) and (3.19) together is given by

$$E_{cluster} = E_N + E_H \quad (3.20)$$

Therefore, the total energy dissipated in the network is expressed as follows

$$E_{total} = K E_{cluster} \quad (3.21)$$

$$E_{total} = 2(V - K)q_i E_{ele} + V q_i E_F + (V - K)q_i \epsilon_{fs} d_{toCH}^2 + K q_k E_{ele} + K q_k \epsilon_{amp} d_{toBS}^4 \quad (3.22)$$

The expected average distance of a node to its cluster head is given as

$$E[d_{toCH}^2] = \frac{M^2}{6K} \quad (3.23)$$

the derivation is contained in section 4.7.

Thus, equation (3.22) can further be expressed as

$$E_{total} = 2(V - K)q_i E_{ele} + V q_i E_F + (V - K)q_i \epsilon_{fs} \frac{M^2}{6K} + K q_k E_{ele} + K q_k \epsilon_{amp} d_{toBS}^4 \quad (3.24)$$

where  $d_{toBS}$  is the expected distance between a cluster head and the base station.

Equations (3.18) and (3.19) show the energy dissipation in both the normal nodes and the advanced nodes in the heterogeneous networks. However, since the networks are composed of nodes with different capabilities (normal nodes and advanced nodes), how much energy should be assigned to these nodes in order to maximize the overall network lifetime? The network lifetime for both the normal nodes and the advanced nodes is determined as follows:

### 3.3.3 Network lifetime

The lifetime of a normal sensor node  $t_N$  is given as follows:

$$t_N = \frac{E_i}{(q_i E_{ele} + q_i \epsilon_{fs} \frac{1}{6K} M^2)(V - K)} \quad (3.25)$$

The lifetime of advanced node  $t_A$  is given as follows

$$t_A = \frac{E_H}{(C_k - 1)q_i E_{ele} + C_k q_i E_F + q_k E_{ele} + q_k \epsilon_{amp} d_{toBS}^4} \quad (3.26)$$

Performance evaluation of these models is presented in chapter 6 of this work.

### 3.4 Load-balancing Energy Model

In the previous section, we proposed energy models for WSNs, deriving expressions for the energy consumed by the cluster head and member nodes in a cluster. While such models present corrective features to the traditional energy model, they fail short to mitigate the energy holes problem that may arise around the base station when the sensor nodes nearer to the base station region receive more data traffic from outer sub-regions. These nodes dissipate higher energy consumption, and are prone to failure and earlier death. After a number of rounds, the nearer nodes die earlier due to the high data traffic received from outer sub-region nodes creating an “energy holes” problem which may results in dysfunction of the whole network. Data transmitted from the outer sub-region will not be able to reach the destination nodes (base station) and affect the lifetime of the entire network.

However, an energy hole problem is inevitable in wireless sensor networks due to the inherent many-to-one data traffic pattern, but it can be minimized (Li et al., 2010).

Our main objective in this section is to derive an analytical model for a uniformly distributed sensor network to mitigate the energy holes problem in order to prolonging the sensor network lifetime.

The model considered here can be used by the backbone of cluster heads to route the aggregated sensor readings from cluster heads to the base station of the network.

#### 3.4.1 Network model

We assume the following points

- i. A set of sensor nodes are uniformly distributed in a circular area of radius R meters;
- ii. Each sensor node has a unique identification number (ID) and static;
- iii. The network is partitioned into  $K$  clusters; denoted by  $G_K$ ;
- iv. The base station is located at the center of the network;
- v. Each node has a maximum transmission range denoted by  $r$ .

Consider a sensor network area with uniformly distributed  $N = \{v_1, v_2, v_3, \dots, v_V\}$  sensor nodes where density  $\rho$  is subdivided into  $y$  concentric circles  $C_0, C_1, C_2, C_3, \dots, C_y$  with base station located at the centre of the network area.

We assume the concentric circles monotonically increasing radii  $r_0 < r_1 < r_2 \dots < r_y = R$  as shown in Figure 3.2. We define  $C_0$  to represent the base station,  $r_y = R$  is the radius of the circle and each sensor node has a maximum transmission range  $r_j$  much smaller than  $R$  i.e ( $r_j \ll R$ ).

The width of sub-circle  $C_j$  is  $r_j - r_{j-1}$ .

However, the width may change as the topology of network changes in each run.

We assume that a sensor node in  $C_j$  uses a transmission radius of  $r_j - r_{j-1}$  to communicate a node in sub-circular area  $C_{j-1}$ .

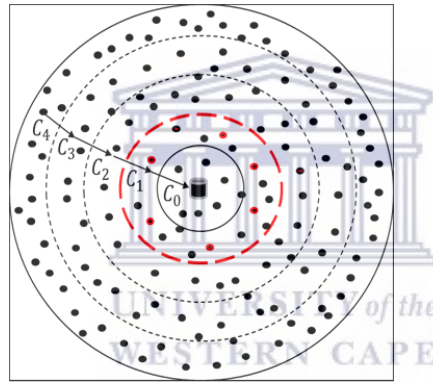

Figure 3.2: Multi-hop data routing in concentric circles of wireless sensor network

### 3.4.2 Energy model

Here we use the energy model presented in section 3.2 to compute the energy consumption of the radio transceiver. We assume the network is divided into  $K$  clusters, each cluster containing a cluster head  $CH$  and  $\left(\frac{V}{K} - 1\right)$  member nodes.

Energy dissipated by each node to transmit  $q_i$  bits data to the cluster head over a distance  $d$  is expressed as follows

$$E_N = q_i E_{ele} + q_i \varepsilon_{fs} d_{toCH}^\alpha \quad (3.27)$$

In a uniformly distributed sensor network, the average distance between a sensor node and its cluster head is given as  $d_{toCH} = \left(\frac{M}{\sqrt{6K}}\right)^\alpha$  (this expression is derived in section 4.7). Replacing the network length  $M$  with the radius  $R$  of the circular shape, the expression (3.27) is given as

$$E_N = q_i E_{ele} + q_i \varepsilon_{fs} \left(\frac{M}{\sqrt{6K}}\right)^\alpha \quad (3.28)$$

where  $E_{ele}$  is the electronic energy consumed by a node to transmit  $q_i$  bits data,  $\varepsilon_{fs}$  is the amplifier energy which depends on the transmitter amplifier model, and  $d_{toCH}$  is the distance from a node to the associated cluster head.

Every cluster head dissipates energy for both intra cluster  $E_{intra}$  and inter cluster  $E_{inter}$ . Thus, the energy consumed by a cluster head in circular  $C_j$  in a given round is expressed as follows

$$E_H(C_j) = E_{intra} + E_{inter}(C_j) \quad (3.29)$$

*Intra-cluster Energy Consumption* ( $E_{intra}$ ): It is the energy dissipated by sensor nodes within a cluster that transmit sensed data to their cluster heads.

*Inter-cluster Energy Consumption* ( $E_{inter}$ ): It is the energy dissipated by cluster heads which transmit the aggregated data to a base station for further processing.

During intra-cluster communication, energy dissipated by the cluster head to receive  $q_i$  bits data from member nodes and fuse them is given by

$$E_{intra} = \left(\frac{V}{K} - 1\right) q_i E_{ele} + \frac{V}{K} q_i E_F \quad (3.30)$$

where  $V$  is the number of nodes in the network,  $K$  is the number of clusters, and  $E_F$  is the energy dissipated by a cluster head node to fuse the received data from its member node. During inter-cluster communication, cluster heads receive data from member nodes, fuse the data, and transmit the aggregated data packets to the base station BS.

Let  $A_1, A_2, A_3, \dots, A_y$  be the area of each concentric circle. Let the width of the concentric circle  $C_j$  be  $r_{j+1} - r_j$  where  $C_0$  denotes the position of a base station. The energy dissipated during inter-cluster communication in each sub-circular is expressed as

$$E_{inter}(C_j) = \frac{\sum_{k=j+1}^y C_k}{C_j} q_i E_{ele} + \frac{\sum_{k=j}^y C_k}{C_j} q_i E_{ele} + \frac{\sum_{k=j}^y C_k}{C_j} q_i \varepsilon_{fs} d_{toC_{j-1}}^\alpha \quad (3.31)$$

where  $j \in \{1, 2, \dots, y\}$  and  $r_j$  is the transmission radius of each circular area  $C_j$ .

When  $j = 1$ , the cluster head in sub-circle  $C_1$  denoted with the red line in Figure 3.2 receives high data traffic from outer concentric circles creating an energy hole.

Assuming the transmission radius required transmitting data from  $C_j$  to  $C_{j-1}$  is  $r_j$ .

Replacing the expression (3.31) with transmission radii  $r$ , the energy dissipation of cluster head in  $C_j$  is expressed as follows

$$E_{inter}(C_j) = \frac{R^2 - r_j^2 - r_{j-1}^2 + R^2 - r_{j-1}^2}{r_j^2 - r_{j-1}^2} q_i E_{ele} + \frac{R^2 - r_{j-1}^2}{r_j^2 - r_{j-1}^2} q_i \varepsilon_{fs} r_j^\alpha \quad (3.32)$$

The energy dissipation for the cluster head located in the prospective energy hole area (i.e.  $C_1$ ) is expressed as follows

$$E_{inter}(C_1) = \frac{2R^2 - r_1^2 - r_0^2}{r_1^2 - r_0^2} q_i E_{ele} + \frac{R^2 - r_0^2}{r_1^2 - r_0^2} q_i \varepsilon_{fs} r_1^\alpha \quad (3.33)$$

Energy dissipation by the cluster head during intra and inter cluster communication in circular area  $C_j$  per round is

$$E_H(C_j) = E_{intra} + E_{inter}(C_j) \quad (3.38)$$

Therefore, the energy consumed by sensor nodes and cluster head in sub-circular area  $C_1$  is given as follows:

$$E(C_1) = K P_1 E_H(C_1) + \left(\frac{V}{K} - 1\right) E_N \quad (3.39)$$

We use  $P_j$  to denote  $\pi$ ,  $P_j = \frac{C_j}{\pi(R^2 - r_0^2)}$  ( $1 \leq j \leq y$ )

$$E(C_1) = K P_1 \left( \frac{2R^2 - r_1^2 - r_0^2}{r_1^2 - r_0^2} q_i E_{ele} + \frac{R^2 - r_0^2}{r_1^2 - r_0^2} q_i \varepsilon_{fs} r_1^\alpha \right) + \left(\frac{V}{K} - 1\right) \left( q_i E_{ele} + q_i \varepsilon_{fs} \left(\frac{M}{\sqrt{6K}}\right)^\alpha \right) \quad (3.40)$$



### 3.4.3 Network lifetime

The lifetime  $t_N$  of sensor nodes can be defined as

$$t_N = \frac{\text{Sum of the initial energy of sensor nodes}}{\text{the energy consumed per round}}$$

Thus, the lifetime of area  $C_1$  can be determined as follows:

$$t_N = \frac{P_1 V E_i}{E(C_1)} \quad (3.41)$$

where  $E_i$  (Joules) is the initial energy of each sensor node in  $C_1$

However, the lifetime  $t_N$  is determined by two parameters: the radius  $r_1$  of circular area  $C_1$  and the number of clusters  $K$ .

To maximize the sensor nodes' lifetime in  $C_1$ , the function  $g(r_1, K)$  should be minimized. For convenience of notation we let  $r_0 = 0$ , equation (3.41) becomes

$$g(r_1, K) = \frac{2R^2}{r_1^2} q_i K E_{ele} - K q_i E_{ele} + K q_i R^2 r_1^{\alpha-2} \varepsilon_{fs} + V q_i \frac{R^\alpha}{(6K)^{\alpha/2}} \varepsilon_{fs} \quad (3.42)$$

Differentiating the expression (3.42) partially with respect to  $r_1$  and partially with  $K$ , we have

$$\frac{\partial g(r_1, K)}{\partial r_1} = \left( (\alpha - 2) R^2 r_1^{\alpha-3} q_i \varepsilon_{fs} - 4 R^2 r_1^{-3} q_i E_{ele} \right) K \quad (3.43)$$

$$\frac{\partial g(r_1, K)}{\partial K} = \frac{(2R^2 - r_1^2)}{r_1^2} q_i E_{ele} + R^2 r_1^{\alpha-2} q_i \varepsilon_{fs} - 3\alpha V R^\alpha (6K)^{\frac{-(\alpha+2)}{2}} q_i \varepsilon_{fs} \quad (3.44)$$

Given the values of  $E_{ele}$ ,  $\varepsilon_{fs}$ , and  $\alpha$ , the function  $g(r_1, K)$  should be minimized so as to maximize the network lifetime  $t_N$ .

However, we can determine the values of  $r_1$  and  $K$  by equating the derivative of the above functions to zero. For  $\alpha > 2$ , the value of  $r_1$  and  $K$  is given as follows:

$$r_1 = \left( \frac{4 * E_{ele}}{(\alpha - 2) \varepsilon_{fs}} \right)^{\frac{1}{\alpha}} \quad \text{for } 2 < \alpha \leq 6 \quad (3.45)$$

$$K = \left( \frac{\alpha V R^\alpha r_1^2 \varepsilon_{fs}}{(4R^2 - 2r_1^2) E_{ele} + 2R^2 r_1^{\alpha-2} \varepsilon_{fs}} \right)^{\frac{2}{\alpha+2}} \quad (3.46)$$

Thus, choosing the value of  $r_1$  and the value of  $K$  correctly can reduce the energy holes among the sensor nodes closer to the base station and hence maximize the lifetime of the entire sensor network.

We evaluate the effectiveness of the proposed energy holes model in chapter 6. Four parameters - number of nodes  $V$ , the radius of the entire network  $R$ , the radius of a concentric circle  $r_j$  and number of cluster heads  $K$  are used to evaluate the lifetime of the sensor network for a given network.

### 3.5 Chapter summary

This chapter provides a brief introduction to the existing radio energy model. We also provided the details for the formulation of three different models proposed and various equations used for the formulations were also given. In the next chapter, (Chapter 4), the proposed protocol architecture, methodology and algorithms are presented.



## Chapter 4

### 4 Energy Optimization using Clustering Techniques

#### 4.1 Introduction

The transmission of data directly from a sensor node to a base station in a large network is not energy efficient due to the long transmission distance that each node might involve. However, more energy savings could be made by partitioning a sensor network into a number of clusters and selecting some nodes with more energy to be cluster heads (CHs) while the remaining nodes remain cluster member nodes as illustrated by Figure 4.1 below where the shaded areas reveal the clusters.

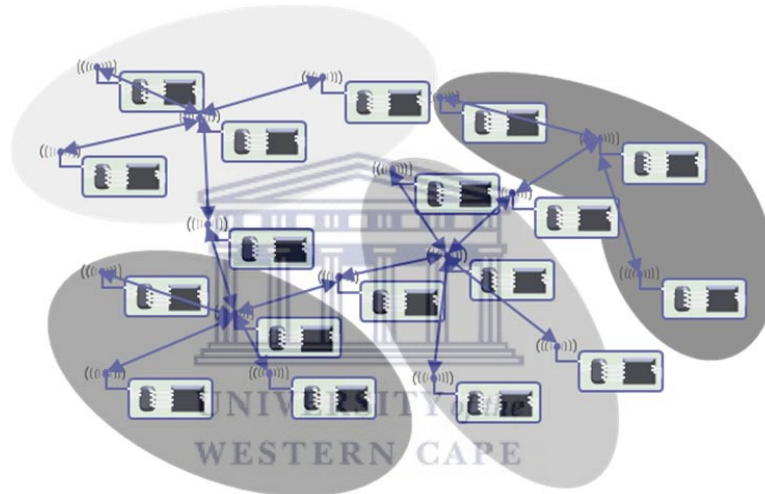

Figure 4.1: Hierarchical clustering of a sensor network (Karl and Willig, 2007)

Such clustering/partitioning of a sensor network is an efficient communication scheme which can improve the sensor network's lifetime and overcome the communication latency problem. This chapter presents the basic ideas behind our clustering protocol which is called Energy Optimization using Clustering Techniques for Wireless Sensor Networks (EOCIT). EOCIT is a protocol that is distributive, dynamic, self-organizing and more energy efficient than some of the previously proposed clustering protocols for WSNs as revealed by our experimental results. Two versions of the proposed protocol using two different schemes are presented in this thesis:

- *Distance-aware clustering* where the cluster heads are selected based on the remaining energy of the sensor nodes and the distance between the nodes.
- *Service-aware clustering* where the cluster heads are selected based on their residual energy and the service to be delivered by the nodes.

The sensor network operation is divided into rounds as described in chapter 3 with each round leading to a new routing configuration where the cluster heads might be different from those selected during the previous rounds. Our work assumes a sensor network topology where 1) a unique and static base station is considered and 2) there is a possibility of creating many clusters which are dynamically changed in each round of the network operation.

Table 4.1 shows the difference between EOCIT and some of the existing clustering protocols used for benchmarking our proposed protocol.

Table 4.1: Uniqueness of the proposed protocol

| <b>Protocol</b> | <b>Cluster head Selection</b>                            | <b>Node Association</b>        |
|-----------------|--|--------------------------------|
| EOCIT           | Distance awareness + Residual energy + Service awareness | Received signal strength (RSS) |
| MOCRN           | Distance awareness                                       | Hop count                      |
| DECSA           | Residual energy  | Distance                       |

Similar to LEACH and other clustering protocols, we consider a hierarchical routing architecture consisting of the three phases shown in Figure 4.2.

- Startup phase*: This phase involves the distribution of sensor nodes into the target area. The sensor nodes can either be uniformly distributed or randomly distributed, depending on the application area to sense changes in the environment.
- Setup phase*: In this phase, the network is divided into finite clusters, each cluster contains a cluster head and member nodes.
- Data Transmission phase*: This phase is also known as steady state. It is the transmission of all sensed data by the sensor nodes to the base station through the cluster heads.

The hierarchical routing model is based on the following assumptions.

- i. The position of each node  $v_i$  is represented by x and y coordinates.
- ii. Two sensor nodes can communicate if they are within the transmission of each other otherwise they communicate through intermediate node.
- iii. Signal strength decreases monotonically as the distance increases between the sender nodes and the receiver nodes.
- iv. Sensor nodes are location aware, that is they know the location of each other and the base station's location.
- v. The base station has powerful hardware and is not constraint with the limited energy.
- vi. Two different sensor network are considered: a) an homogeneous sensor network where all the sensor nodes are homogeneous and are equipped with an Omni-directional antenna and b) a heterogeneous sensor network where the sensor nodes are differentiated between normal and service intensive types and receive a differential treatment such that the - service intensive nodes are assigned cluster member roles while the least service intensive nodes have a higher probability to be selected as cluster heads in the next round.

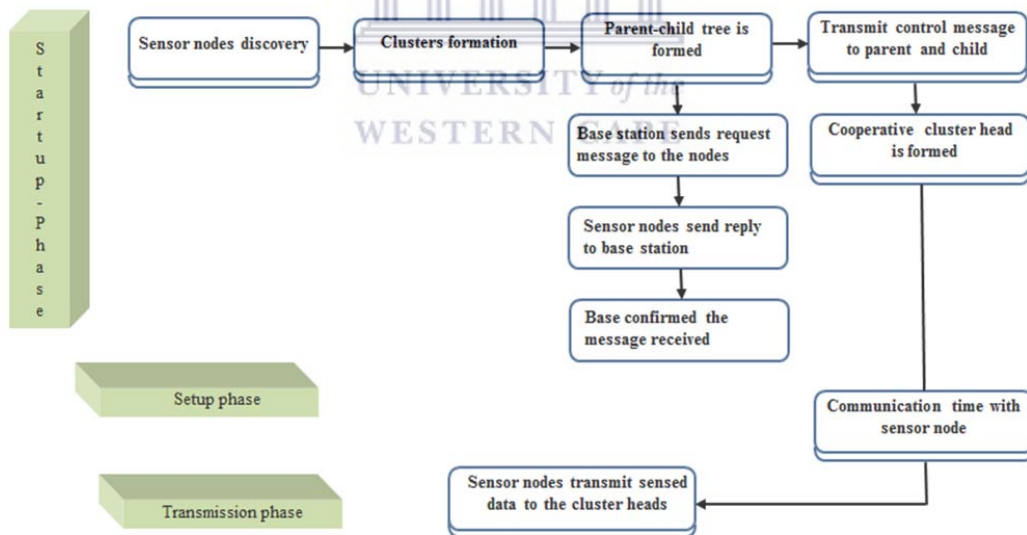

Figure 4.2: Hierarchical routing architecture

## 4.2 Distance-aware Clustering

Using the undirected graph  $G = (N, L)$  presented in section 3.3 and the assumptions made earlier, we consider a homogeneous sensor network using a many-to-one communication model where all sensor nodes generate data traffic and transmit to their cluster heads which fuse the data and transmit it to a base station. Assume  $R(G) = \{R_m\}$  and  $R_m = R_i \cup R_k$  to be the set of routing configuration for the network ( $G$ ), composing the intra cluster routing  $R_i$  and the inter cluster routing  $R_k$ .  $R_i = \{V_i, L_i\}$  is the routing scheme for the sensor nodes where  $V_i$  is the set of sensor nodes and  $L_i$  is the set of links connecting the nodes to their cluster heads.  $R_k = \{V_k, L_k\}$  is the routing scheme for the cluster heads where  $V_k$  is the set of cluster heads and  $L_k$  is the set of links connecting cluster heads to the base station.

If the initial energy of each node  $v_i$  is denoted by  $E_i$ . The residual energy of node  $v_i$  in a cluster  $k$  in a round  $\check{r}$  denoted by  $\check{E}_i(\check{r})$ . The average energy  $\bar{E}_i$  of sensor nodes in cluster  $k$  at the round  $\check{r}$  is given as

$$\bar{E}_i = \frac{1}{C_k} \sum_{i=1}^{C_k} \check{E}_i(\check{r}) \quad (4.1)$$

where  $C_k$  is the average number of nodes in cluster  $k$ , such that  $k \in \{1, K\}$ ,  $K$  is the number of clusters. If a node  $v_i$  is assigned with service delivery  $S(v_i)$ ; the routing configuration  $R_m$  for the sensor nodes can be modelled as follows:

Find  $R_m$   
subject to

$$v_i \in V_k \text{ if } E_k(v_i) \geq \bar{E}_i(\check{r}) \quad (4.2)$$

$$v_i \in V_i \text{ if } E_i(v_i) < \bar{E}_i(\check{r}) \quad (4.3)$$

$$P_r(v_i \in V_k) < P_r(v_j \in V_k) \text{ if } w(v_i) \geq w(v_j) \text{ for all } v_i, v_j \in V \quad (4.4)$$

$$P_r(v_i \in V_i) \geq P_r(v_j \in V_i) \text{ if } w(v_i) < w(v_j) \text{ for all } v_i, v_j \in V \quad (4.5)$$

where  $w(v_i)$  is the weight of node  $v_i$  with regard to its distance to the base station. Equations (4.2) and (4.3) are energy aware constraints where the least energy dissipated sensor nodes have a higher probability to be selected as cluster heads in the next round while the most energy dissipated nodes in the current round become member nodes. Equations (4.4) and (4.5) express distance-aware constraints where the least weight nodes

(longer average distance from the base station) have a higher probability to become cluster heads while the highest weight nodes are selected to become cluster member nodes.

### 4.3 Selection of Cluster heads Phase

Clustering is a process by which a sensor network is divided into finite clusters where each cluster contains a cluster head and non-cluster head nodes.

Thus, being a cluster head node (CH) consumes much more energy than normal nodes because of extra functions which they perform such as data aggregation and re-transmission of received data to the next CH or base station. It is imperative to rotate the position of cluster head for uniform energy distribution so that some nodes will not run out of energy earlier than other nodes in a network. Therefore, the algorithm for the formation of clusters should be designed such that energy consumption will be uniformly distributed among the nodes.

#### 4.3.1 Cluster heads Selection Process

Given  $V$  sensor nodes randomly distributed in a network area  $A = M \times M \text{ m}^2$ .

Assuming the base station located outside the network area.

During initialization, all sensor nodes send their information to the base station; the information includes their coordinates ( $x$  and  $y$  position), identification numbers (ID), initial energy, residual energy, and the respective sensor node's distance to the base station.

The base station receives the information from the nodes and stores it for subsequent use.

Based on the sensor nodes' energy information received, the base station uses the information to calculate the network's average energy  $\bar{E}_t$  as shown in equation (4.1).

Having determined the network's average energy, the next step is the selection of cluster heads (CHs). Base station compares the current energy of the individual node with the average energy computed, if the energy of a node is more than the average energy computed, the node is selected as a CH candidate for the current round.

In the first round, almost all the nodes qualify to be selected as CHs since they have an equal amount of initial energy. The description below is used to select CHs that are well distributed in the network among many qualified sensor nodes.

First, the distance  $d$  of each node to the base station  $B$  located outside the network at the coordinate  $d(B_x, B_y)$  is computed and stored at the base station.

Thereafter, the network area is temporarily partitioned into  $K$  clusters using Algorithm 1; the diagram for the cluster formation is shown in Figure 4.3.

EOCIT uses distance information as a weight function  $W$ . The closer a node is to the base station, the higher the weight and the farther a node is from the base station, the smaller the weight. In each temporary cluster  $G_k(T)$  formed, a node with the smallest weight represented by a square shape is selected as a temporary cluster head  $CH_k^T$  as shown in the figure. Then the sum of the distances between the nodes and  $CH_k^T$  is computed using the Euclidean distance formula in equation (3.3) and divided by the number of nodes in each temporary cluster to get the average distance  $\bar{D}$  expressed as follows

$$\bar{D} = \frac{1}{C_k} \sum_{i=1}^{C_k} d_i \quad (4.6)$$

where  $d_i$  is the coordinate of sensor nodes, and  $C_k$  is the average number of nodes per temporary cluster. A node with the average distance is selected as the main cluster head. In case the position of a node is not the same as the value of  $\bar{D}$ , a node in which its coordinate value is or nearest to the  $\bar{D}$  is selected as a cluster head for the current round. However, if two nodes have the same average value, a node is selected as a cluster head (CH). The same process is used for the selection of other cluster heads until the desired CHs have been selected and the algorithm ends. The main reason behind this method is to ensure the selected CHs are uniformly distributed within the network unlike CBER and LEACH-CE protocols (Mammu et al., 2013; Tripathi et al., 2013) in which the cluster heads are selected based on probability. In these protocols, the selected CHs may be on the same side of the network and nodes that are far away will use more energy to transmit to their CHs and more energy is consumed.

Once the CHs selection has been concluded, the new CHs broadcast their new status to all nodes in the network and cluster formation follows. Process for cluster formation is presented in section 4.5. The uniqueness of this method is that each cluster head selected during the initial round is at the center of the cluster formed and each cluster has nearly an equal number of member nodes as shown in Figure 4.4.



However, if the current energy of a CH is below a set threshold energy  $E_T$  value (i.e  $E_H < E_T$  ), then the CH ceases to be a CH and becomes a normal node. A new CH is selected for the next round as described below. In our experiments the threshold energy is set to 45% of CH initial energy.

---

**Algorithm 1:** Temporary Cluster Formation and selection of cluster heads

---

**Begin**

```

1: Given a set of  $N = \{v_1, v_2, \dots, v_V\}$  sensor nodes
   randomly distributed into an  $M \times M$  meter square area;
2: initialize individual sensor nodes;
3: Input  $K$ ; %  $K$  is the desired number of clusters
4: for  $k = 1: K$ 
5:    $x(k) = \text{rand}(1,1) * V$ 
6:    $y(k) = \text{rand}(1,1) * V$ 
7: end
8: voronoi ( $x, y$ )
9:  $V_K = \bigcup_{k=1}^K G_k, K < V$ ; %  $G_k$  is a cluster
10:  $G_k \neq \emptyset; k \in \{1, K\}$ ;
11:  $l = 1$ ;
12: while  $K - l > 1$  do
13: select
14:  $G_k, G_{k+1} \in V_{K-l+1}$ ;
15:  $V_{K-l} = (V_{K-l+1} \setminus \{G_k, G_{k+1}\})$ ;
16:  $l = l + 1$ ;
17: end while
18: assign weight to each node  $v_i$  per temporary cluster
   formed based on the distance to the base station.
   The longer the distance between a node and the base
   station the smaller the weight.
19: for  $i = 1$  to  $C_k$  %  $C_k$  denotes number of nodes
   per cluster
20: if  $v_i, G_k =$  smallest weight then
21:  $v_i.\text{type} = CH_k^T$  % temporary cluster head in cluster k
22: else  $v_i.\text{type} = v_i$  %  $v_i$  is a normal node
23: for  $k = 1: K$ 
24:  $\frac{1}{C_k} \sum_{i=1}^{C_k} d(v_i, CH_k^T)$ 
25: end for
26: end for
27:  $v_i.\text{type} = CH_k$  % select the real cluster heads

```

**End**

---

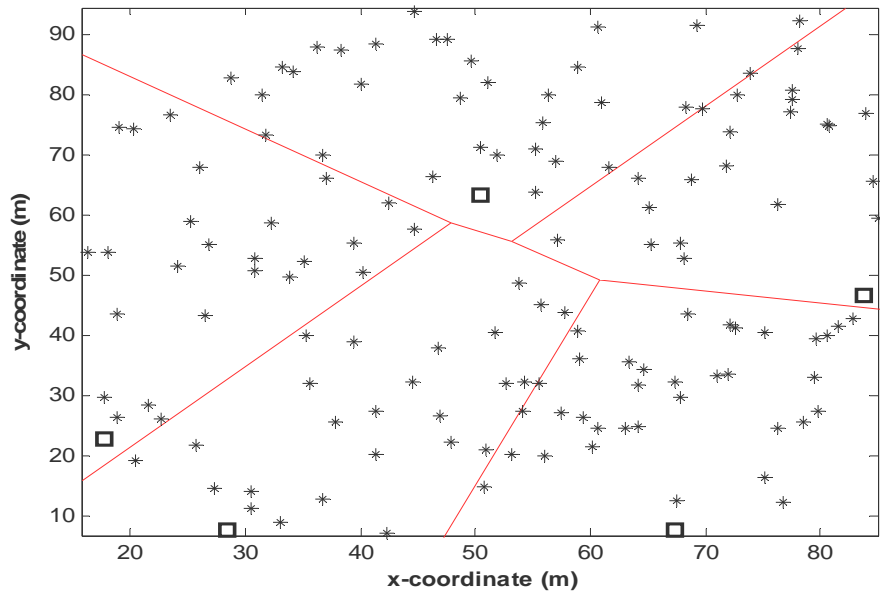

Figure 4.3 : Temporary cluster formation

### Subsequent cluster heads selection based on energy awareness

Energy consumption of the sensor nodes during communication is an important parameter defining the sensor nodes' network lifetime. Cluster heads dissipate much more energy than non-cluster head nodes after a number of rounds due to the extra functions which they perform. If sensor nodes remain as cluster heads (CHs) for a long period, their energy levels decrease and they cease to be the cluster heads. Energy levels of these nodes should be taken into consideration. The energy consumption of the sensor nodes should be distributed through a periodic rotation of cluster heads among the eligible sensor nodes in order to increase the network lifetime. To take account of these, we considered two parameters that increase the probability of selecting a node as the next cluster head as expressed in equation (4.7).

- i. The energy level (residual energy) of the sensor nodes in a cluster;
- ii. Distances between the nodes and their cluster heads.

These two parameters increase the probability  $P_r$  of a node  $v_i$  to be selected as a cluster head node  $CH_k$  for the next round of the cluster head selection expressed as follows:

$$P_r = \alpha * y_1 + \beta * y_2 \quad (4.7)$$

$$y_1 = \frac{\sum_{i=1}^V E(v_i)}{\sum_{k=1}^K E(CH_k)} \quad (4.8)$$

$$y_2 = \max_{k \in \{1,2,\dots,K\}} \left\{ \sum_{v_i \in C_k} \frac{(d(v_i, CH_k))}{C_k} \right\} \quad (4.9)$$

where  $y_1$  is the fraction of total initial energy of all sensor nodes  $V$  in the network over the total current energy of the qualify cluster head candidates and  $y_2$  is the maximum average Euclidean distance of eligible sensor nodes to their connected cluster heads.  $V$  is the total number of nodes and  $K$  is the desired cluster heads, and  $C_k$  is the number of nodes in cluster  $G_k$  for  $k = \{1,2, \dots, K\}$ .  $\alpha$  and  $\beta$  are constants used to weight the contribution of the energy factor and communication distance,  $\alpha + \beta = 1$  (Kulkarni and Venayagamoorthy, 2011)

Algorithm 1 is used for the initial cluster heads selection when all the nodes in the network start with the same initial energy. Algorithm 2 is used for the cluster formation and subsequent selection of cluster heads. The two parameters introduced above enable the base station to determine the qualification of individual sensor node  $v_i$  to be selected as a cluster head provided the distance of a node to the  $CH_k$  is the smallest distance compared to other all cluster heads. Similarly, only sensor nodes whose energy is above the average energy are selected as the cluster head candidates. Sensor nodes that satisfy these two conditions will be selected as the next cluster heads.

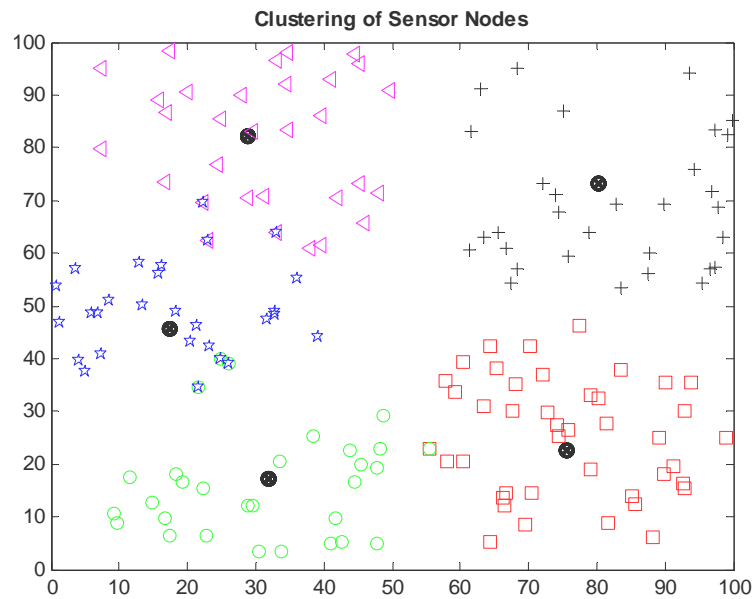

Figure 4.4: EOCIT dynamic cluster formation process

Moreover, sensor nodes that have not been cluster heads recently usually have more residual energy than nodes that have been previously selected as cluster heads (Jing and Aida, 2010).

Given that the initial energy of each node is  $E_i$ .

If a node has been a cluster head previously, its residual energy is approximately  $\tilde{E}_i = E_i - E_H$ , where  $E_H$  is the cluster head energy dissipated and usually less than  $E_i$ . However, if the energy of a cluster head is less than set threshold value  $E_T$ , the node will cease to be a CH and a node that satisfied the two conditions mentioned above will become a new cluster head. The EOCIT flowchart for Cluster Formation is shown in Figure 4.6.

---

---

**Algorithm 2:** Cluster Formation and Selection of Subsequent Cluster Heads

---

---

**Begin**

- 1: % this algorithm is used to select the next round of the cluster heads
- 2: Input  $K$ ; %  $K$  is the desired number of cluster heads
- 3:  $C_k = \frac{V}{K}$ ; %  $C_k$  is the average number of nodes per cluster
- 4: Compute  $d(v_i, CH_k)$  between node  $v_i$  and all selected cluster heads  $CH_k$ ;
- 5: Assign each node  $v_i$  to  $CH_k$  such that  $d(v_i, CH_k) < r$ ;  
%  $r$  is the maximum transmission range of each node
- 6: **if** number of nodes in a cluster  $G_k$  equals  $C_k$  **then**
- 7:      $G_{k+1}$ ;
- 8: **end if**;
- 9: **if**  $CH_k$ .energy  $< E_T$ ; %  $E_T$  is the cluster head threshold energy
- 10:     Compute the average energy of sensor nodes  $V$  using equation (4.8) ;
- 11:     Calculate the maximum average Euclidean distance of eligible sensor nodes to their associated cluster heads using equation (4.9);
- 12:     Compute the fitness function of eligible node to be selected as cluster head using equation (4.7);
- 13:     Assign each node  $v_i$  to  $CH_k$
- 14:      $\sum_{v_i \in C_k} \frac{d(v_i, CH_k)}{|C_{v_i, k}|}$ ; % each node belongs to the closest cluster head,  $CH_k$  and
- 15:      $V \leftarrow \bigcup_{k=1}^K C_k$ ; % All nodes are assigned to the clusters.
- 16: **end if**
- 17: repeat steps 9 to 17 until the maximum number of iteration is reached

**End**

---

---

#### 4.4 Service-aware Clustering

Recent improvement in wireless technologies has enabled the design of low-cost hardware, and tiny audio and image sensors creating a new class of networks called wireless multimedia sensor networks (WMSNs). These networks are made up of normal nodes and more advanced nodes (hybrid nodes) which are tasked to achieved different services and thus handle different sizes of data packets at different times. These different nodes are assigned different roles based on the service they are expected to deliver (Yaghmaee and Adjero, 2009).

In this scheme, individual sensor nodes are assigned roles based on their service delivery with service intensive nodes being preferentially assigned member node roles while the least service intensive nodes in the current rounds are preferentially selected as cluster

heads. A typical application of such models is a scenario where hybrid nodes are deployed in a smart parking system to achieve car localization (RF reader) and parking spot localization (sensor) at the booth where normal sensor nodes are tasked to only sense a presence on parking spots. In such a scenario, the hybrid nodes are assumed to be tasked with higher service delivery than the normal sensor nodes. Thus, new cluster heads are elected based on the sensor nodes service delivery. To the best of our knowledge, no previous research has been done on clustering by selecting cluster heads based on service differentiation. However, work that is similar to ours is found in (Agarkhed et al., 2012). The authors divided the networks into different clusters with many base stations; firstly to minimize the energy consumption at each sensor node. Secondly, it increases the manageability of the network. Cluster heads are selected using Dijkstra's Least Delay routing algorithm. On the other hand, our work considered only a single base station for data collection.

We consider sensor networks consisting of different types of sensor nodes that sense different types of data in the area of interest. These include (a) normal sensor nodes (*SN*), Hybrid sensor nodes (*HSN*), gateway nodes (*GN*), and a base station (*BS*).

The major function of normal nodes is to sense data in their environment and periodically transmits sensed data to their cluster heads.

Hybrid nodes combine the sensing and reading of multimedia data such as video and audio data.

Gateways nodes interconnect multiple clusters and perform network communication.

The base station is a data collection center and is connected to the gateway nodes.

Table 4.2 illustrates the mapping of sensor nodes service delivery into their roles played in the networks.

Table 4.2: Mapping sensor nodes service delivery into routing roles

| Sensor type<br>$x$ | Service delivery<br>$S(x)$ | Routing role: $(V_i, V_k)$ | Energy (Joule) |
|--------------------|----------------------------|----------------------------|----------------|
| SN                 | Sensing                    | Member node, cluster head  | 1              |
| HSN                | Sensing + reading          | Cluster head, member node  | 1.5            |
| GN                 | Reading                    | Relay data                 | 2              |

However, the service delivery in this network needs to be energy efficient. Energy consumption of the nodes depends on the service delivery. The network is divided into  $K$  clusters using Algorithm 2. We made a little modification to the algorithm by assigning the normal nodes and the hybrid nodes different energy. The hybrid nodes are assigned with more energy due to the role they play in the network in combining the sensing and reading of data.

#### 4.4.1 The Service-aware Clustering Problem

Using the undirected graph  $G = (N, L)$  presented in section 3.3 and the assumptions, we consider many-to-one routing model where sensor nodes generate the data traffic and transmit to the cluster heads.

Assume  $R(G) = \{R_m\}$  and  $R_m = R_i \cup R_k$  be the set of routing configuration for the network ( $G$ ), composed of intra cluster routing  $R_i$  and inter cluster routing  $R_k$ .  $R_i = \{V_i, L_i\}$  is the routing scheme for the sensor nodes where  $V_i$  is the set of sensor nodes and  $L_i$  is the set of links connecting the nodes to their cluster heads.

$R_k = \{V_k, L_k\}$  is the routing scheme for the cluster heads where  $V_k$  is the set of cluster heads and  $L_k$  is the set of links connecting cluster heads to the base station as shown in Figure 4.5.

If the initial energy of each node  $v_i$  is denoted by  $E_i$ , the residual energy of node  $v_i$  in a cluster  $k$  at the round  $\check{r}$  is denoted by  $\check{E}_i(\check{r})$ . The average energy  $\bar{E}_i$  of sensor nodes in cluster  $k$  at the round  $r$  is given as

$$\bar{E}_i = \frac{1}{C_k} \sum_{i=1}^{C_k} \check{E}_i(\check{r}) \quad (4.10)$$

where  $C_k$  is the number of nodes in cluster  $k$ , such that  $k \in \{1, K\}$ ,  $K$  is the number of clusters and  $\bar{E}_i(\check{r})$  is the average energy of sensor nodes in cluster  $k$ . If a node  $y$  is assigned with service delivery  $S(y)$ ; the routing configuration  $R_m$  for the sensor nodes can be modelled as follows

Find  $R_m$   
subject to  
 $y \in V_k$  if  $E_k(y) \geq \bar{E}_i(\check{r})$  (4.11)

$y \in V_i$  if  $E_i(y) < \bar{E}_i(\check{r})$  (4.12)

$P_r(y \in V_k) < P_r(z \in V_k)$  if  $S(y) \geq S(z)$  for all  $y, z \in V$  (4.13)

$P_r(y \in V_i) \geq P_r(z \in V_i)$  if  $S(y) < S(z)$  for all  $y, z \in V$  (4.14)

Equations (4.11) and (4.12) are energy aware constraints where the least energy dissipated sensor nodes have a higher probability to be selected as cluster heads in the next round while the most energy dissipated nodes in the current round become member nodes as discussed in section 4.2.

On the other hand, equations (4.13) and (4.14) explain the service differentiation enabling the sensor nodes to be assigned different roles depending on their service types.

It is better to use a deployment scenario to explain this: normal nodes sense a presence in a parking lot while hybrid nodes are equipped with the possibility of sensing and reading tags if deployed unattended using batteries, the hybrid nodes should firstly deplete their energy before the normal nodes. This is due to the multiple services they provided.

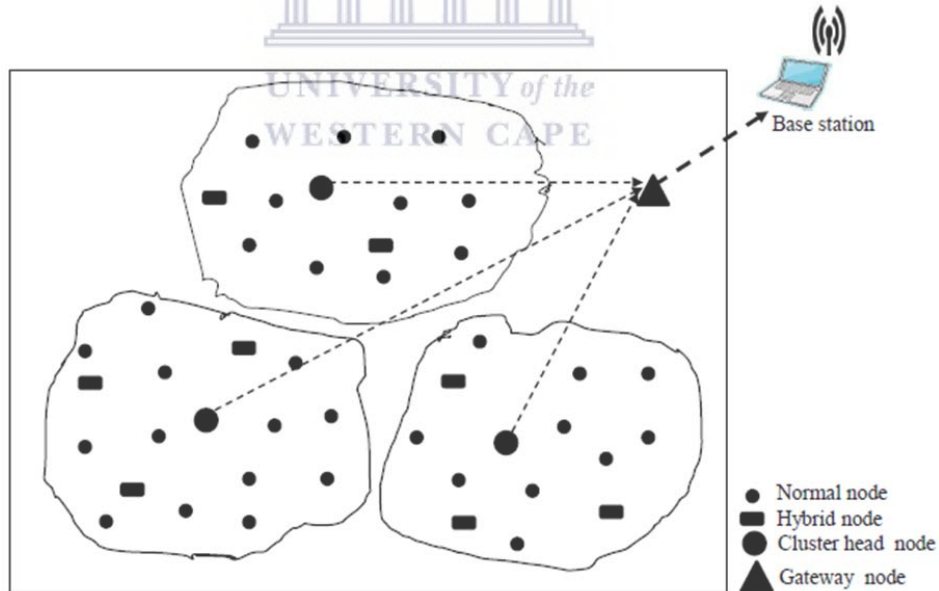
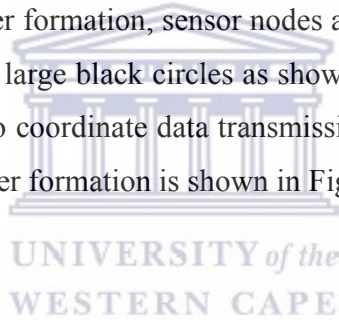

Figure 4.5: Sensor nodes clustering based on service differentiation



#### 4.5 Formation of Clusters Phase

Once the desired number of cluster heads has been selected for the current round, cluster heads send an advertisement message (ADV) to all nodes in the network using the non-persistent Code Sense Multiple Access (CSMA) MAC protocol (Sen et al., 2012) to make member nodes aware of their current status and their locations. The ADV message contains a header and the ID of each cluster head (CH). In our proposed protocol the cluster heads are well distributed within the network based on our discussion in section 4.3 therefore, all sensor nodes can receive the ADV message sent by the cluster heads. A non-cluster head node determines the cluster it is to join by selecting a cluster head that is within its radio range in which the *received signal strength* (RSS) of the advertisement message received from each cluster head is strongest. However, if there is an obstacle in-between the two physically close nodes such as a building, a tree, or a big object; a node will select another cluster head that is further away but more energy efficient in terms of communication. In our cluster formation, sensor nodes are denoted by small circles and the cluster heads are denoted by large black circles as shown in Figure 4.4. Every cluster head acts as a local base station to coordinate data transmission in its cluster. The flowchart for the EOCIT hierarchical cluster formation is shown in Figure 4.6.



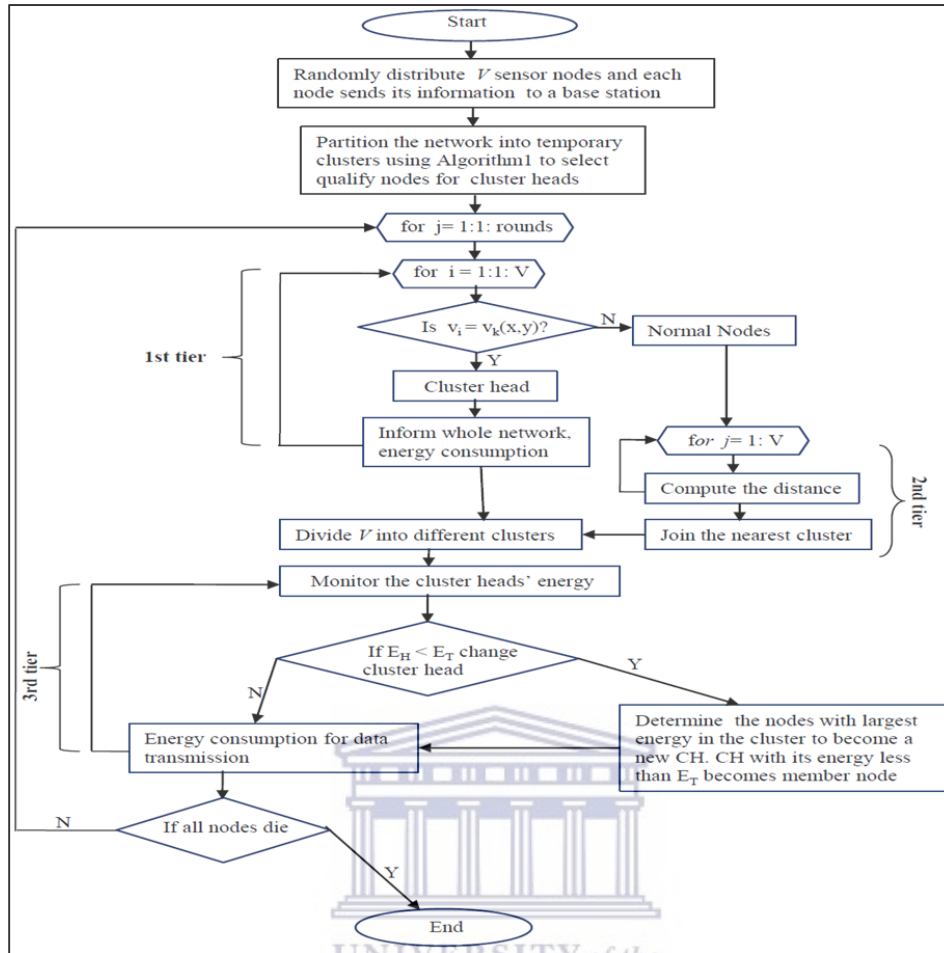

Figure 4.6: Flowchart for EOCIT hierarchical cluster formation

### Multi-hop routing

One basic characteristic of wireless sensor network applications is to transmit sensed data between the sensor nodes and the base station. This usually requires transmission of data packets through multi-hop particularly for a large network using relay nodes to reduce the communication distance among the sensor nodes in order to achieve energy efficiency.

### Selecting a Relay Node

Given a set  $N = \{v_1, v_2, \dots, v_V\}$  of  $V$  sensor nodes randomly distributed in a  $M \times M$  sensor area. If  $r > 0$  is the maximum transmission range of each node and  $R$  is the communication range of a relay node  $v_k$ , then let  $d(v_i, v_j)$  denotes the Euclidean distance between nodes  $v_i$  and  $v_j$ . Sensor node  $v_i$  transmits directly to node  $v_j$  if  $d(v_i, v_j) \leq r$ .

However, if the communication distance between nodes  $v_i$  and  $v_j$  is greater than  $r$ , then  $v_i$  transmits through a relay node.

Thus, below two conditions must be satisfied for a node to be selected as a relay node.

Firstly, the node must be closer to a cluster head in its cluster and must be within the transmission range of a sender node  $v_i$ .

Secondly, the relay node must have energy which is higher than the set reference energy to receive and retransmit the data.

We set the reference energy of a relay node candidate to 40% of its initial energy. If the potential relay node does not satisfy the two conditions mentioned above, then the next node in the hop that meets the requirement will be selected as a relay node. Thus, node  $v_i$  selects node  $v_k$  as a relay node if it satisfies the two conditions and is expressed as follows

$$d_{ij}^2 + d_{jk}^2 < d_{ik}^2 \quad (4.15)$$

where  $d_{ij}$ ,  $d_{jk}$  and  $d_{ik}$  are the distance between the nodes using the Euclidean distance formula stated in equation (3.3) (Xiao et al., 2010).

The essence of relay nodes is to minimize communication distance between the nodes particularly, in a large network.

#### 4.6 Data Transmission phase

The data transmission phase is also known as the steady-state phase. It is the transmission of all sensed data by the nodes to the base station via the cluster heads. Sensor nodes transmit to their cluster heads during their allocated time slot using time division multiple access (TDMA). A sensor node senses  $q_i$  bits of data and transmits to its cluster head (CH). The CH receives data from the member nodes in its cluster. It processes  $\sum_{i=1}^{C_k} q_i$  bits of data and transmits the processed  $q_k$  bits of data packets to the base station. In this phase, member nodes transmit sensed data to their CHs either through the single hop or multi-hop depending on the network size. The operation of sensor node transmission is shown in Figure 4.7.

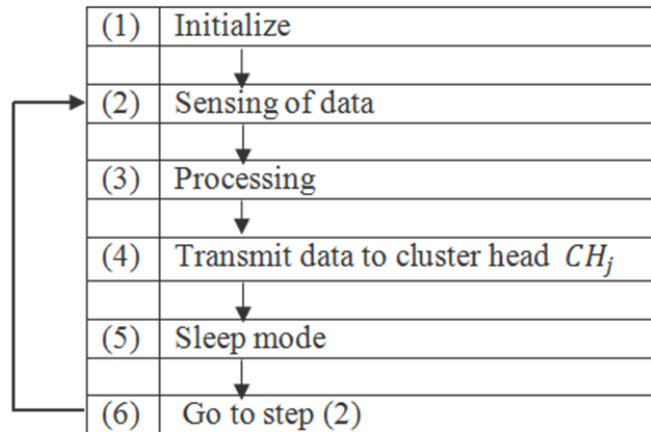

Figure 4.7: Operation of sensor node transmission

However, a node goes into sleep mode after it has transmitted its data to the corresponding cluster head or through the relay node. This research adopted the asynchronous sleep-wake scheduling scheme during data transmission.

#### 4.6.1 Asynchronous sleep-wake scheduling scheme

Sleep-wake scheduling is an aspect of energy conservation that enables sensor nodes to enter sleep mode when not transmitting or receiving any data in a given round; the radio transceiver of sensor node is turned off (Kuo et al., 2012). However, in asynchronous wake-up scheduling, each node with sleep-wake scheduling enters into sleep mode and turns off its radio circuitry for a period of  $T_{sleep}$  and then wakes up for a period of  $T_{wake}$ . This approach enables each node to independently transmit data without collision and does not require global clock synchronization. Moreover, the radio circuitry of sensor nodes in idle mode is divided into sleep, sensor, active states, and transmission states.

*Sleep state:* If a sensor node has no data to transmit, it goes into sleep state and sets a timer  $T_{sleep}$  scheduling a period at which it will enter a sensor state.

*Sensor state:* A node in sensor state sets a timer  $T_{wake}$  scheduling a time at which it will enter the sleeping state. It remains in sensor state until its allocated time expires.

Incidentally, a node detects an event or receives a request-to-send (RTS) message from member nodes; it switches from sensor state to active state and increments its buffer by one unit. It starts the handshaking by sending RTS packets to the receiver node. The receiver

node then acknowledges with a clear-to-send (CTS) packet. Once the sender node receives a CTS message, it goes into transmission state and begins to transmit to the receiver node. In this state, all components of node are turned on and are fully functional. In a situation where the buffer is empty before the wake-up time expires; the node automatically goes to sensor state. Conversely, if the buffer is not empty and the wake-up time has expired, the sensor node returns to wait state. This enables the node to send all sensed data in its buffer before it goes to sensor state.

*Wait state:* The wait state is similar to active state except that sensor node cannot detect or receive new data in this state. It returns to sleep state when its buffer is empty. This approach ensures that only a sensor node can transmit data that time. The node returns to active state after it has finished transmitting its data and the timer is expired, otherwise it goes to a wait state until it completes its transmission and goes to sleep state. The state transition diagram is shown in Figure 4.8.

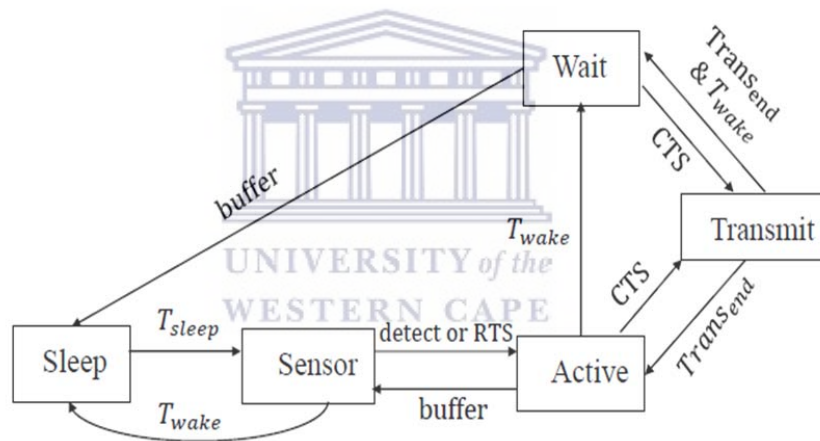

Figure 4.8: State transition diagram of a sensor node

A sensor node operation lifetime can be divided into many rounds and each round is divided into frames as shown in Figure 4.9. The steps above are performed by a sensor node in each round. The algorithm for the data transmission (steady-state) phase is contained in Algorithm 3.

Once every node has selected the minimum energy cost as its relay node an intra-cluster route begins. A non-cluster head node joins the nearest CH based on the received signal strength (RSS). In a situation where the distance between transmitting node and the CH is more than maximum transmission range  $r$ , the node transmits through a relay node.

The relay node receives all data from other nodes within its range; it adds its own data and aggregates the data into the data packets. The aggregated data is transmitted to the CH. Once each cluster head has received all the data from member nodes in its cluster, it removes all redundant data through pre-processing and transmits the processed data to the base station for further analysis.

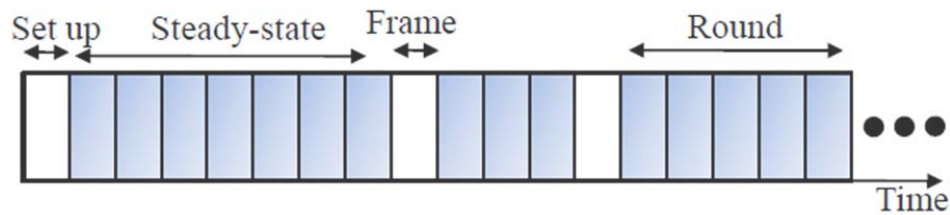

Figure 4.9: The operating cycle in clustering methods (Heinzelman et al., 2002)

*Transmission Slots:* After clusters have been formed, the base station sets-up a time slot for each node to transmit messages within each cluster using time division multiple access (TDMA) (Mehta et al., 2012). Moreover, each sensor node is assigned periodically an epoch (timeslot), during which it is permitted to take charge of the wireless medium and transmit its data. This ensures there are no collisions during data transmission among the nodes.

A timeslot consists of a control period and a data transmission period. In the control period, sensor nodes send control information prior to the data transmission. The control period contains the following information: source node ID, receiver's node ID, current slot, hops length, and acknowledgement (ACK). The data transmission period is when nodes gain control of the network medium and transmit to the cluster head.

Timeslots are a fixed number of time intervals contained in a frame (Incel et al., 2011). Sensor nodes keep track of the number of data packets they receive during communication. In this work, we adopted the multi-channel medium access control (MuchMAC) parameters (Borms et al., 2010) in which the node radio is turned off (sleep interval) for 500ms when not transmitting any data and wakes-up every 5ms to sense its environment and to check if there is any new data to sense. Figure 4.10 shows different modes of a sensor node in wireless sensor networks. Thus, after transmission the nodes turn-off their radio transceivers and enter into sleep mode to save energy until their allocated time expires or there is new data to sense.

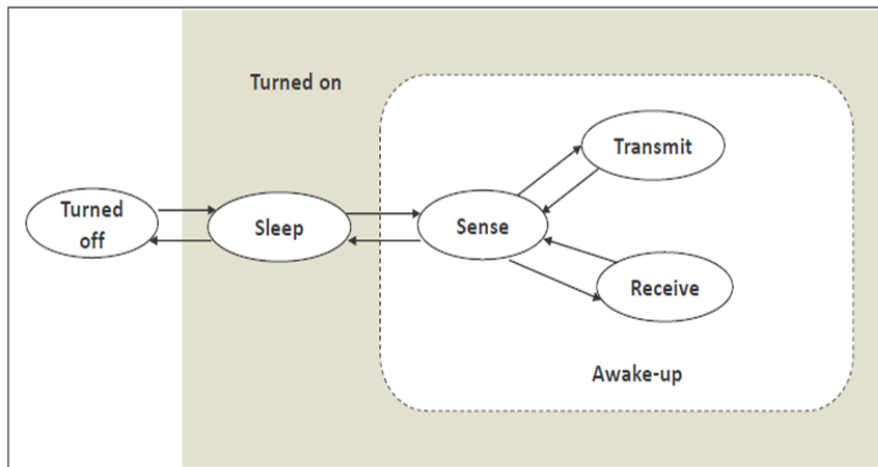

Figure 4.10: Different modes of a sensor node in wireless sensor networks.

---



---

**Algorithm 3:** Steady- state Phase

---



---

**Begin**

```

1: for each frame  $f$  in round  $R$  do
2:   for each cluster member node  $n_i$  do
3:     if  $v_i.Timeslot = \text{TRUE}$  then
4:       Transmit data to the cluster head  $CH_k$ 
5:     else
6:        $v_i.SleepMode = \text{TRUE}$ ;
7:     end if
8:   end for
9:   if  $CH_k.Timeslot = \text{TRUE}$  then
10:    Transmit the aggregated data to the base
    station
11:   end if
12: end for

```

**End**

---



---

#### 4.6.2 Data Aggregation for Sensor Nodes

This section explains the importance of processed data over unprocessed data. Sensed data is processed through the removal of similar data and data aggregate the data. Data aggregation has emerged as a simple rule in wireless sensor networks (WSNs) to reduce the size of data transmitted. The main idea is to collect data from different sensor nodes and perform pre-processing on the received data into a single packet. It can be performed locally at the cluster heads and globally at the base station. The processed data provide a

meaningful and useful description of events of the area in which the sensor nodes are deployed. Data aggregation performed locally at the cluster heads minimizes the total energy consumption in the network and improves network bandwidth utilization since less data are transmitted to the base station.

In a largely deployed sensor network, there is a high possibility for sensor nodes to sense the same event with similar readings. Therefore, it is necessary to fuse the data before transmitting to the base station. For each cluster in a network, there is at least one cluster head; the cluster head computes the median,  $mdn$  value of all sensed data in its cluster and compares with  $q_i$  bits of data sensed by the individual sensor node  $v_i$ . It removes all those data with significant difference and name it blacklisted  $T_c$ . Thereafter, the cluster head node determines the mean value  $\bar{x}_N$  of the remaining data in the cluster and transmits it to the cluster head (Ngai et al., 2006). The algorithm for data aggregation is presented in Algorithm 4.

In the case of unprocessed data, sensed data are transmitted directly to the base station without any preprocessing at the intermediate nodes.

---



---

**Algorithm 4:** Data Aggregation for Sensor Node

---



---

**Begin**

```

1: Define  $\bar{x}_N$  as fused data mean of cluster  $G_k$ ;
2: for each sensor node  $v_j$  receive data  $v_i$  do
3:   if multiple  $v_i \in G_k$  and  $v_j$  is the cluster head node then
4:     compute the median  $mdn$ , among cluster nodes
5:     for each data  $v_i \in G_k$  do
6:       if  $v_i - mdn > T_c$  then
7:         blacklist node  $i$ 
8:       end if
9:     end for
10:     $\bar{x}_N =$  mean of the unblacklisted data  $v_i \in G_k$ 
11:   end if
12: end for

```

**End**

---



---

We analytically compare the energy dissipation needed to transmit unprocessed data to a base station and energy dissipation needed to perform local data aggregation and transmit the fused data to the base station. Assuming that the energy dissipation to fuse  $q_i$  bits of data is  $E_F$  and to transmit the data to the base station is  $E_{Tx}$ . Suppose the ratio at which the data aggregation process compresses the data is ratio  $q_i$  to one (i.e.  $q_i:1$ ). This means for



every  $q_i$  – bit of data that must be transmitted to the base station when no data fusion is performed, only one bit of data must be sent to the base station when the data is fused. Thus, the energy required to perform data fusion and send the fused data for every  $q_i$  – bit of data is given by

$$E_F = q_i * E_F + E_{Tx} \quad (4.16)$$

where  $E_F$  is the total energy dissipation to fuse  $q_i$  – bit of data and transmits to the base station through distance  $d$ .

Conversely, energy required to send all  $q_i$  bits of data directly to the base station without process is given by

$$E'_F = q_i * E_{Tx} \quad (4.17)$$

However, fusing sensed data within the cluster requires less energy than transmitting all the unprocessed data directly to the base station when

$$E_F < E'_F \quad (4.18)$$

$$q_i * E_F + E_{Tx} < q_i * E_{Tx} \quad (4.19)$$

$$E_F < \frac{(q_i - 1)E_{Tx}}{q_i} \quad (4.20)$$

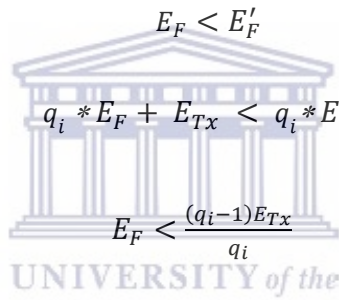

To confirm the expressions in (4.17) and (4.18), we ran simulation on 25 sensor nodes. The sensor nodes transmit data to the cluster head, fuse the data and transmit the single data packet to the base station located at (50, 175) m from the centre of the sensor network of 100m x 100m. On the other hand, all of the unprocessed data are transmitted directly to the base station. The energy cost to transmit a unit of data to the base station is 50μJ/bit/signal,  $E_F = 50$ nJ,  $E_{Tx} = 50$ nJ/bit,  $M=100$ , packet size  $q_i$  is 4000 bits. Figure 4.11 shows the total energy dissipated in the network when the cluster head performed preprocessing and transmitted the fused data to the base station (indicated as “Data Aggregation”) versus the total energy dissipated in the network without preprocessing. Data transmitted directly to the base station is indicated as “Direct Transmission”. We varied the energy used by the cluster head to perform data aggregation from 1pJ/bit/signal ( $10^{-12}$ J/bit/signal) to 1mJ/bit/signal ( $10^{-3}$ J/bit/signal). If the energy used for data aggregation is less than  $10^{-5}$ J

indicated with the arrow then it is more energy efficient to perform data preprocessing locally by the cluster head before transmitting to the base station.

Conversely, if the energy cost of aggregating the data is higher than  $10^{-5}$ J, it is more energy efficient to transmit the data directly to the base station.

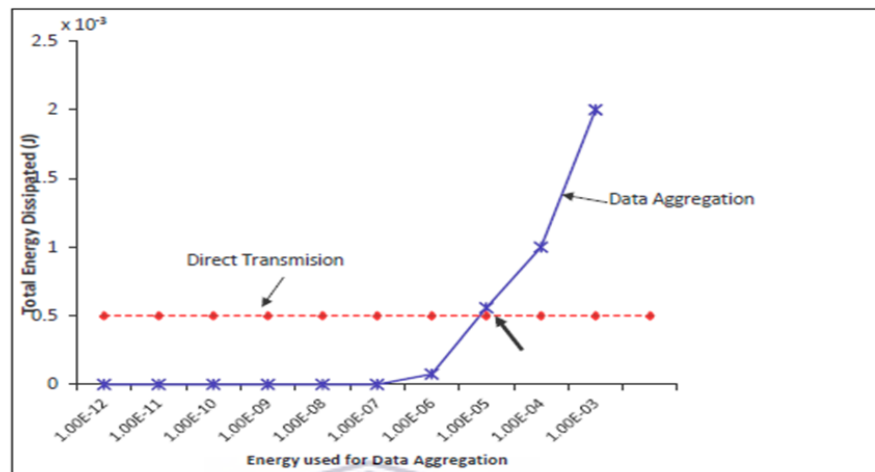

Figure 4.11: Energy dissipation to perform local data aggregation and direct transmission to the base station

#### 4.7 Determining the Optimal Number of Clusters

In sensor networks, too few or too many of the clusters will cause energy waste, affecting the lifetime of the networks sustainability. It is desirable to have optimal number of clusters in a network in order to minimize sensor node energy consumption and maximizing the lifetime of the sensor networks.

An optimal cluster can be defined as the one size such that transmitting data from the source nodes to their cluster heads and successively to base station incurs minimal communication overhead.

Given that  $V$  sensor nodes are randomly distributed in an  $M \times M$  square area network having  $K$  number of clusters. A question could be asked, how should we determine the optimal value of clusters that will minimize sensor nodes' energy consumption in a network?

In most clustering algorithms, the number of clusters  $K$  in a network are usually predefined and based on some assumptions (Haque and Yoshida, 2012; D. Kumar et al., 2011).

We analytically derive a formula to compute the optimal value of  $K$  for a given number of sensor nodes in a network using the proposed energy model in section 3.2. The optimal value of  $K$  derived by our method can be used to guide the implementation of the clustering algorithms that need such information.

Using the above information, the average number of nodes per cluster is  $C_k = \frac{V}{K}$ .

Assuming a cluster contains only one cluster head, each cluster contains a cluster head and  $\frac{V}{K} - 1$  member nodes. If the length of the network is  $M$  meters, the expected area covered

by each cluster head is  $\frac{M^2}{K}$  based on Voronoi tessellation and the area covered by the cluster heads (CHs) in the whole networks using an approach similar to (Gu et al., 2010) is given

as  $\sqrt{\frac{M^2}{K}} * \sqrt{\frac{M^2}{K}}$  square meters.

The following were assumed

- A cluster contains one cluster head and member nodes.
- Sensor nodes are uniformly distributed over the square area. We acknowledge that the area covered by the CHs may not be square shaped.

Moreover, to determine the expected distances between sensor nodes and their CH, the location of each sensor node is denoted by  $(x_i, y_i)$ . The location of the CH inside each cluster is denoted by  $(x_{CH}, y_{CH})$ . The area covered by each cluster in a square area is

$\sqrt{\frac{M^2}{K}} * \sqrt{\frac{M^2}{K}}$  with a node distribution  $\partial(x, y)$ . The expected squared distance from the sensor

nodes to the cluster head assumed to be at the centre of the network using Burgers' equation (Yeo et al., 2010) and integrating over the domain  $[0, M]$  is expressed as follows

$$E[d_{toCH}^2] = d[(x_i, x_j), (y_i, y_j)] = \int_{\theta=0}^M \int_{\theta=0}^M (x^2 + y^2) \partial(x, y) dx dy \quad (4.21)$$

where  $(x^2 + y^2)$  is the coordinate distance between two nodes,  $\partial(x, y)$ ,  $0 \leq x, y \leq M$ , is the joint probability distribution function for the sensor nodes.

However, for non-partitioned sensor nodes,  $\partial(x, y) = \frac{1}{M^2}$ , we have

$$E[d_{toCH}^2] = \frac{1}{M^2} \int_{\theta=0}^M \int_{\theta=0}^M (x - \frac{M}{2})^2 + (y - \frac{M}{2})^2 dx dy \quad (4.22)$$

For  $K > 1$ , integrating with respect to  $x$  and  $y$

$$E[d_{toCH}^2] = \frac{K}{M^2} \left( \int_{\theta=0}^{\frac{M}{\sqrt{K}}} \int_{\theta=0}^{\frac{M}{\sqrt{K}}} \left( x - \frac{M}{2\sqrt{K}} \right)^2 + \left( y - \frac{M}{2\sqrt{K}} \right)^2 \right) dx dy \quad (4.23)$$

The expected average distance between a node and a cluster head (CH) is given as follows

$$E[d_{toCH}^2] = \frac{M^2}{6K} \quad (4.24)$$

The energy consumed in a cluster consists of the energy consumed by the cluster head  $E_H$  and the member nodes  $E_N$  in a given round expressed as follows

$$E_{cluster} = E_H + (C_k - 1)E_N \quad (4.25)$$

The total energy consumed in the whole network is

$$E_{total} = KE_{cluster} \quad (4.26)$$

The expression (4.26) is the total energy cost,  $E_{total}$  for sensor nodes to transmit a bit of data to their respective cluster heads.

Let  $E_F$  be the energy dissipation for aggregating 1 bit of data packets.

$$E_{total} = 2(V - K)E_{ele} + (V - K)\epsilon_{fs} \frac{M^2}{6K} + VE_F + KE_{ele} + K\epsilon_{amp}d_{toBS}^4 \quad (4.27)$$

The optimal number of clusters is determined by letting the derivative of  $E_{total}$  with respect to  $K$  in equation (4.27) to zero, we have

$$K^2 = \frac{V\epsilon_{fs} M^2}{6\epsilon_{amp} d_{toBS}^4} \quad (4.28)$$

$$K_{opt} = \sqrt{\frac{V\epsilon_{fs} M^2}{6\epsilon_{amp} d_{toBS}^4}} \quad (4.29)$$

Therefore, the value of  $K_{opt}$  in the expression (4.29) is the optimal number of clusters for our energy model. The value will be compared with findings obtained from previous energy models developed for an optimal number of clusters.

## 4.8 Topology Analysis

The distribution of sensor nodes can either be uniformly distributed or randomly distributed depending on the applications area. Each distribution is explained below.

### 4.8.1 Uniform Distribution of Sensor Nodes

If the area to be covered is easily accessible, sensor nodes can be uniformly arranged within the network area. This will enable the best possible coverage and easier clustering of sensor nodes. To cover a particular area  $D$ , assuming that the transmission distance between node  $v_i$  and node  $v_j$  is  $r$  in all the cases. If each subarea can be covered by two or more sensor nodes, some sensor nodes that are not transmitting or receiving any data are allowed to go into the sleep state to conserve energy. The coverage area of every sensor node and the total number of nodes required per coverage area for four different shapes namely: triangular, circle, rectangular, and hexagonal clusters are given in Table 4.3 (Zhang et al., 2009).

Table 4.3: Area covered by each node and total required number of sensor nodes

| Network shape | Distance between any adjacent nodes | Area covered by each node      | Total number of nodes required per coverage area   |
|---------------|-------------------------------------|--------------------------------|--|
| Triangular    | $r$                                 | $\frac{\sqrt{3}}{4} r^2$       | $\left\lceil \frac{4D}{\sqrt{3}r^2} \right\rceil$  |
| Circle        | $r$                                 | $\frac{C_i}{\pi(r^2 - r_0^2)}$ | $\pi r^2$  |
| Rectangular   | $r$                                 | $R^2$                          | $\left\lceil \frac{D}{r^2} \right\rceil$           |
| Hexagonal     | $r$                                 | $\frac{3\sqrt{3}}{4} r^2$      | $\left\lceil \frac{4D}{3\sqrt{3}r^2} \right\rceil$ |

The layout of sensor nodes for uniform distribution in a rectangular shape is shown in Figure 4.12. The nodes are placed at equal distance from each other in a square formation; each node can have a maximum of eight neighbours arranged around them assuming the base station is at the centre of the network. Sensor nodes in this network form expanding layers from the centre, the inner most layer could be one or more hops from the base station, depending on the size of the network. The network assumes the worst case data routing in the sense that each sensor node is only attached to the next layer to and from the

base station. This implies that all data sent to the base station have to pass through the next layer that is nearer to the base station as shown in the figure.

If  $V$  sensor nodes are uniformly distributed over an area  $D$ , the sensor node density is  $\lambda = \frac{V}{D}$ . The probability that there are  $m$  nodes ( $m \in V$ ) covered the area  $Q$  is Poisson distributed and can be expressed as follows

$$P(m) = \frac{(\lambda Q)^m}{m!} e^{-\lambda Q} \quad (4.30)$$

The probability that the area being monitored has one node can be expressed as

$$P(m) = 1 - P(0) = 1 - e^{-\lambda Q} \quad (4.31)$$

However, the probability that there are least  $v_k$  nodes deployed to communicate together in a given area  $D$  is expressed as follows

$$P_{v_k} = 1 - \sum_{m=0}^{v_k-1} P(m) = 1 - \frac{(\lambda D)^m}{m!} e^{-\lambda D} \quad (4.32)$$

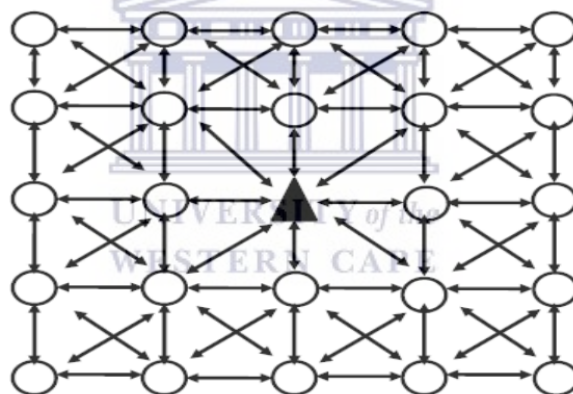

Figure 4.12: Network layout of uniform sensor nodes distribution

#### 4.8.2 Random Distribution of Sensor Nodes

Uniform distribution of sensor nodes in a wireless sensor network can save more energy than random distribution; the reason is that each node transmits its data through an equal distance. However, it may not be practically feasible in some sensor network applications, particularly in a large network or harsh environments that are not accessible to human beings such as a military battle field, to uniformly place the nodes. In such environments, sensor nodes have to be placed randomly in the target area from where they will transmit

their sensed data to the data centre (base station) and where it will be processed and analyzed to produce useful information to the end users. The nodes may be air borne as shown in Figure 4.13 or distributed by any other suitable methods.

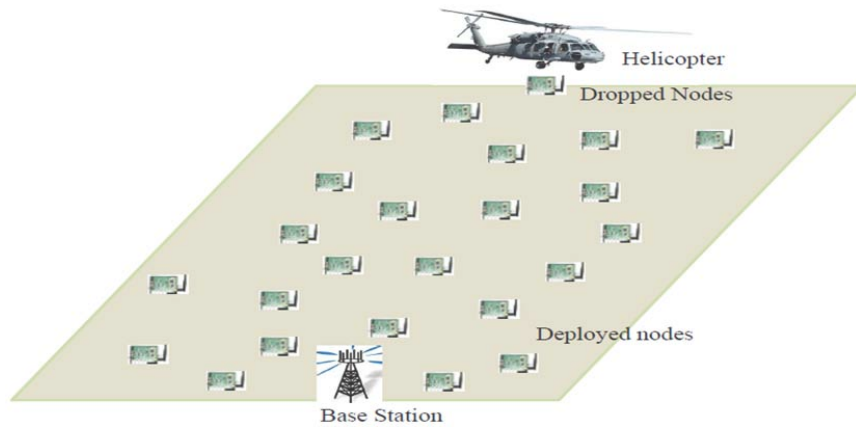

Figure 4.13: Random deployment of sensor nodes

#### 4.9 Maximizing the Sensor Network's Lifetime

In this section, the optimization based formulation for the wireless sensor networks is presented. Data sensed in the target area by sensor networks need to be sent to a base station through intermediate nodes. In these networks, an individual node is capable of sensing, performs pre-processing, and transmits using the small battery energy dissipated mostly during communication at its radio transceiver. We assume that the sender nodes have the ability to adjust their power level to match the transmission distance. The energy dissipation rate during communication depends on the selected receiver nodes.

The routing problem in wireless sensor network is formulated as a linear programming to address the problem of maximizing the lifetime of wireless sensor networks based on some constraints.

We model the network as an undirected graph  $G = (N, L)$  where  $N$  denotes the set of all sensor nodes in the network and  $L$  denotes the set of links connecting the sensor nodes.

The initial energy of each node be represented by  $E_i$  Joules and the rate at which data is generated from node  $v_i$  by  $Q_i$  bits and the energy needed to transmit  $q_i$  bits of data from node  $v_i$  to neighbour node  $v_j$  is to be denoted by  $E_{Tx}$ .

Let  $A$  be the set of target areas to be monitored and  $B_i$  denote the subset of  $A$  in the range of sensor  $v_i$ ,  $i \in \{1, 2, \dots, V - K\}$ .

Let  $\{G_1, G_2, \dots, G_K\}$  be disjoint partitions (clusters) of the set of  $V$  sensor nodes such that  $\cup_{j \in G_k} B_j = A$ , for  $k \in \{1, 2, \dots, K\}$  assuming the number of sensor nodes in each cluster  $G_k$  covers all the target areas. The aim is to transmit data packets in an efficient way such that the sensor network lifetime is maximized.

The linear programming formulation is similar to (Yun and Xia, 2010; Zhao and Yang, 2012), but different in the sense that - we include some constraints such as the lower and upper bounds constraints, and the residual energy constraint into our formulation.

We first explain the following terms.

*Sensor Network Lifetime:* We define the lifetime of a sensor network as the time when the first node or a certain percentage of sensor nodes in a network run out of power and its energy is equal to zero. It is the earliest time at which some nodes in the network cease to cover their target area (Maraiya et al., 2011). In other words, it can be defined as the time span which enables sensor nodes to transmit and deliver the maximum amount of data to the base station. However, a specific definition of sensor network lifetime is application dependent.

*Sensor Node Remaining Lifetime:* The remaining lifetime of each sensor can be defined as the remaining normalized energy of the sensor after a given period of time. It is the total energy of all nodes minus the energy dissipated by the nodes during a single round.

We considered the energy consumption of sensor nodes during transmission ( $E_{Tx}$ ) and reception ( $E_{Rx}$ ) in the formulation of our model since radio is the major energy consumption of sensor nodes.

*Flow Conservation:* The sum of the data packets received from member nodes by a sensor node and the amount of data generated by the node is equal to the amount of data packets sent by the sensor node. The model is presented as follows.

Let the initial energy of each node be represented by  $E_i$  and the rate at which data is generated from node  $i$  by  $Q_i$  bits and data packets transmitted from node  $v_i$  to the neighbor node  $v_j$  be denoted by  $q_{ij}$ .



Using the conservation of flow condition which states that at sensor node  $v_i$  the sum of all incoming flow data plus the rate at which information is generated at node  $v_i$  is equal to the outgoing data flow, is expressed as follows

$$\sum_{j:i \in N_j} q_{ji} + Q_i = \sum_{m \in N_i} q_{im}, \quad (4.33)$$

where  $N_i$  denotes the neighbours of node  $v_i$ ,  $N_j$  denotes the neighbours of node  $v_j$ ,  $m$  contains in  $N_i$  ( i.e  $m \in N_i$  ) and  $L$  is the link between node  $v_i$  and neighbour node  $v_j$ .

Moreover, the energy consumed at node  $v_i$  to receive a unit of data from other nodes is denoted by  $E_{Rx}(i)$ . Similarly, energy consumed at node  $v_i$  to transmit data to the next node is  $E_{Tx}(i)$ . The total energy consumed at node  $v_i$  during communication is represented by  $E^T(i)$ . The energy dissipation at sensor node  $i$  to receive sensed data is expressed by

$$E_{Rx}(i) = \sum_{j:i \in N_j} q_{ji} E_{ele} \quad (4.34)$$

where  $E_{ele}$  is the radio energy dissipation. The energy dissipation at node  $v_i$  to transmit to node  $m$  at distance  $d$  meters is expressed as follows

$$E_{Tx}(i) = \sum_{m \in N_i} q_{im} (E_{ele} + \epsilon_{fs} d_{im}^2) \quad (4.35)$$

where  $\epsilon_{fs}$  is the transmission amplifier energy dissipation,  $d$  is the distance between the source node  $v_i$  and the receiver node  $m$ . The total energy consumed by the node  $v_i$  is the sum of energy dissipated for reception and transmission and is expressed as follows

$$E_{total} = \sum_{j:i \in N_j} q_{ji} E_{ele} + \sum_{m \in N_i} q_{im} (E_{ele} + \epsilon_{fs} d_{im}^2) \quad (4.36)$$

The sensor node lifetime is denoted by  $t_N$  and given as

$$t_N = \frac{E_i}{\sum_{j:i \in N_j} q_{ji} E_{ele} + \sum_{m \in N_i} q_{im} (E_{ele} + \epsilon_{fs} d_{im}^2)} \quad (4.37)$$

$$\left( \sum_{j:i \in N_j} q_{ji} E_{ele} + \sum_{m \in N_i} q_{im} (E_{ele} + \epsilon_{fs} d_{im}^2) \right) t_N \leq E_i \quad i \in V \quad (4.38)$$

where  $E_i$  is the starting energy of each node. Constraint (4.38) shows that the total energy dissipated by all nodes during transmission and reception cannot exceed the total initial energy in a round.

Moreover, we determine the network sensor lifetime ( $L$ ) by minimizing the lifetime of all sensor nodes in expression (4.37) as follows

$$t_L = \min_{i \in V} t_N \quad (4.39)$$

To prevent a sensor node transmitting beyond its limit, we imposed flow bound constraints which include lower and upper bounds, into the problem to regulate the amount of data at node  $v_i$  transmitting to node  $v_j$  as  $0 \leq q_{ij} \leq q_{ij}^{max}$ , where  $q_{ij}^{max}$  is the maximum possible rate at which data can be sent from node  $v_i$  to node  $v_j$ .

Using the expression for a system lifetime in (4.39), the lifetime of the whole network can be maximized as follows

$$\text{Max } t_L \quad (4.40)$$

The above equations can be formulated into linear programming. Let  $\bar{q}_{ij}$  represents the amount data sent from sensor node  $v_i$  to sensor node  $v_j$  at time  $t$  seconds (i.e  $\bar{q}_{ij} = q_{ij} * t$ ). Thus, equations (4.33), (4.37), and (4.40) are as follows

Objective: Maximize the network lifetime:

---

$$\begin{aligned} & \text{Maximize } t_L & (4.41) \\ & \text{subject to} \end{aligned}$$

$$0 \leq \bar{q}_{ij} \leq \bar{q}_{ij}^{max} \text{ for all } i, j \in V \quad (4.42)$$

$$\sum_{j: i \in N_j} E_{Rx} \bar{q}_{ij} + \sum_{m \in N_i} E_{Tx} \bar{q}_{im} \leq E_i \text{ for all } i \in V \quad (4.43)$$

$$\sum_{j: i \in N_j} \bar{q}_{ji} + Q_i t = \sum_{m \in N_i} \bar{q}_{im} \text{ for all } i \in V \quad (4.44)$$

---

$$t \geq 0 \quad (4.45)$$

---

The objective function (4.41) maximizes network lifetime through the minimization of energy consumption of each sensor node in the network. The constraint (4.42) represents the rate of information flow in a node. It places the lower bound and upper bound on the rate of data packets transmitted. It ensures that a node does not transmit or receive data packets beyond its capacity. The constraint (4.43) ensures that the total amount of energy consumed during transmission and reception at each node  $v_i$  cannot be greater than the initial battery energy  $E_i$  of that node. The constraint (4.44) ensures that the amount of incoming data transfer rates and data generating at sensor node  $v_i$  is equal to the total

outgoing data transfer rates from the sensor node to the neighbor node or base station as shown in Figure 4.14. The constraint in (4.45) enforces the non-negativity of time  $t$  seconds.

Evaluation of this model will be tested in chapter six and will compare its performance with previously proposed models.

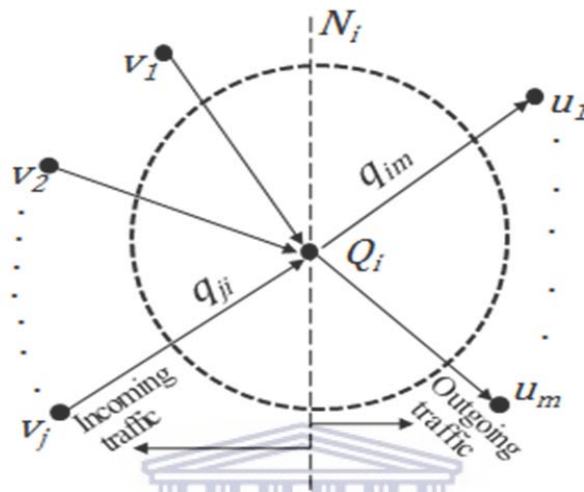

Figure 4.14: Flow conservation condition

#### 4.10 Chapter Summary

This chapter has presented the proposed novel cluster-based routing protocol scheme for energy optimization in wireless sensor networks. Different algorithms were developed to achieve the main objective. The first algorithm is used to select temporary cluster heads that leads to the selection of the main cluster heads. The second algorithm is used for the formation of clusters. The algorithm considered three parameters for the cluster formation - energy aware cluster-based scheme, distance based scheme, and service differentiation.

In this chapter, mapping of sensor nodes service delivery into their roles played in the network was also discussed.

We derived formula for an optimal number of clusters to avoid too few or too many clusters for a given network to further minimize energy consumption.

Finally, we formulate linear programming to maximize the lifetime of wireless sensor network based on some constraints.

The next chapter presents multipath routing ant colony optimization to construct optimal paths between the source nodes and the base station.

## Chapter 5

### 5 Multipath Routing protocol using Ant Colony Optimization

#### 5.1 Introduction

Similarly to cluster-based sensor networks, a hierarchical network can be organized into a backbone-based network where the sensor network is organized into a multi-layer network and a set of more powerful nodes forming the network backbone are used as transit for other nodes to transmit their sensor readings to the gateway. Such backbone nodes usually form a (minimal) dominating set connecting all the nodes of the sensor network as illustrated by Figure 5.1 below where the shaded area reveals the backbone connecting all the other nodes. In both clustering and backbone-based networks, the network of cluster heads and backbone nodes is usually a data intensive network which is tasked to transport most of the sensor network traffic coming from different sources to the sink of the network. Both types of hierarchical networks require efficient methods/techniques for routing the aggregate traffic collected from the cluster heads/backbone nodes to the base station.

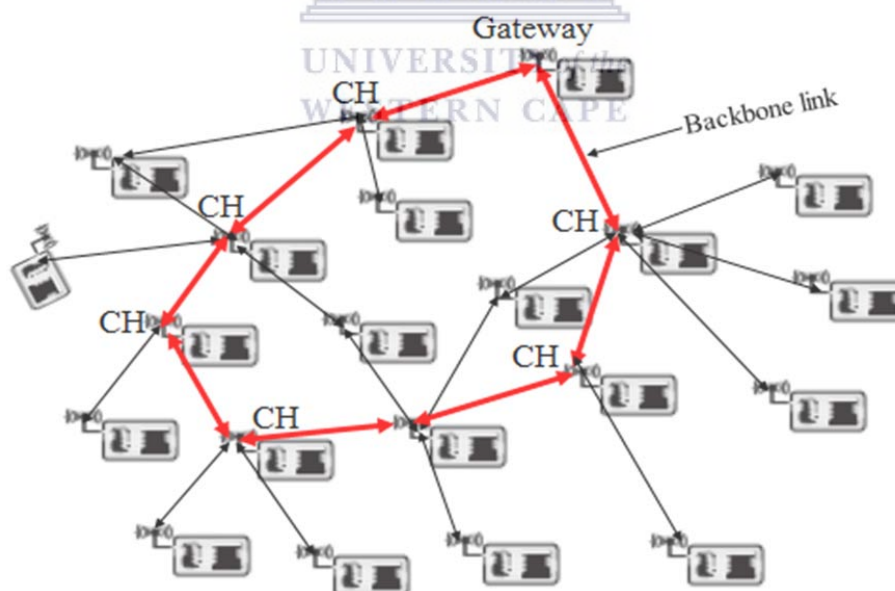

Figure 5.1: Backbone sensor network adapted from (Karl and Willig, 2007)

Multipath routing provides the potential to increase the likelihood of reliable data delivery of information from source to destination by sending multiple copies of the same data along different paths (Bagula, 2010; Dulman et al., 2003; Estrin et al., 2002; Ganesan et al., 2001). It can also increase the throughput of a network by sending different pieces of the information in parallel over different paths and restoring the entire information at the destination with the expectation of achieving better playback delay (the maximum delay taken by all the pieces of information to arrive to the destination) and minimized on-time packet delivery. Many multipath routing techniques have been proposed to improve reliability by setting up disjoint paths in the sensor network. However, although they have the same attractive resilience properties, disjoint paths (node-disjoint paths) can be energy inefficient since the alternate node-disjoint path can be longer and therefore expends significantly more energy than that expended on the primary path. Braided multi-path routing techniques have been proposed to relax the requirement for node disjointedness with the expectation of addressing the energy issues of node disjoint paths (Y. Yang et al., 2010). However, these techniques are still built around reliability requirements, discounting the energy and throughput requirements of cluster- and backbone-based sensor networks. Owing to their structure, efficiently designed Ant Colony Optimization (ACO) techniques provide the potential to achieve more efficient multipath routing techniques.

### **5.1.1 Ant Colony Optimization**

Ant colony optimization (ACO) is a branch of optimization algorithms modeled based on the behaviour of ants in a colony and a subclass of computational intelligence (IC) paradigms that aids in determining optimal solutions to optimization problems. Compared to selected ACO approaches previously used, Multipath Routing Protocol using Ant Colony Optimization (MRACO) has advantages of minimizing energy consumption and achieves dynamic routing, balances the sensor network node power consumption and minimizes the sensor network lifetime. The main goal of inclusion MRACO into this research is discover the energy efficient paths from the source nodes to the base station to reduce sensor nodes energy usage so as to maximize network lifetime.

In recent years, many routing techniques for WSNs have been proposed such as location aided routing protocols, and graph theory (Gupta et al., 2013). Recently, application of ACO has been extended to wireless sensor networks. The ACO model was first proposed by Marco Dorigo (Marco Dorigo, 1992). Since then, the model has been widely studied and improved. The idea comes from observing the ants' foraging behaviour- how ants find the shortest paths between the food sources and their nest. When searching for food, ants firstly explore the area surrounding their nest in a random manner. While moving, ants deposit a chemical substance, called pheromone, on the paths as they move forming pheromone trails between the food sources and the nest. Thus, when other ants are searching for food, they can smell the pheromone deposited on the paths and they tend to choose a path marked by strong pheromone concentration (Blum and Li, 2008). Each ant also tries to follow the pheromone trail left by previous ants. Thus, these ants have a management structure and exhibit complex co-operative behaviour similar to the properties of dynamic distributed systems. ACO based algorithms have been used in solving continuous optimization problems, discrete optimization problems, complex routing problems in large networks such as travelling salesman problems, knapsack problems, and routing in telecommunication networks, (Engelbrecht, 2007). Figure 5.2 shows the movement of ants' exploitation between the nest (N) and food sources (F). Presently, many improved algorithms have been proposed by different researchers (Marco Dorigo and Birattari, 2010; J.-W. Lee et al., 2011; Pintea et al., 2013).

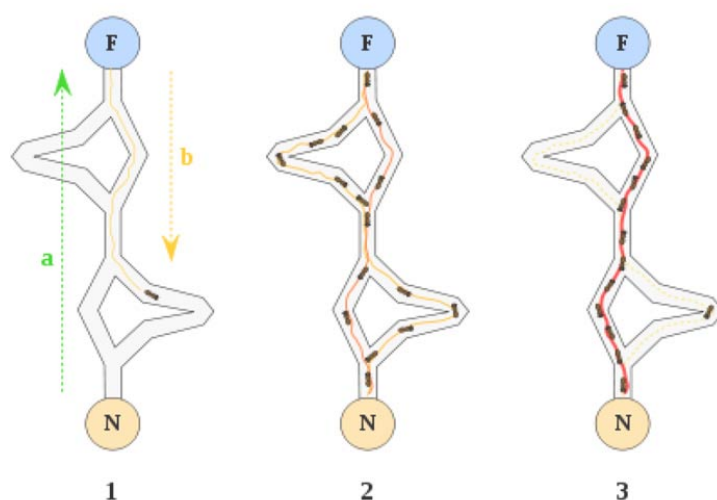

Figure 5.2: Ants exploitation between the food sources (F) and Nest (S)

Ahmed and others in (Ahmed et al., 2012) proposed a novel routing approach using ACO algorithm for WSNs. In the approach called RAACO for simplicity, each ant tries to look for an energy efficient path in the network. Ants are placed at source nodes,  $S$  and move through relay nodes  $r$  until they get to a final destination node  $d$  (base station). Whenever a source node has data to transmit to the base station, launching of the ants is performed. Choice of selecting a relay node is made based on the probabilistic decision rule in equation (5.1)

$$P_{ij}^k(t) = \begin{cases} \frac{[\lambda_{ij}(t)]^\alpha \cdot [\eta_{ij}]^\beta}{\sum_{l \in N_i} [\lambda_{il}(t)]^\alpha \cdot [\eta_{il}]^\beta} & \text{if } j \in N_i^k \\ 0 & \text{otherwise} \end{cases} \quad (5.1)$$

where  $P_{ij}^k$  is the probability of ant  $k$  at node  $v_i$  selecting the next hop node  $v_j$ ,  $\eta_{ij}$  represents the local heuristic value of the path between node  $v_i$  and node  $v_j$ , and  $\lambda_{ij}(t)$  is the pheromone value at time  $t$  on the path  $(i, j)$ .  $N_i$  are neighbour nodes of sensor node  $v_i$ , and  $\alpha$  and  $\beta$  are the two parameters used to control the relative weight of the pheromone trail and the heuristic value respectively.

### 5.1.2 Contribution and Outline

Lee and others in (J. Lee et al., 2012) proposed a radio-disjoint geographic multi-path routing protocol in WSNs (RGM) to improve end-to-end reliability data transmission. The proposed protocol constructs radio-disjoint multiple paths to avoid collisions due to interference between each path. The approach allows multiple paths to keep some distance between each other. The RGM protocol shows better performance compared with the explicit disjoint multiple paths algorithm for cost efficiency in WSNs. However, the authors failed to consider sensor nodes' mobility. Agarwal in (Agarwal, 2013) proposed an energy efficient multi-path routing algorithm in WSNs (EAMR) to improve the efficiency, latency, and resiliency from source nodes to the destination node. The approach constructed primary and alternate paths. The primary path is used for data transmission and the alternate route is used as backup. The simulation results show improve performance compared to LIEMRO and MR2. However, the alternate paths may consume more energy than the primary path.

This chapter revisits the issue of energy efficient routing to assess the relevance of using ant multipath routing as a way of maximizing the lifetime for cluster and backbone sensor networks. The chapter presents the main building blocks of a new multipath routing protocol called MRACO which uses the ant colony optimization paradigm as a way of finding an optimized routing configuration leading to improved performance.

## 5.2 The Multipath Routing Model

This section presents a multi-path routing scheme based on ant colony optimization (ACO) algorithm (MRACO) to minimize energy consumption during communication and achieve load balancing. We make the following improvements on the two parameters used in ACO formula - first is the formula that defines transition probability with which an ant chooses its relay node and the second is the rules which ants use to update the pheromone values on the paths between the nodes. The flowchart for the MRACO is contained in Appendix A. We derive a formula to compute the transition probability using the ideas borrowed from ACO based models proposed in (Marco Dorigo and Birattari, 2010).

### 5.2.1 The Routing Problem

We consider a network model which is based on the following assumptions

1. The sensor nodes are equipped with Omni-directional antennas and are within the communication range of each other. Cluster heads/backbone nodes can communicate with the base station directly and vice versa.
2. Our multipath routing model is constrained based on three main parameters which are used to select the best next-hop from nodes to the base station. These include

*The residual energy of nodes* influences the probabilities with which the node  $v_i$  chooses the node  $v_j$  as the next-hop nodes. The residual energy of a neighbour node  $v_j$  of node  $v_i$  at time  $t$  is  $\omega_{ij}(t) = E_i - E_j(t)$ , where  $E_i$  initial energy levels of the nodes is,  $E_j$  is the current energy level of receiver node  $v_j$ .

*The distance between the nodes* significantly influences the probability with which the node  $v_i$  selects the node  $v_j$  as the next-hop node. Any sensor node  $v_i$  has neighbour nodes given by



$$N_i = \{ v_j \text{ such that } v_j \in N_i, d_{ij} \leq r \} \quad (5.2)$$

where  $r$  is the maximum transmission range of the sensor nodes.  $d_{ij}$  is the Euclidean distance between node  $v_i$  and node  $v_j$ , where the coordinates of the node  $v_i$  and node  $v_j$  are  $x_i$  and  $y_i$  and  $x_j$  and  $y_j$  respectively. It is expressed by

$$d_{ij} = \sqrt{(x_i - x_j)^2 + (y_i - y_j)^2}.$$

- I) **The amount of data currently processed at node  $v_j$**  is considered important because in a large network, there are many source nodes that want to transmit to a base station via next-hop nodes. Nodes selected as the next-hop nodes may be processing data packets received from other source nodes at time  $t$ . If the amount of data is large, other data packets have to wait in a queue until the processing is completed at time  $t + 1$ , increasing the total delivery time that data packets wait in the queue and increasing the consumption of energy. In order to minimize the total waiting time, the amount of data currently processed at node  $v_j$  at time  $t$  denoted by  $\check{a}_j(t)$  should be considered.

The energy maximization can be considered as a multi-constrained local optimization problem expressed as follows consisting of the finding for each node  $v_i$ , a minimal subset of this neighbour's  $N_i$  that solves the following problem:

$$\text{Min } \sum_{j \in N_i} x_j \quad (5.3)$$

subject to

$$P_r(i, j, t) > P_r(i, l, t) \text{ if } \omega_{ij}(t) > \omega_{il}(t) \quad (5.4)$$

$$P_r(i, j, t) > P_r(i, l, t) \text{ if } d_{ij} < d_{il} \quad (5.5)$$

$$P_r(i, j, t) > P_r(i, l, t) \text{ if } \check{a}_j(t) < \check{a}_l(t) \quad (5.6)$$

$$x_j \in \{0, 1\}, \quad \text{for all } j \in N_i \quad (5.7)$$

where  $P_r(i, j, t)$  is the probability that node  $v_i$  selects node  $v_j$  as the next hop to the destination at time  $t$ ,  $x_j$  is an integer number set to zero or one and  $\omega_{ij}(t)$ ,  $d_{ij}$ , and  $\check{a}_j(t)$  are related to the residual energy, the distance and the load of neighbour nodes respectively. As presented above, the multi-constrained routing problem is a local optimization problem consisting of finding a minimal set of neighbours that provide the

potential for maximizing the energy usage. It can be translated into an unconstrained routing problem expressed as follows. At each node  $v_i$ , find the subset  $N_i$  of the neighbours of node  $v_i$  that solves the following problem:

$$\text{Max}_{\{j \in N_i\}} f_{ij}(t) \quad (5.8)$$

$$f_{ij}(t) = \frac{[\omega_{ij}(t)]^{\alpha_3}}{[d_{ij}]^{\alpha_2} [\ddot{a}_j(t)]^{\alpha_2}} \quad (5.9)$$

where  $\alpha_2$  is a parameter that controls the selection of the next-hop node and the amount of data processed at node  $v_j$  at time  $t$ . A higher value of  $\alpha_2$  increases the probability of node  $v_i$  selecting a path with a shorter length and choosing node  $v_j \in N_i$  processing less data.  $\alpha_3$  represents the adjustable weight of  $\omega_{ij}$ . A higher value of  $\alpha_3$  increases the probability of selecting a node with more residual energy as the next-hop candidate node.

### 5.2.2 The Routing Solution

The routing solution proposed in this work builds upon 1) a mapping of the objective function  $f_{ij}(t)$  into a probabilistic objective function  $P_r(i, j)$  and 2) using this probabilistic function as a transition probability for an ant  $k$  at the sensor node  $v_i$  to choose node  $b_j$  as the best next-hop to the base station at time  $t$ . As suggested earlier, the three different parameters are i) the residual energy of the receiver node  $v_j$  (next-hop node) ii) the distance between sender node  $v_i$  and receiver node  $v_j$  and iii) the amount of data currently processed by the receiver node. These parameters are translated into a probabilistic model where

1. The probability of selecting node  $v_j$  as the next-hop node based on residual energy is expressed by

$$\Psi_{ij}(t) = \frac{\omega_{ij}(t)}{\sum_{l \in N_j} \omega_{il}(t)} \quad (5.10)$$

where  $\omega_{il}(t)$  is the residual energy of the neighbour nodes of node  $v_j$  at time  $t$ .

2. The probability of selecting node  $v_j$  as the next-hop node based on distance between nodes  $v_i$  and  $v_j$  is the reciprocal of Euclidian distance given by

$$\Pi_{ij} = \frac{1}{d_{ij}} = \frac{1}{\sqrt{(x_i - x_j)^2 + (y_i - y_j)^2}} \quad (5.11)$$

where  $d_{i,j}$  meters is the length of edge  $(i,j)$  and  $(x, y)$  are the coordinates of nodes  $v_i$  and  $v_j$ .

3. The amount of data currently processed at node  $v_j$  at time  $t$  is denoted by  $\check{a}_j(t)$  and  $\phi_j(t)$  is the loader of sensor node  $v_j$  at time  $t$  expressed as

$$\phi_j(t) = \frac{1}{\check{a}_j(t)} \quad (5.12)$$

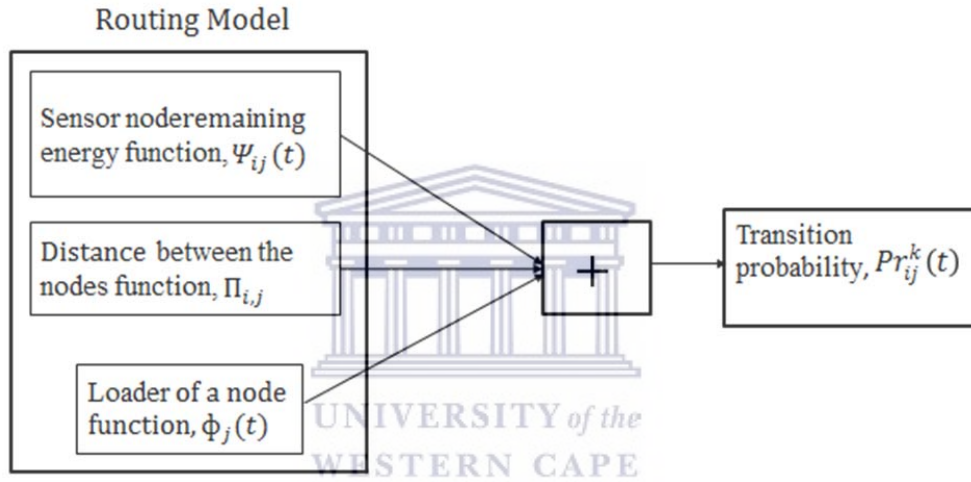

Figure 5.3: Mapping routing parameters into ACO transition probability

As illustrated by Figure 5.3, we define a new probability transition rule with which the ant  $k$  at the sensor node  $v_i$  chooses node  $v_j$  as the next-hop node at the time  $t$  using the expression in equation (5.8) into the basic ACO transition parameter as follows:

$$P_r(i, j, t) = \begin{cases} \frac{[\lambda_{ij}(t)]^{\alpha_1} \Omega_{ij}(t)}{\sum_{l \in N_i} [\lambda_{il}(t)]^{\alpha_1} \Omega_{il}(t)} & \text{if } j \in N_i^K, 0 \text{ otherwise} \end{cases} \quad (5.13)$$

where

$$\Omega_{ij}(t) = \frac{[\Pi_{ij} * \phi_j(t)]^{\alpha_2} [\Psi_{ij}(t)]^{\alpha_3}}{\sum_{l \in N_i} [\Pi_{il} * \phi_l(t)]^{\alpha_2} [\Psi_{il}(t)]^{\alpha_3}} \quad (5.14)$$

and  $P_r(i, j, t)$  is the probability of sensor node  $v_i$  selecting node  $v_j$  as its next hop for data transmission.  $\alpha_1$  is a parameter that controls the influence of the pheromone value. A higher value of  $\alpha_1$  increases the probability of node  $v_i$  selecting a path with a higher pheromone. The heuristic function  $\Omega_{ij}(t)$  is defined in equation (5.14).

Ant  $k$  will select a node with a higher probability value  $P_r(i, j, t)$  at time  $t$  as its next-hop node. Thus, the transition probability formula is used to construct the optimal path between the backbone nodes and the base station as shown in Figure (5.1). Algorithm 5 contains the proposed multi-path routing using ant colony optimization (MRACO).

### 5.3 The MRACO Algorithm

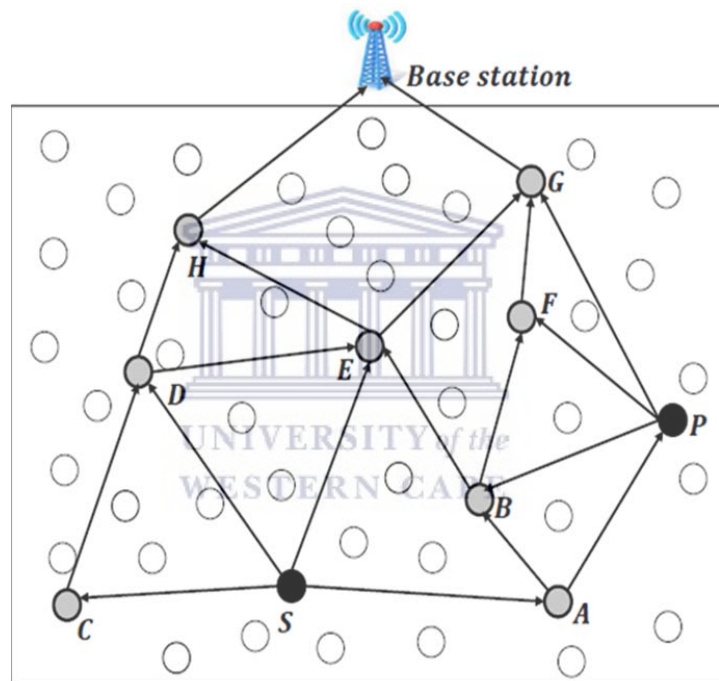

Figure 5.4: Multi-path routing ant colony optimization for WSNs

The basic principle of the MRACO algorithm described below consists of constructing optimal paths between the sender nodes (cluster heads) and the base station by launching, at regular intervals, a forward ant (FA) from these nodes to find an optimal path to the base station.

Consider a network consisting of 500 nodes uniformly distributed in a square area. We use the formula derived for the optimal number of clusters in section 4.7, where the optimal number of clusters for 500 nodes using the free space energy  $\mathcal{E}_{fs} = 10\text{pJ/bit/m}^2$  is ten.

This information is used to divide the network into ten clusters and each cluster contains a cluster head (CH) surrounded by member nodes based on the sensor nodes' received signal strength from the cluster head as shown in Figure 5.4. Every CH is assigned an identification number ID denoted by the capital letters S,P,A,B,C,D,E,F,G,H where S and P denote the source nodes. The network contains 19 links and CHs can communicate with the base station.

Our main objective is to transmit data packets from the source nodes to the base station through optimal paths using the three parameters in equations (5.10) to (5.12) that are energy efficient, have a low packet delay and high throughput. Selecting the shortest paths between the source nodes and the base station may reduce the sensor nodes energy consumption but only to a certain extent, since processing energy, packets delay, and control overhead increase along this route. These constraints are considered in our improved ACO algorithm.

### 5.3.1 Algorithm Illustration

Suppose the base station needs data from the source nodes in a network, the base station broadcasts its identity (ID) to all nodes, each cluster head (CH) stores the base station's ID received into its tabu (memory) and then uses the information to calculate the number of hops to the base station as shown in Table 5.1.

Table 5.1: Number of shortest paths from source nodes to a base station

| Cluster head ID | Number of shortest paths | Cluster head ID | Number of shortest paths |
|-----------------|--------------------------|-----------------|--------------------------|
| S               | 3                        | P               | 2                        |
| C               | 3                        | B               | 3                        |
| D               | 2                        | F               | 2                        |
| E               | 2                        | G               | 1                        |
| A               | 4                        | H               | 1                        |

Assuming the source nodes S and P need to transmit the requested data to the base station, for node S, it can transmit to four nodes – A, C, D, E. Source node S selects node D or E as its relay nodes because they have the same shortest hop count S,D,H, S,H,E and S,E,G as shown in Table 5.1. On the other hand, source node P selects node G as its relay node because its shortest hop count is P,G. Now, we have been able to find the four shortest

paths from the source nodes P and S to the base station. However, using shortest distance as a parameter may not in most cases be energy efficient even though it transmits through a reliable path.

A question could be asked which path among the four shortest paths gives an optimum path in the network? To answer this question, we modify the basic ACO probabilistic decision rule in equation (5.1) to determine the next hop node.

### 5.3.2 Local Pheromone Update

The local pheromone update is performed by all the ants after each construction step. Each ant applies it only to the last edge traversed.

Moreover, the expressions (5.15) and (5.16) are used to update the pheromone value along the path between the node  $v_i$  and node  $v_j$

$$\lambda_{i,j}(t+1) = (1 - \rho)\lambda_{i,j}(t) + \rho\Delta\lambda_{i,j}^k(t+1) \quad (5.15)$$

$$\Delta\lambda_{i,j}^k(t+1) = [K - S_F^k(t)]^{-1} [\check{a}_j(t)]^{-1} \quad (5.16)$$

where  $\lambda_{i,j}$  is the pheromone concentration between node  $v_i$  and node  $v_j$ ,  $\rho$  refers to the pheromone evaporating rate ( $\rho \in (0,1]$ ),  $\Delta\lambda_{i,j}^k$  is the pheromone increment on the path between the two nodes in the current round.  $K$  represents number of cluster heads,  $S_F^k$  represents the total number of nodes visited by the ant  $k$  when moving along path  $F$  at time  $t$ .  $\check{a}_j(t)$  represents the amount of data processed at node  $v_j$  at time  $t$ .

$$\Delta\lambda_{i,j} = \sum_{k=1}^K \Delta\lambda_{i,j}^k \quad (5.17)$$

Equation (5.15) is a local pheromone update rule for the forward ants used to create the paths between the source nodes and the base station. However, the global update is determined as follows

$$\Delta\lambda_{i,j}^k(t+1) = \frac{g(t+1) - g_{best}(t)}{g_{best}(t)} + g(t+1) \quad (5.18)$$

$$g(t) = \frac{E_{min}(v_i)(t)}{\sum_{i=1}^l E(v_i)(t) * d_{ii}(t)} \quad (5.19)$$

$$g_{best}(t) = \max[g(t)] \quad (5.20)$$

where  $g(t)$  is a function to evaluate the current path,  $E_{min}(v_i)$  is a node with minimum energy,  $\sum_{i=1}^l E(v_i)$  is the sum of energy consumption of the sensor nodes along the path F at time  $t$ ,  $g_{best}(t)$  is the current optimal solution obtained.

### 5.3.3 Pheromone Control

The optimal path constructed between the source nodes and the base station will be used to transmit data during data transmission to the base station. However, continuous data transmission along the optimal path may lead to: (a) congestion (b) reduction of the possibility of choosing alternative paths. These two factors are undesirable for a dynamic sensor network because

- (i) Optimal paths may become non-optimal if it is congested;
- (ii) It may lead to loss of data packets due to network failure.

In order to mitigate these two potential problems, pheromone control is used as a measure to reduce the impact from earlier experience and encourages the search for new paths that were non-optimal earlier through evaporation.

Pheromone evaporation is an exploration mechanism that delays pheromone concentration along optimal paths from being excessively high and encourages ants to explore non-optimal paths (P. Kumar and Raghavendra, 2011). In each iteration, the values of pheromone  $\lambda_{ij}$  in all edges are decremented by a factor of  $\rho$  such that  $\lambda_{ij} \leftarrow \lambda_{ij}(1 - \rho)$ .

For instance, at time  $t_i$  all the ants travel along the optimal path and converge to a path  $P_i$ . They leave a very high concentration of pheromone on the optimal path denoted with bigger circles in Figure 5.5. At time  $t_{i+1}$ , the pheromone concentration reduced by some factors is denoted by smaller circles. In the next time  $t_{i+2}$ , the pheromone concentration is further decreased by some factors as shown in the figure.

Evaluation of the above model is presented in section 6.11 and is compared with RAACO, RGM, and EAMR protocols.

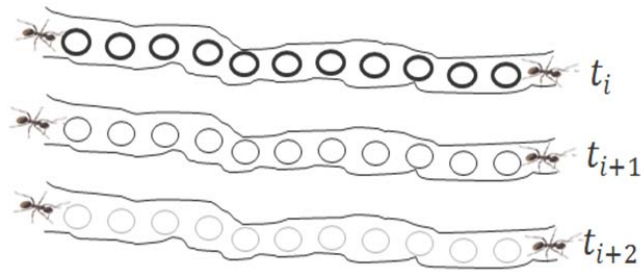

Figure 5.5: Pheromone evaporation

|   |
|---|
| <b>Algorithm 5:</b> Proposed multipath using ACO  |
| <b>Begin</b>  |
| 1: Initialize the number of ants (nodes) $K$ in the network   |
| 2: $F^k$ is a route from source node to a base station found by ant $k$ ;   |
| 3: $L^k$ is the length of route $F^k$ ;   |
| 4: $\lambda_{ij} \leftarrow 0$ ; $t \leftarrow 0$ ;   |
| 5: <b>while</b> all ants have not reached base station <b>do</b>  |
| 6: $t \leftarrow t + 1$ ;   |
| 7: <b>for</b> $k = 1$ to $K$ % create forward ants (FAs)  |
| 8:     A FA is launched at the source node $S$ ;  |
| 9: <b>if</b> $S_i \leftarrow S$ <b>then</b>   |
| 10: $F^k = \emptyset$ ;   |
| 11: <b>end if</b>   |
| 12: <b>while</b> $S_i \neq BS$ <b>do</b> % base station (BS)  |
| 13: <b>if</b> $S(N_i) - N_l^k \neq 0$ <b>then</b> % ( $N_i$ ) all neighbour nodes of $S_i$ ; $N_l$ next neighbor nodes of $S_i$ |
| 14:         Choose $S_j$ from $S(N_i) - N_l^k$ based on probabilistic transmission rule in equation (5.13)                      |
| 15: $F^k \leftarrow F^k \cup \{S_i\}$ ; $L \leftarrow L^k \cup \{S_i\}$ ;   |
| 16: <b>else</b>   |
| 17:         Return to the preceding hop $S_i$ ;   |
| 18: <b>end if</b>   |
| 19: <b>end while</b>  |
| 20:     Compute pheromone values deposited on the paths by the equation (5.17)  |
| 21:     Update the pheromone value $\lambda_{ij}$ on the paths travelled by the equations (5.15) and (5.16)                     |
| 22:     Calculate the length $L^k$ of $F^k$ using Euclidean distance $d_{ij}$ in equation (5.10)                                |
| 23: <b>if</b> $BS \leftarrow S_i$ <b>then</b>   |
| 24:         Create backward ants (BAs) at the base station  |
| 25: <b>end if</b>   |
| 26: <b>while</b> $BS \neq S_i$ <b>do</b>  |
| 27:         Update the pheromone value in the reverse path $F^k$ by the equations (5.18) and (5.19)                             |
| 28:         Update the pheromone in whole paths by the equations (5.15), (5.17) to (5.19)                                       |
| 29: <b>end while</b>  |
| 30:     Return the optimal solutions by equation (5.20)   |
| 31: <b>end for</b>  |
| 32: <b>end while</b>  |
| <b>End</b>  |



## 5.4 Chapter summary

This chapter presents the main building blocks of a new multipath routing protocol called multipath routing using ant colony optimization (MRACO). MRACO uses the ant colony optimization paradigm as a way of finding an optimized routing configuration leading to improved performance. The sensor network is organized into hierarchical backbone-based network where a set of more powerful nodes forming the network backbone are used as transit for other nodes to transmit their sensor readings to the gateway.

We formulated a model for the multipath routing, the model considered three main parameters which are used to select the best next-hop from the source nodes to the base station. These include: the residual energy of the sensor nodes, the distance between the nodes, and the amount of data processed at the receiver's node at time  $t$ .

These three parameters are used for the heuristic function to obtain a new probability transition rule with which the ant  $k$  at the sensor node  $v_i$  chooses node  $v_j$  as the next-hop node at time  $t$ . In addition, MRACO algorithm is presented and illustrated with the diagram.

This chapter concludes with the introduction of pheromone control to discourage continuous data transmission through the optimal path and encourages the search of new paths that were non-optimal previously through evaporation.

The next chapter presents the simulation results and discussion on each of the results obtained.

## Chapter 6

### 6 Performance evaluation of the proposed protocol

This chapter discusses the performance evaluation of the results obtained through simulation using MATLAB. The proposed EOCIT protocol is simulated on a different number of nodes ranging from 100 to 500. In each network, the sensor nodes are randomly distributed on a 100m x 100m sensor area unless otherwise stated. All simulations are run 80 times generating different topologies to obtain accurate results. The average values of the results are then determined. The average results are used for the plotting of the figures. The initial energy of each sensor node is 1Joule with a maximum transmission range of 75m. The sensor nodes are equipped with an Omni-directional antenna for transmitting and receiving data (Catarinucci et al., 2013). The IEEE 802.15.4 communications protocol standard is considered for this work. The performance of EOCIT is compared with LDD (discussed in section 2.9.2), DECSA, and MOCRN protocols. The flowchart for the EOCIT is contained in Appendix B. LDD, DECSA, and MOCRN protocols have been discussed in chapter two and the proposed EOCIT protocol is discussed in chapter four.

All except the load balance directed diffusion (LDD) protocol are clustering protocols. LDD protocol is included in the first part of the experiment to see if there is any significant difference in terms of energy consumption between direct transmission and clustering schemes in a sensor network.

The energy models proposed in chapter three are used for the implementation of the EOCIT protocol. The metrics discussed in section 6.1, are used to check the performances of the protocols and parameters used in the simulation are contained in Table 6.1.

## 6.1 Metrics used in the simulation

It is worth mentioning that the constraints of wireless sensor nodes addressed in this research are evaluated using the following metrics.

*Average Energy Consumption:* The average energy consumption is the difference between the initial energy level and the final energy level that is left in each sensor node in a network lifetime.

$$E_a = \frac{\sum_{i=1}^V E_i - E_f}{V}$$

*Packet Delivery Ratio:* It is the ratio of the total number of data packets successfully received at the destination node to the number of data packets transmitted by the source nodes in the network

$$\frac{\text{Total Number of Data Received}}{\text{Number of Data Transmitted}}$$

The greater the value of the data delivery ratio, the better the performance of the protocol.

*Packet Lost:* It is the total number of data packets dropped during the simulation time.

Packet lost = Number of packets sent – Number of packets received.

The lower the value of the packet lost, the better the performance of the protocol.

*Network lifetime:* The definition of sensor nodes lifetime is application specific. It can be defined in many ways, depending on the application area.

Network lifetime is similar to the network partition and network coverage ratio (Ren et al., 2011). It can be defined in three different ways as given below

- *Time until First Node Dies (FND):* The time from the distribution of the sensor nodes to the time that the first node runs out of energy and dies.
- *Percentage Nodes Alive (PNA):* The amount of time that a certain percentage of sensor nodes are alive.
- *Last Node Dies (LND):* The point in time when the last sensor node in the network dies.

On the other hand, the network lifetime of wireless sensor networks (WSNs) can also be defined as the time span from deployment to moment that the network ceases to achieve

the objectives of its deployment (A. Kumar et al., 2011). A sensor node lifetime is defined as

$$\text{Sensor Node Lifetime} = \frac{\text{Initial battery capacity}}{\text{Average current energy} * 365 * 24} \text{ [years]},$$

where the units of initial battery capacity and the average current energy are mAh and mA respectively.

*Throughput:* The total number of data delivered over the total simulation time. The higher the value of the throughput means the better the performance of the protocol.

*End-to-end Packets Delay:* It measures the average time it takes to transmit a data packet from the source node to the destination node. The lower the end-to-end delay the better the performance of the protocol.

Table 6.1: Parameters used in the simulations

| Table 6.1: Parameters used in the simulation | Values  |
|--|---|
| Number of Nodes (N)                          | 100, 200, 300, 400, 500                                 |
| Network area                                 | (100 x 100) m <sup>2</sup> ~ (400 x 400) m <sup>2</sup> |
| Initial energy of normal node                | 1 Joule   |
| Initial energy of hybrid node                | 1.5 Joules  |
| Initial network energy                       | 100 Joules  |
| Receiver sensitivity                         | -96 dBm   |
| $\epsilon_{fs}$                              | 7nJ/bit/m <sup>2</sup> and 10 pJ/bit/m <sup>2</sup>     |
| Packet size                                  | 4000 bits   |
| $E_{ele}$                                    | 50nJ/bit  |
| $E_{amp}$                                    | 0.0013pJ/bit/m <sup>4</sup>                             |
| Threshold energy                             | $E_T$   |
| Energy for Data Aggregation                  | 5nJ/bit   |
| Base station location                        | (40~180)m   |
| Transmission range                           | 75m   |
| Transmit power                               | 0.395 W   |
| Idle Power                                   | 0.335W  |
| Receiving Power                              | 0.360W  |

## 6.2 Comparing cluster-based and tree topology

In many practical wireless networks, the tree topology using direct transmission from nodes to the access points has been favoured due to its simplicity of deployment. However, the tree topology might not be the most energy efficient. This section reports on a set of experiments that we conducted to compare direct transmission using a star network topology and a cluster based topology.

We run simulation on the LDD protocol discussed in section 2.9.2 based on the direct transmission of data to the base station and EOCIT protocol based on the clustering scheme using the energy model proposed in section 3.2. The base station for the two scenarios is located at the center of the network to determine the energy consumption of the sensor nodes during communication using sensor nodes ranging from 100 to 500. Each network size is randomly distributed for twenty times to form different topologies. The simulation for each network size runs for 1000 times over a 100m x 100m sensor area.

The Statistical Package for the Social Sciences (SPSS) is used to analyze the values obtained. The Mean, Variance, and Standard Deviation for each network size are determined. The values of energy consumption obtained for the two scenarios are shown in Table 6.2 and Table 6.3 respectively. A hypothesis is formulated to determine the significant difference in the energy consumption of the sensor nodes between direct transmission and clustering protocols.

Table 6.2: Energy consumption of sensor nodes using clustering method

| No of Tests<br>(Runs)     | Number of Sensor Nodes |                  |                  |                  |                  |
|---------------------------|------------------------|------------------|------------------|------------------|------------------|
|                           | 100<br>(mJoules)       | 200<br>(mJoules) | 300<br>(mJoules) | 400<br>(mJoules) | 500<br>(mJoules) |
| 1st                       | 27.1                   | 31.7             | 31.1             | 31.4             | 32.7             |
| 2nd                       | 26.4                   | 30.2             | 31.8             | 31.9             | 31.4             |
| 3rd                       | 27.9                   | 29.3             | 30.7             | 30.8             | 33.1             |
| 4th                       | 27.8                   | 29.4             | 31.2             | 31.1             | 32.8             |
| 5th                       | 28.7                   | 32.9             | 30.6             | 32               | 32.4             |
| 6th                       | 28.3                   | 30.5             | 31.4             | 30.8             | 31.6             |
| 7th                       | 27.3                   | 30.4             | 30.5             | 31.2             | 31.9             |
| 8th                       | 26.8                   | 31.6             | 30.9             | 32               | 32               |
| 9th                       | 29.3                   | 29.8             | 29.9             | 31.8             | 31.2             |
| 10th                      | 28.1                   | 29.7             | 30.1             | 31.4             | 33               |
| 11th                      | 26.7                   | 30.1             | 31               | 31.6             | 32.7             |
| 12th                      | 27.1                   | 31.8             | 30.8             | 29.9             | 32.1             |
| 13th                      | 28.3                   | 28.8             | 29.4             | 30.1             | 32.8             |
| 14th                      | 27.6                   | 31.2             | 30.2             | 31.2             | 32.5             |
| 15th                      | 27.3                   | 28.6             | 31.1             | 30.5             | 31.7             |
| 16th                      | 28.9                   | 29.7             | 30.8             | 32.1             | 30.8             |
| 17th                      | 27.8                   | 28.7             | 30.6             | 32.8             | 31.2             |
| 18th                      | 28.9                   | 29.1             | 31.2             | 31               | 30.8             |
| 19th                      | 27.4                   | 31.5             | 30.6             | 32.2             | 31.4             |
| 20th                      | 28.5                   | 29.2             | 31.4             | 32.4             | 32               |
| <b>Total</b>              | 556.2                  | 604.2            | 615.3            | 628.2            | 640.1            |
| <b>Mean</b>               | 27.81                  | 30.21            | 30.765           | 31.41            | 32.005           |
| <b>Variance</b>           | 0.654                  | 1.473            | 0.320            | 0.582            | 0.528            |
| <b>Standard Deviation</b> | 0.808                  | 1.213            | 0.566            | 0.763            | 0.727            |

Table 6.3: Energy consumption of Sensor Nodes using Direct Transmission Method

| No of Tests<br>(Runs)     | Number of Sensor Nodes |                 |                 |                 |                 |
|---------------------------|------------------------|-----------------|-----------------|-----------------|-----------------|
|                           | 100<br>(mJoule)        | 200<br>(mJoule) | 300<br>(mJoule) | 400<br>(mJoule) | 500<br>(mJoule) |
| 1st                       | 30.5                   | 31.2            | 32.3            | 32.7            | 33.1            |
| 2nd                       | 29.1                   | 32.8            | 31.7            | 33.4            | 33.8            |
| 3rd                       | 28.9                   | 31.1            | 31.5            | 35.1            | 34.2            |
| 4th                       | 29.3                   | 30.4            | 30.2            | 33.1            | 33.9            |
| 5th                       | 30.1                   | 29.7            | 32.6            | 32.6            | 33.7            |
| 6th                       | 29.3                   | 33.2            | 32.7            | 32.7            | 32.9            |
| 7th                       | 28.4                   | 32.1            | 33              | 33.4            | 32.4            |
| 8th                       | 28.7                   | 32.3            | 32.5            | 32.4            | 32.4            |
| 9th                       | 29.3                   | 31.3            | 32.4            | 34.5            | 32.2            |
| 10th                      | 31.8                   | 30.4            | 32.6            | 32.5            | 32.6            |
| 11th                      | 28.3                   | 31.6            | 31.4            | 34.1            | 33.2            |
| 12th                      | 27.1                   | 30.9            | 32.1            | 32.9            | 33.5            |
| 13th                      | 29.5                   | 32.4            | 32.6            | 31.7            | 32.9            |
| 14th                      | 28.2                   | 31.2            | 33.2            | 32.6            | 33              |
| 15th                      | 27.3                   | 30.5            | 30.9            | 32.8            | 34.8            |
| 16th                      | 28.6                   | 31.2            | 31.7            | 32.7            | 33.1            |
| 17th                      | 29.4                   | 30.1            | 32.4            | 33.1            | 33.8            |
| 18th                      | 27.1                   | 30.1            | 31.2            | 32.4            | 32.2            |
| 19th                      | 28.5                   | 31.5            | 31.6            | 33.7            | 32.5            |
| 20th                      | 30.9                   | 30.2            | 32.1            | 32.8            | 33.2            |
| <b>Total</b>              | 580.3                  | 624.2           | 640.7           | 661.2           | 663.4           |
| <b>Mean</b>               | 29.015                 | 31.21           | 32.035          | 33.06           | 33.17           |
| <b>Variance</b>           | 1.458                  | 0.938           | 0.563           | 0.630           | 0.498           |
| <b>Standard Deviation</b> | 1.208                  | 0.968           | 0.751           | 0.794           | 0.706           |

Based on the results obtained above, we can see that for the same network size for the two scenarios, the sensor node energy consumption is not the same due to random distribution of the sensor nodes. However, as the of sensor nodes increases, more energy is consumed as a result of an increase in number of the sensor nodes. The network with 500 nodes consumed the highest energy as depicted in both tables.

### Statistical Analysis

A significant test interpretation was carried out in this study with the main purpose to establish the relationship between direct communication and clustering schemes in terms of energy consumption during the required network lifetime.

Hypothesis for Null hypothesis ( $H_0$ ) and Acceptance hypothesis ( $H_1$ ) are formulated as follows

**$H_0$ :** There is no significant difference in the energy consumption of sensor nodes between the LDD protocol based on direct transmission and the EOCIT protocol based on clustering.

**$H_1$ :** There is significant difference in the energy consumption of sensor nodes between the LDD protocol based on direct transmission and the EOCIT protocol based on clustering.

The SPSS software is used for the computation and the result is shown in Figure 6.1. The mean, variance, and standard deviation of energy consumption for nodes ranging from 100 to 500 in both protocols are computed below and the summary is presented in Table 6.4.

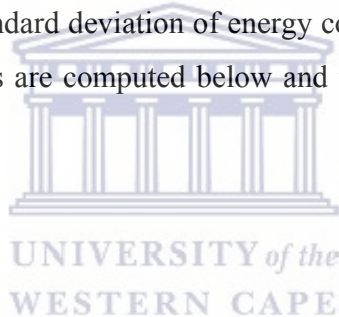



### EOCIT Protocol

$$\bar{x}_{100 \text{ Nodes}} = \frac{\Sigma\chi}{N} = \frac{556.2}{20} = 27.81$$

$$S^2_{100 \text{ Nodes}} = \frac{\Sigma_{i=1}^n (x_i - \bar{x})^2}{n-1} = 0.65$$

$$\text{Std}_{100 \text{ Nodes}} = \sqrt{\frac{\Sigma_{i=1}^n (x_i - \bar{x})^2}{n-1}} = 0.81$$

$$\bar{x}_{200 \text{ Nodes}} = \frac{\Sigma\chi}{N} = \frac{604.2}{20} = 30.21$$

$$S^2_{200 \text{ Nodes}} = \frac{\Sigma_{i=1}^n (x_i - \bar{x})^2}{n-1} = 1.47$$

$$\text{Std}_{200 \text{ Nodes}} = \sqrt{\frac{\Sigma_{i=1}^n (x_i - \bar{x})^2}{n-1}} = 1.21$$

$$\bar{x}_{300 \text{ Nodes}} = \frac{\Sigma\chi}{N} = \frac{615.3}{20} = 30.77$$

$$S^2_{300 \text{ Nodes}} = \frac{\Sigma_{i=1}^n (x_i - \bar{x})^2}{n-1} = 0.32$$

$$\text{Std}_{300 \text{ Nodes}} = \sqrt{\frac{\Sigma_{i=1}^n (x_i - \bar{x})^2}{n-1}} = 0.57$$

$$\bar{x}_{400 \text{ Nodes}} = \frac{\Sigma\chi}{N} = \frac{628.2}{20} = 31.41$$

$$S^2_{400 \text{ Nodes}} = \frac{\Sigma_{i=1}^n (x_i - \bar{x})^2}{n-1} = 0.58$$

$$\text{Std}_{400 \text{ Nodes}} = \sqrt{\frac{\Sigma_{i=1}^n (x_i - \bar{x})^2}{n-1}} = 0.76$$

$$\bar{x}_{500 \text{ Nodes}} = \frac{\Sigma\chi}{N} = \frac{640.1}{20} = 32.01$$

$$S^2_{500 \text{ Nodes}} = \frac{\Sigma_{i=1}^n (x_i - \bar{x})^2}{n-1} = 0.53$$

$$\text{Std}_{500 \text{ Nodes}} = \sqrt{\frac{\Sigma_{i=1}^n (x_i - \bar{x})^2}{n-1}} = 0.73$$

### LDD Protocol

$$\bar{x}_{100 \text{ Nodes}} = \frac{\Sigma\chi}{N} = \frac{580.3}{20} = 29.02$$

$$S^2_{100 \text{ Nodes}} = \frac{\Sigma_{i=1}^n (x_i - \bar{x})^2}{n-1} = 1.46$$

$$\text{Std}_{100 \text{ Nodes}} = \sqrt{\frac{\Sigma_{i=1}^n (x_i - \bar{x})^2}{n-1}} = 1.21$$

$$\bar{x}_{200 \text{ Nodes}} = \frac{\Sigma\chi}{N} = \frac{624.2}{20} = 31.21$$

$$S^2_{200 \text{ Nodes}} = \frac{\Sigma_{i=1}^n (x_i - \bar{x})^2}{n-1} = 0.94$$

$$\text{Std}_{200 \text{ Nodes}} = \sqrt{\frac{\Sigma_{i=1}^n (x_i - \bar{x})^2}{n-1}} = 0.97$$

$$\bar{x}_{300 \text{ Nodes}} = \frac{\Sigma\chi}{N} = \frac{640.7}{20} = 32.04$$

$$S^2_{300 \text{ Nodes}} = \frac{\Sigma_{i=1}^n (x_i - \bar{x})^2}{n-1} = 0.56$$

$$\text{Std}_{300 \text{ Nodes}} = \sqrt{\frac{\Sigma_{i=1}^n (x_i - \bar{x})^2}{n-1}} = 0.75$$

$$\bar{x}_{400 \text{ Nodes}} = \frac{\Sigma\chi}{N} = \frac{661.2}{20} = 33.06$$

$$S^2_{400 \text{ Nodes}} = \frac{\Sigma_{i=1}^n (x_i - \bar{x})^2}{n-1} = 0.63$$

$$\text{Std}_{400 \text{ Nodes}} = \sqrt{\frac{\Sigma_{i=1}^n (x_i - \bar{x})^2}{n-1}} = 0.79$$

$$\bar{x}_{500 \text{ Nodes}} = \frac{\Sigma\chi}{N} = \frac{663.4}{20} = 33.17$$

$$\text{Std}_{500 \text{ Nodes}} = \sqrt{\frac{\Sigma_{i=1}^n (x_i - \bar{x})^2}{n-1}} = 0.50$$

$$S^2_{500 \text{ Nodes}} = \frac{\Sigma_{i=1}^n (x_i - \bar{x})^2}{n-1} = 0.71$$

Table 6.4: Summary of the energy consumption by EOCIT and LDD protocols

| Group Statistics |          |                    |         |                |                 |
|------------------|----------|--------------------|---------|----------------|-----------------|
| No. of Nodes     | Protocol | Different Topology | Mean    | Std. Deviation | Std. Error Mean |
| N_100            | EOCIT    | 20                 | 27.8100 | 0.80844        | 0.18077         |
|                  | LDD      | 20                 | 29.0150 | 1.20755        | 0.27002         |
| N_200            | EOCIT    | 20                 | 30.2100 | 1.21348        | 0.27134         |
|                  | LDD      | 20                 | 31.2100 | 0.96840        | 0.21654         |
| N_300            | EOCIT    | 20                 | 30.7650 | 0.56594        | 0.12655         |
|                  | LDD      | 20                 | 32.0350 | 0.75063        | 0.16785         |
| N_400            | EOCIT    | 20                 | 31.4100 | 0.76289        | 0.17059         |
|                  | LDD      | 20                 | 33.0600 | 0.79366        | 0.17747         |
| N_500            | EOCIT    | 20                 | 32.0050 | 0.72655        | 0.16246         |
|                  | LDD      | 20                 | 33.1700 | 0.70569        | 0.15780         |

The statistical significant differences between the two protocols after the analysis was done are shown in Figure 6.1. For clarity sake, the same results are presented in Table 6.5.

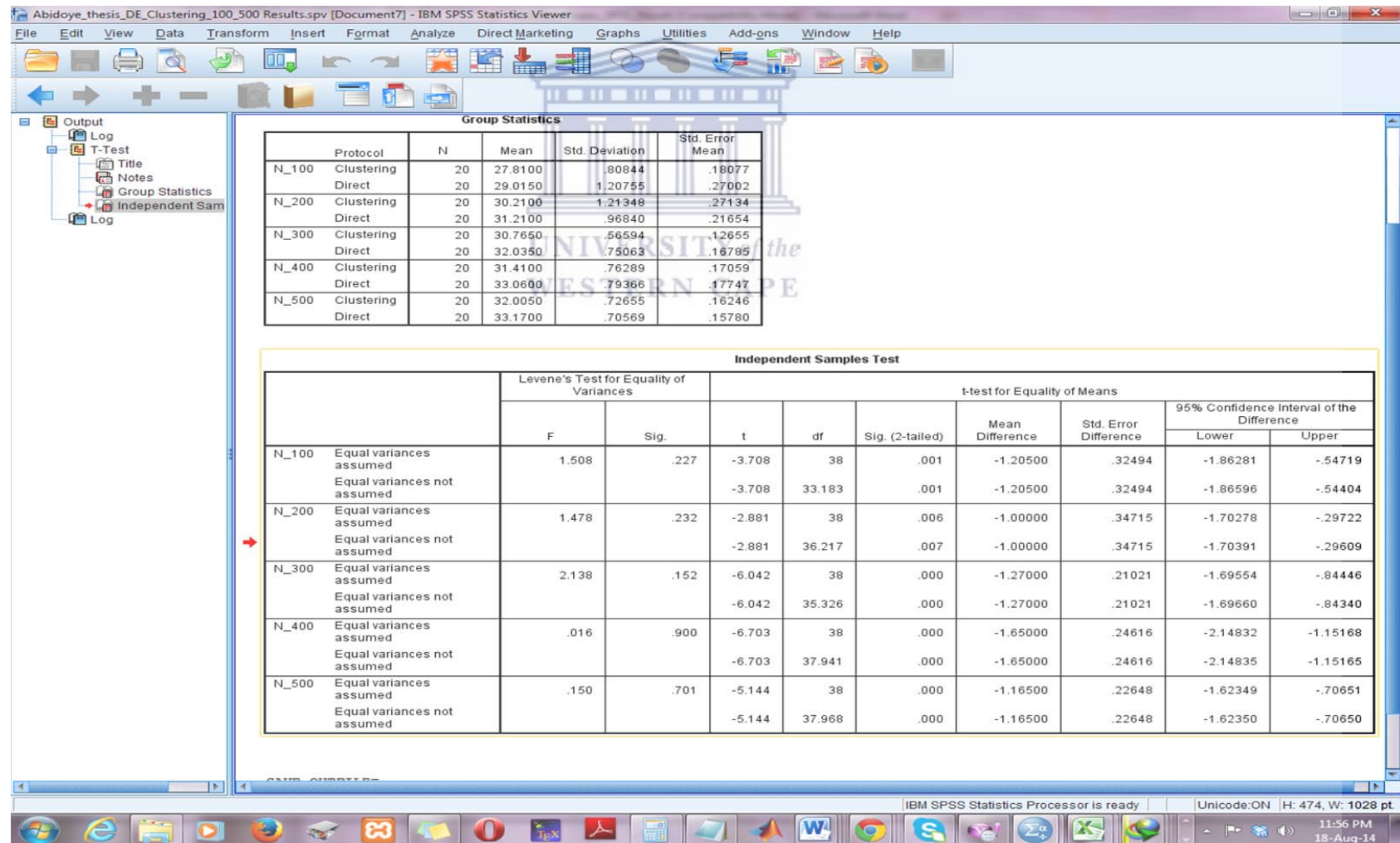

Figure 6.1: T-Test for the significant difference between EOCIT and clustering protocols

Table 6.5: The 2-tailed independent samples test

|       |                             | Levene's Test for Equality of Variances |      | t-test for Equality of Means |        |                 |                 |                       |   |          |
|-------|-----------------------------|---|------|------------------------------|--------|-----------------|-----------------|-----------------------|---|----------|
|       |                             | F                                       | Sig. | t                            | df     | Sig. (2-tailed) | Mean Difference | Std. Error Difference | 95% Confidence Interval of the Difference |          |
|       |                             |   |      |                              |        |                 |                 |                       | Lower                                     | Upper    |
| N_100 | Equal variances assumed     | 1.508                                   | .227 | -3.708                       | 38     | .001            | -1.20500        | .32494                | -1.86281                                  | -.54719  |
|       | Equal variances not assumed |   |      | -3.708                       | 33.183 | .001            | -1.20500        | .32494                | -1.86596                                  | -.54404  |
| N_200 | Equal variances assumed     | 1.478                                   | .232 | -2.881                       | 38     | .006            | -1.00000        | .34715                | -1.70278                                  | -.29722  |
|       | Equal variances not assumed |   |      | -2.881                       | 36.217 | .007            | -1.00000        | .34715                | -1.70391                                  | -.29609  |
| N_300 | Equal variances assumed     | 2.138                                   | .152 | -6.042                       | 38     | .000            | -1.27000        | .21021                | -1.69554                                  | -.84446  |
|       | Equal variances not assumed |   |      | -6.042                       | 35.326 | .000            | -1.27000        | .21021                | -1.69660                                  | -.84340  |
| N_400 | Equal variances assumed     | .016                                    | .900 | -6.703                       | 38     | .000            | -1.65000        | .24616                | -2.14832                                  | -1.15168 |
|       | Equal variances not assumed |   |      | -6.703                       | 37.941 | .000            | -1.65000        | .24616                | -2.14835                                  | -1.15165 |
| N_500 | Equal variances assumed     | .150                                    | .701 | -5.144                       | 38     | .000            | -1.16500        | .22648                | -1.62349                                  | -.70651  |
|       | Equal variances not assumed |   |      | -5.144                       | 37.968 | .000            | -1.16500        | .22648                | -1.62350                                  | -.70650  |

A 2-tailed independent samples test was performed using t-test at 95% Confidence Interval. The results are compared with  $p$ -value.

#### *p-value*

The  $p$ -value measures consistency between the results actually obtained in the experiments and the “pure chance” explanation for those results. The  $p$ -value is also known as the *observed significance level*.  $p$ -value is obtained for each network size 100,200,300,400, and 500 sensor nodes. The value is compared with the statistical significant value alpha ( $\alpha$ ). The alpha level ( $\alpha$ ) specified for this experiment is  $\alpha = 0.05$  (5%).

The 0.05 level of significance indicates that there is a 5% chance that under the null hypothesis, the observations could have occurred by chance.

If the calculated  $p$ -value is smaller than the significance level  $\alpha$  (probability in the rejection region), then the null hypothesis is rejected. On the other hand, if the calculated  $p$ -value is greater than or equal to  $\alpha$ , then the alternate hypothesis is rejected.

Five  $p$ -values were obtained from the experiments for each network as shown in Table 6.5.

#### *Sensor Network with 100 nodes*

The observed significance level,  $p$  obtained from Figure 6.1 for 100 nodes is 0.001.

It is less than  $\alpha = 0.05$ . Therefore, we reject the null hypothesis  $H_0$  and accept the alternative hypothesis. The reason is due to different energy models used for LDD (direct transmission) and EOCIT (clustering).

Similarly, the  $p$  value obtained for 200,300,400 and 500 sensor nodes are 0.007, 0.000, 0.000 and 0.000 respectively. Each of these values is less than the significance level of 0.05. Therefore, we reject the null hypothesis  $H_0$ , which says there is no significant difference in the energy consumption of sensor nodes between LDD based on direct transmission and EOCIT based on clustering.

Based on the results obtained above, we can establish that there is significant difference in the energy consumption of sensor nodes between direct transmission protocol and clustering protocol. Therefore, partitioning sensor networks into clusters will save more energy than direct data transmission to a base station particularly for a large number of sensor nodes.

### *Optimal number of clusters for the Protocols*

Overall system scalability, energy efficiency, and prolonged network lifetime depend upon the optimal number of clusters and even distribution of cluster heads in a network. A network with less than the optimal number of clusters will quickly exhaust the limited energy available to the cluster heads due to the large amount of data transmitted from member nodes. On the other hand, a larger number of clusters (more than the optimal number), will congest the network area and more energy will be consumed. Therefore, the number of clusters formed should be optimal for extending the sensor network lifetime.

The formula derived in section 4.7 is used to obtain the optimal number of clusters for DECSA, MOCRN, and EOCIT protocols using the free space energy  $\mathcal{E}_{fs} = 10\text{pJ/bit/m}^2$ , number of nodes  $N=100$  and network length of  $M=100\text{m}$  as shown in Table 6.6. The difference in the optimal clusters is as a result of the different energy models used for each protocol, location of the base station and number of nodes in the network.

Table 6.6: Optimal number of clusters for different protocols

| Protocol | $\mathcal{E}_{fs} = 10\text{pJ/bit/m}^2$ |  |
|----------|--|--|
|          | Optimal number of clusters               | Distance range for optimal clusters $70 \leq d_{\text{toBS}} \leq 180\text{m}$ |
| EOCIT    | 4  | 1-6  |
| MOCRN    | 5  | 1-9  |
| DECSA    | 6  | 2-10   |

Further experiments are performed and the results obtained are shown in Figure 6.2 and Figure 6.3 using the optimal number of clusters. The results correspond to the number of clusters obtained through the analytical method as shown in Table 6.6.

We assume that each cluster contains only one cluster head.

The cluster  $K$  is varied from 1 to 8 to get the optimal cluster. The optimal value is obtained when  $K = 4$  for EOCIT using free space energy  $\mathcal{E}_{fs} = 10\text{pJ/bit/m}^2$ . The total energy consumption increases as the clusters increase (i.e on the right hand of the optimal value). The number of clusters is plotted against total energy consumption (TEC), as shown in Figure 6.2.

Furthermore, we increase the number of sensor nodes from 100 to 500 using the same free space energy, the optimal number of clusters is obtained when  $K=10$  for a network size of 500 nodes as shown in Figure 6.3. It is observed that when the number of clusters is between one and nine more energy is consumed than when  $K$  is greater than ten. The reason is that when the number of cluster heads is less than the optimal number, the nodes transmit through long distance to their respective cluster heads and more energy is dissipated. On the other hand, when the cluster heads are more than the optimal number, sensor nodes transmit through a short distance to their cluster heads. The energy consumption is at a lower rate than when the cluster heads are below the optimal number.

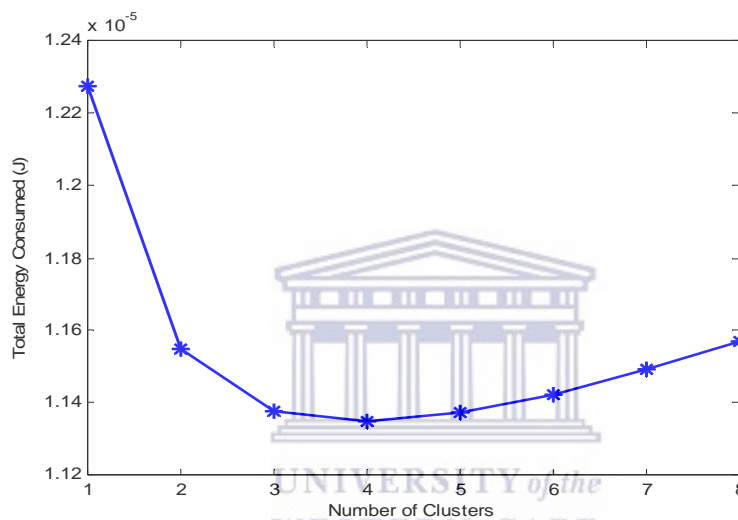

Figure 6.2: Total energy consumed vs number of clusters,  $V=100$

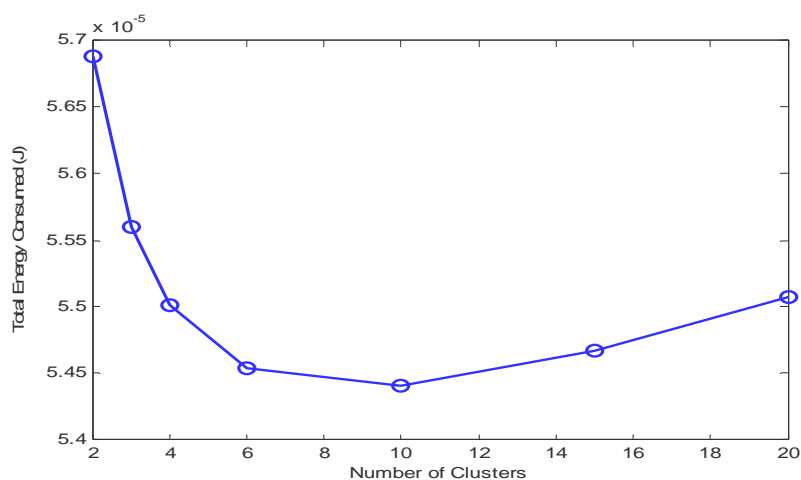

Figure 6.3: Total energy consumed vs number of clusters,  $V=500$

### 6.3 Effect of sensor nodes and distance of cluster heads from the base station

We investigate how the number of sensor nodes affects the lifetime of sensor nodes and the optimal number of clusters in a given square network field. The simulation results are shown in Figure 6.4 using number of sensor nodes ranging from 100 to 500, network of length  $M=100$ , and  $\varepsilon_{fs} = 10pJ/bit/m^2$ .

We use the value for the optimal number of clusters for each protocol for Figure 6.4. It is observed that as the number of sensor nodes increases, the optimal number of clusters likewise increases in all the protocols. The EOCIT protocol has the least number of optimal clusters for the different number of sensor nodes considered compared to the DECSA and the MOCRN protocols. This is due to the even distribution of cluster heads within the network using the algorithms.

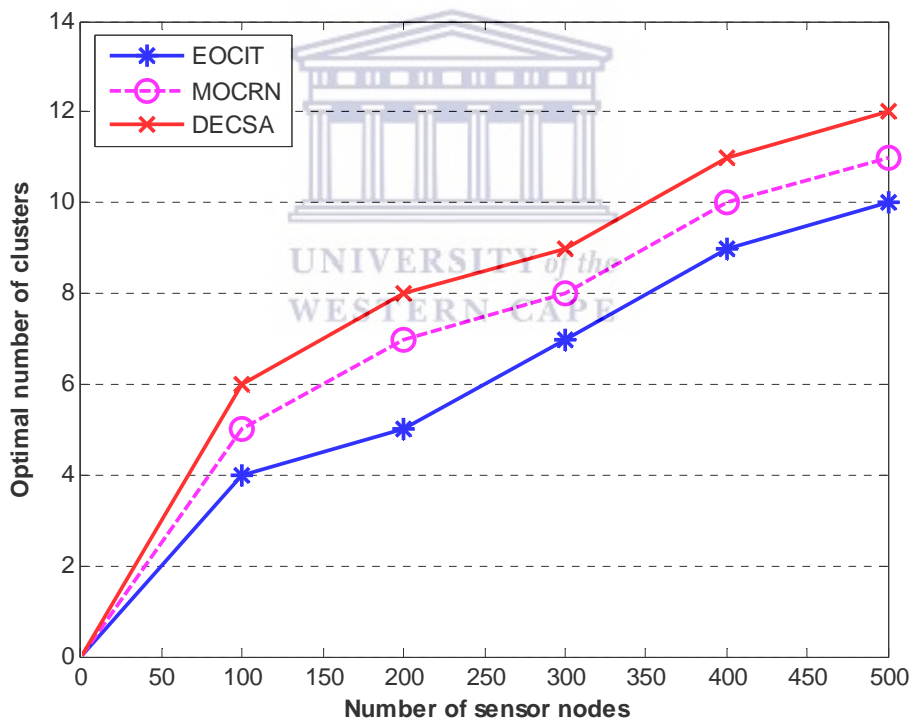

Figure 6.4: Optimal number of clusters vs number of sensor nodes



#### 6.4 Significance of free space energy model

The optimal number of clusters derived in section 4.7 is only relevant if the free space energy  $\varepsilon_{fs}$  is assumed to be the same at all times (Ghosh and Chakraborty, 2006) which may be impractical in most cases. This may be as a result of constant changes in the network topology caused by the addition of new nodes into the network or the death of some nodes. Based on this, simulation is performed using five different free spaces fading energy in the range  $10\text{pJ/bit/m}^2$  to  $10000\text{pJ/bit/m}^2$ . It is observed that as the free fading space energy increases, the optimal number of clusters likewise increases and more energy is dissipated per round as shown in Figure 6.5. Moreover, average energy consumption decreases as the number of cluster increases before the optimal number of clusters is reached. This is due to the short communication distance between the nodes. Shortly after the optimal number of clusters has been exceeded, energy consumption increases because cluster heads dissipated more energy than normal nodes during communication. The number of cluster heads is directly proportional to the energy consumption in a network.

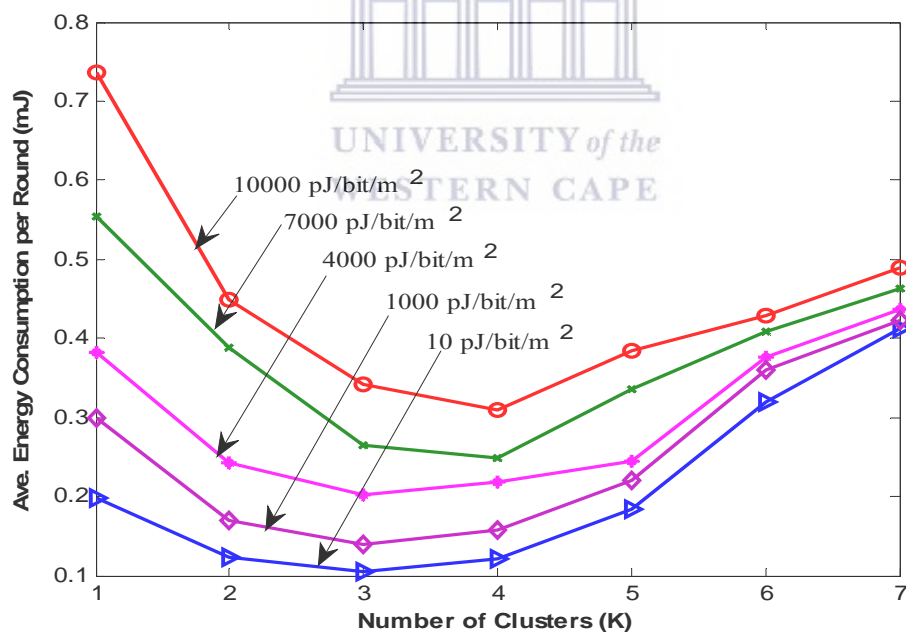

Figure 6.5: Average energy consumption vs number of clusters for EOCIT protocol

### Parameters used for cluster heads selection

In the proposed protocol, the parameters used for the selection of the cluster heads in section 4.3 are evaluated here.  $\alpha$  and  $\beta$  are parameters which determine the proportion of communication cost factor and energy cost respectively. They determine the probability of choosing a node as the next cluster head in a cluster, where the sum of  $\alpha$  and  $\beta$  is equal to 1. The value of  $\alpha$  is varied to determine when the 1st node dies, 20% nodes die, and 50% nodes die. It is observed that when the value of  $\alpha$  is 0.8 as shown in Figure 6.6, the moment when the first node dies and 20% nodes die are higher than other values of  $\alpha$ . In addition, when  $\alpha$  is within the range 0.72 to 0.76, the node's time of death of 50% sensor nodes appears the highest. The reason for the increase is that most nodes have almost exhausted their energy at these points, and the remaining nodes transmit through long distance.

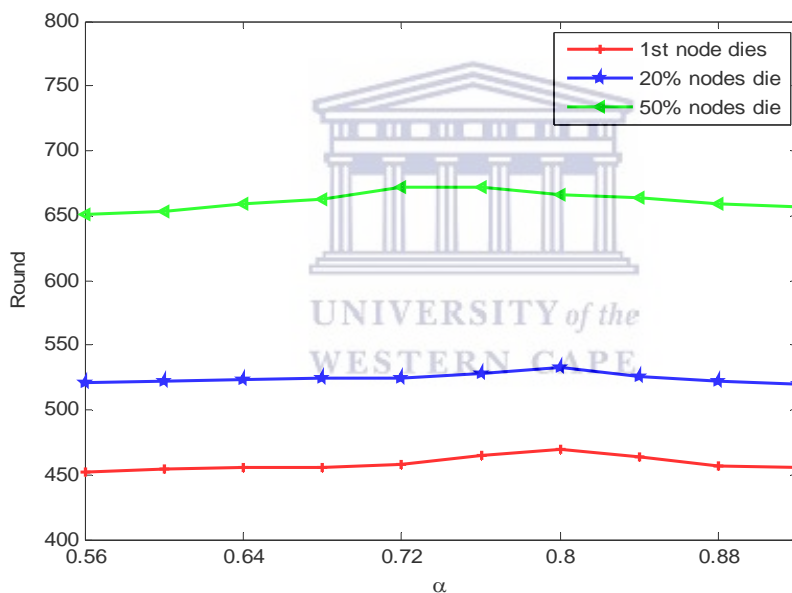

Figure 6.6: Effect of  $\alpha$  and  $\beta$  values on network lifetime

The performance of EOCIT protocol for different values of the energy parameter  $\alpha \in \{0,1\}$  is shown in Figure 6.7. The simulation runs stopped when 90% of the sensor nodes were dead. We noticed that EOCIT behaves as DECSA protocol by eliminating energy levels when the value of  $\alpha$  equals to 0. In addition, when the value of  $\alpha = 0.4$ , as depicted in the figure, its curve is higher than other curves. It has more sensor nodes alive in all the

network regions. Hence, this value for  $\alpha$  ( $\alpha = 0.4$ ) extends the sensor network lifetime more than the other values of  $\alpha$  in the range.

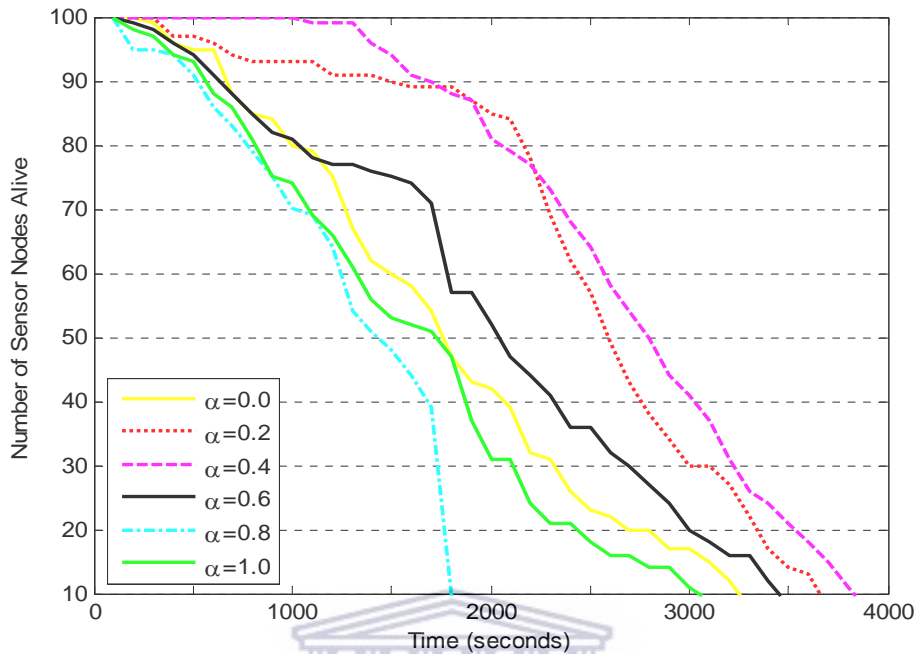

Figure 6.7: Number of sensor nodes alive varying in  $\alpha$  value

## 6.5 Energy consumption per round

Partitioning the sensor network into different clusters in which nodes in a cluster communicate with the cluster head and the cluster heads communicate with the base station, not only minimizes the energy consumption of sensor nodes but also maximizes the sustainability of the entire sensor network. However, the distance between the nodes and the base station determines the amount of energy consumption of the sensor nodes.

The performances of EOCIT, DECSA, and MOCRN protocols are compared in terms of energy consumption per round varying the number of clusters in the network. The results show that when there are fewer clusters in the network, more energy is dissipated because the nodes will transmit through long distance to their respective cluster heads. Moreover, it is observed that less energy is dissipated in all the protocols as the clusters increase after the optimal number of clusters in each protocol has been exceeded. Figure 6.8 shows that increasing the number of clusters beyond the optimal number do not significantly increase

the energy consumption per round in a network, since the nodes continue to transmit to their cluster heads through short distance within their transmission range; the extra cluster heads increase the sensor nodes' energy consumption. Among the three protocols, DECSA dissipated the highest energy while EOCIT dissipated the least amount of energy. The main reason for this is that our algorithm considered both the residual energy and the sensor nodes' location for the cluster heads selection while the MOCRN used only the distance and DECSA used the residual energy parameter for their cluster heads selection.

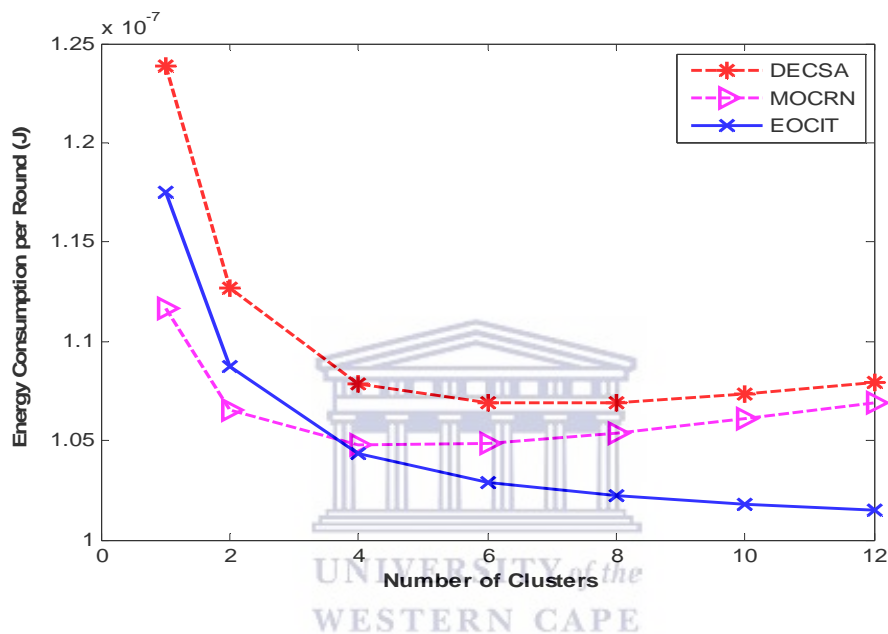

Figure 6.8: Energy consumption per round vs number of clusters

Energy dissipation in the range of clusters was carried out varying the distance between the cluster heads and the base station. Figure 6.9 shows the difference between the energy models. However, energy dissipation in the protocols is reduced as the distance between the cluster heads and the base station increases, as depicted in the figure. The reason is that as the distance between the cluster heads and the base station increases, more energy is dissipated during data transmission. Considering the number of nodes which increased from 100 to 500, the optimal number of clusters can be found by varying the distance between the cluster heads and the base station.

Conclusively, the results in Figure 6.8 and Figure 6.9 show that EOCIT performs better than MOCRN and DECSA protocols in terms of energy consumption.

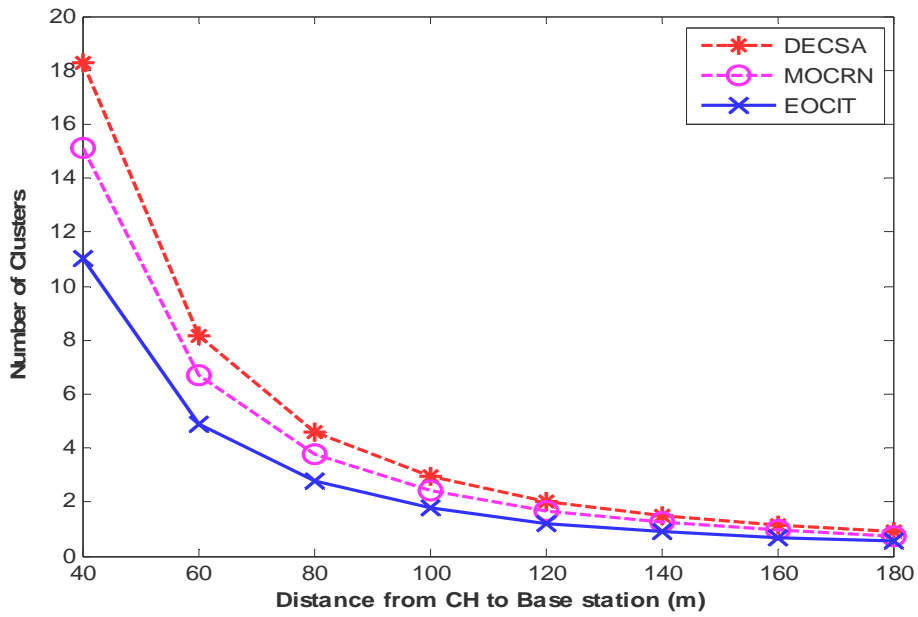

Figure 6.9: Distance from CHs to the base station vs optimal No. of clusters

Furthermore, we varied the distance from cluster heads (CHs) to the base station with a different number of clusters to determine the average energy dissipation per round for each protocol for  $\epsilon_{amp} = 0.0013 \text{ pJ/bit/m}^4$  and  $\epsilon_{fs} = 10 \text{ pJ/bit/m}^2$  as shown in Figure 6.10 to Figure 6.12.

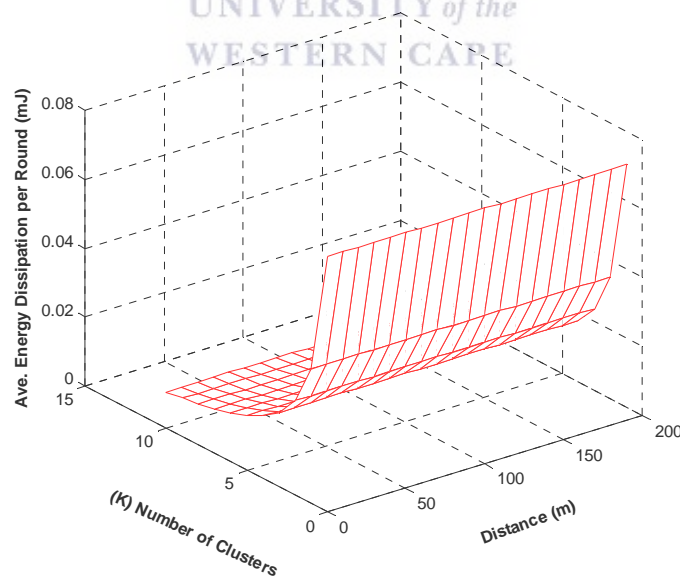

Figure 6.10: Average energy dissipation vs no. of clusters for DECSA energy model

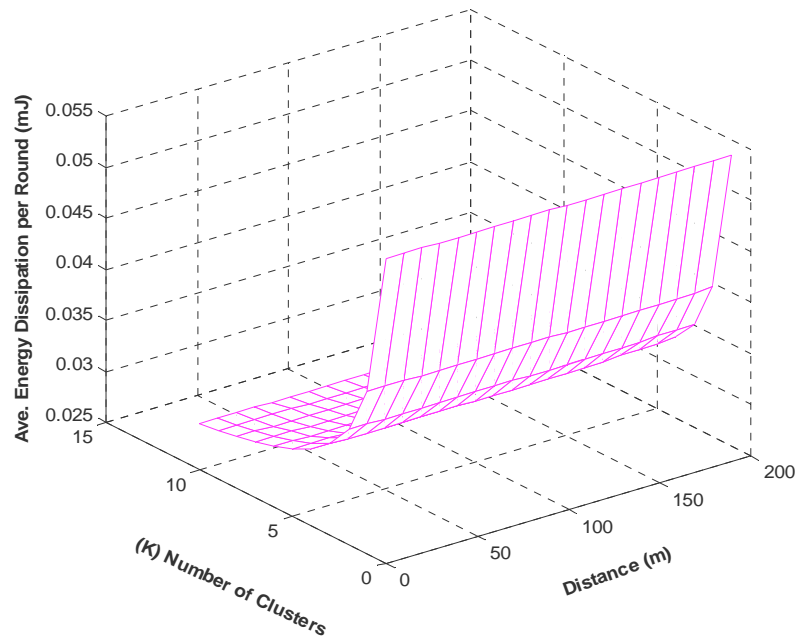

Figure 6.11: Average energy dissipation vs no. of clusters for MOCRN energy model

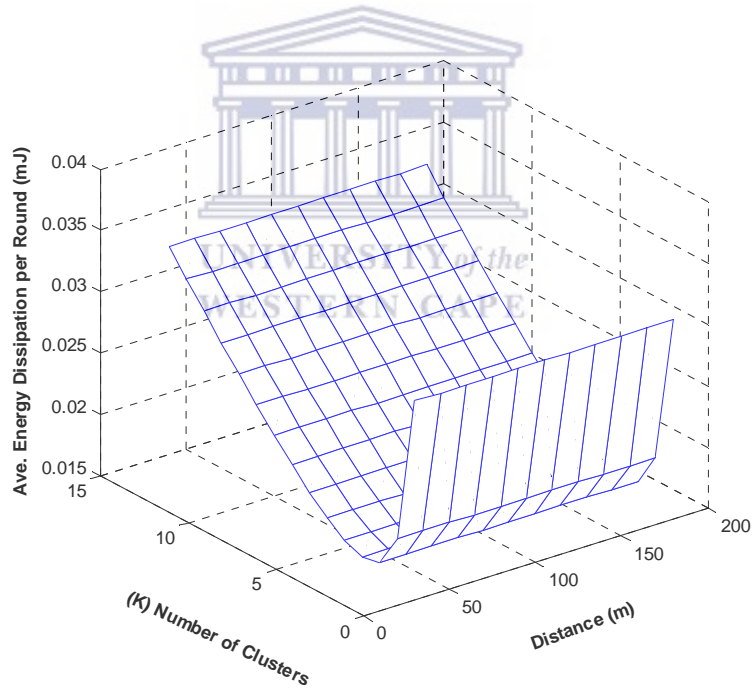

Figure 6.12: Average energy dissipation vs no. of clusters for proposed energy model

The above figures show the average energy dissipation for the three protocols, where EOCIT dissipated the least amount of energy.

Table 6.7 shows three different shapes which sensor nodes can use to form clusters. The shape of the network can be rectangular, circular, and hexagonal. The formula derived in section 4.7 is used to determine the optimal clusters ( $K_{opt}$ ) for a different number of sensor nodes  $V$ : 100, 200, 300, 400, and 500. The length/ radius of each shape is determined using the respective  $K_{opt}$  for network length  $M = 100m$ . The average length/radius of a rectangular, circular and hexagon shape is shown in columns three, four, and five respectively of the table. Interestingly, the result shows that as the number of nodes increases, the communication distance of each node in a cluster decreases using the same network area. The average number of data per bit transmitted by each node is reduced, increasing the sensor nodes' lifetime.

The values presented in the table can assist network designers to gain an idea about the average distance between a node and a cluster head for different network sizes.

Table 6.7: Shapes of sensor network for  $\epsilon_{fs} = 10pJ/bit/m^2$ ,  $M=100$  (Zhang et al., 2009).

| No of Sensor Nodes/ Network | Optimal No of Clusters ( $K_{opt}$ ) | Rectangular Cluster                     | Circular Cluster                             | Hexagonal Cluster   |
|-----------------------------|--------------------------------------|---|--|---|
|                             |                                      | Length = $\frac{M}{\sqrt{K_{opt}}}$ (m) | Radius = $\frac{M}{\sqrt{\pi(K_{opt})}}$ (m) | Length = $\frac{4M}{3\left(\sqrt{3(K_{opt})}\right)}$ (m) |
| 100                         | 4                                    | 50.00                                   | 28.21  | 38.49   |
| 200                         | 5                                    | 44.72                                   | 25.23  | 34.43   |
| 300                         | 7                                    | 37.80                                   | 21.32  | 29.10   |
| 400                         | 9                                    | 33.33                                   | 18.18  | 25.66   |
| 500                         | 10                                   | 31.62                                   | 17.84  | 24.34   |

### *Effect of Network Area on Sensor Network's Lifetime*

The effect of network area on a sensor network's lifetime is investigated as shown in Figure 6.13. We randomly distribute 100 sensor nodes, each node with an initial energy of 1J and the network area is varied from 100m x100m, 200mx200m, 300mx300m, 400mx400m, and 500mx500m. The base station is positioned outside the network area at coordinates (50,180)m, (100,230)m, (150,280)m, (200,330)m, and (250,380)m respectively. Other parameters used in the simulation are contained in Table 6.1. It is clear that as the network's area increases, the communication distance increases between the sensor nodes and the network lifetime is reduced. However, long distance data transmission is the major cause for energy consumption. Thus, EOCIT has a longer network lifetime and outperforms the MOCRN and the DECSA protocols. The appreciable longer network lifetime is as a result of the uniform distribution of cluster heads within the network. Conclusively, using the largest network area (i.e 500m x 500m), the network lifetime of EOCIT lasts longer by 69% than DECSA and 38% than MOCRN protocols.

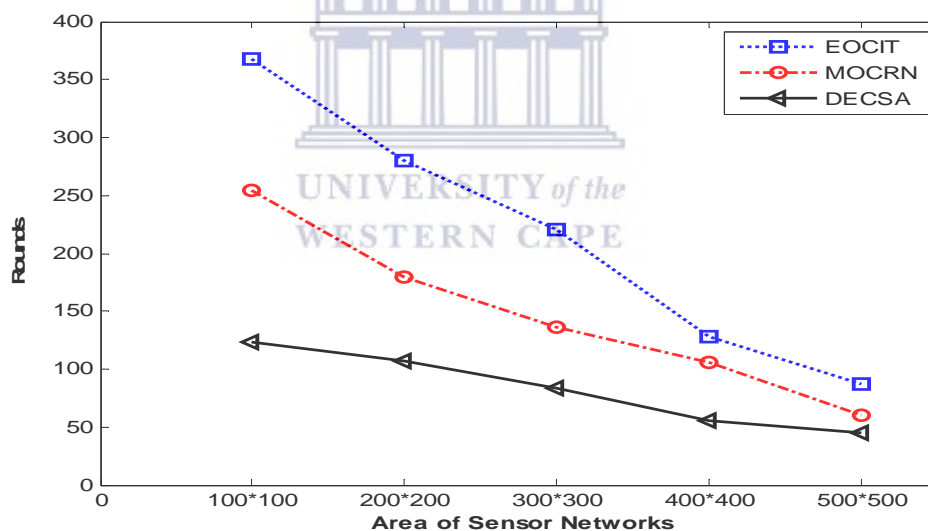

Figure 6.13: Effect of network area on sensor network's lifetime

### **6.6 Energy consumption in normal sensor network and hybrid nodes network**

In this section, energy consumption of two different networks is investigated: sensor nodes network (SN) and hybrid nodes network (HSN). HSN is an improvement on the proposed protocol by considering the service differentiation of the nodes for energy efficiency as



described in section 4.4. Each network consists of 100 randomly distributed nodes. In the first network, all the nodes are treated the same; each node with an initial energy of 1J making the total energy equals to 100J. The second network is the hybrid sensor network HSN consisting of 80 normal nodes and 20 hybrid nodes, where each hybrid node is 0.5J more than the energy of a normal node and the total energy for HSN is 110J. The average values of the simulation results obtained are used for the plotting of the figures. Energy dissipation in HSN is measured in two ways:

firstly when the EOCIT algorithm for HSN is not implemented and secondly when the HSN algorithm is implemented.

Initially, HSN performs better than the SN when the EOCIT algorithm was not applied. After about 20% of the energy has been dissipated, the performance of HSN is worse than SN as depicted in Figure 6.14. More energy is dissipated due to uneven energy distribution among the nodes in HSN. However, after 500th round, the network energy consumption improves more in HSN than the SN when the EOCIT-HSN algorithm is implemented.

The reason is that after half the number of rounds, most of the normal nodes SN have dissipated their energy while most of the HSN still have more residual energy than the normal nodes.

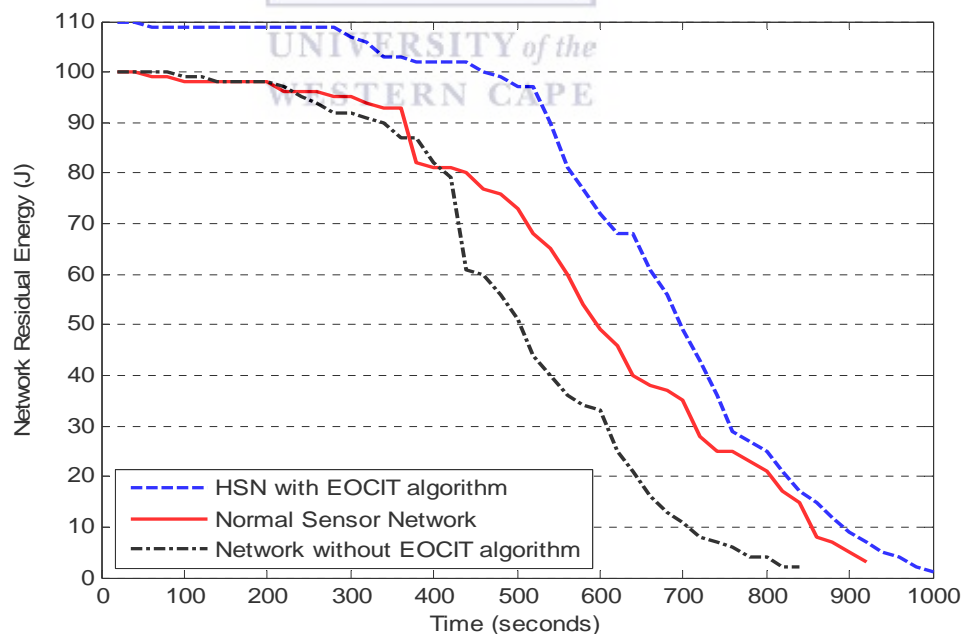

Figure 6.14: Comparison of energy dissipation of SN and HSN

## 6.7 Performance comparison of three different models

This section presents three different models used to determine the network lifetime. One hundred sensor nodes are randomly distributed in 100m x 100m sensor region. The network consists of 80 normal nodes and 20 hybrid nodes. Normal nodes and hybrid nodes are differentiated by their energy and service delivery as described in Table 4.2. The network lifetime of EOCIT is compared with DECSA and MOCRN protocols using the optimal number of clusters presented in Table 6.6 for each protocol.

### *First model for sensor network lifetime*

In the first model, EOCIT algorithm is implemented without giving any special consideration to the nodes, both the normal nodes and the hybrid nodes are treated equally and all the sensor nodes have the same initial energy. The initial energy of each node is 1J and the simulation time (round) runs for 1000 seconds. The average energy consumption of the nodes is taken every 100 seconds.

Figure 6.15 and Figure 6.16 show the number of live nodes for DECSA, MOCRN, and EOCIT protocols over the number of rounds.

A *round* is defined as an equal period of time every sensor node transmits its data packet to the base station. The position of the base station is varied to see the effect of communication distance between the nodes and the base station on the network lifetime. Initially, all the sensor nodes' batteries are full; each node with an initial energy of 1J. The receiving and sending power of each node is 0.360W and 0.395W respectively for receiving data based on energy consumption (Waltenegus Dargie and Christian Poellabauer, 2010). The same parameters are used for all the protocols. Table 6.1 contains the parameters used in the simulation.

We studied the lifetime of the entire sensor network of DECSA, MOCRN, and EOCIT protocols; they dissipate their energy slowly with time. The base station is first placed at the center of the network as shown in Figure 6.15. The first node dies (FND) at 332th round in DECSA, 391th round in MOCRN, and at 448th round in EOCIT.

Similarly, the last node dies (LND) at 728th round, 831th round, and 968th round in DECSA, MOCRN, and EOCIT respectively. It is observed that the difference between the lifetimes of the three protocols is not significant. This is due to the short communication distance between the nodes and the base station.

Now we change the location of the base station to outside the network area at coordinate (50,180)m. The energy of the three protocols depleted slowly as the number of rounds increases as shown in Figure 6.16. FND was depleted at 255th round in DECSA, at 298th round in MOCRN, and at 361th round in EOCIT.

Similarly, the LND was depleted at 556th round, at 746th round, and at 802th round in the DECSA, MOCRN, and EOCIT protocols respectively. In the two scenarios of the base station locations, EOCIT has the highest number of live nodes and prolongs network lifetime compared to DECSA and MOCRN protocols. EOCIT shows good energy balancing throughout the networks. The reason is that the method used for the sensor nodes' association for EOCIT is based on received signal strength (RSS) as discussed in section 4.1 while MOCRN is based on hop count and DECSA is based on distance. Sensor nodes in EOCIT protocol associate (belong) to a cluster head that incurs minimum energy dissipation.

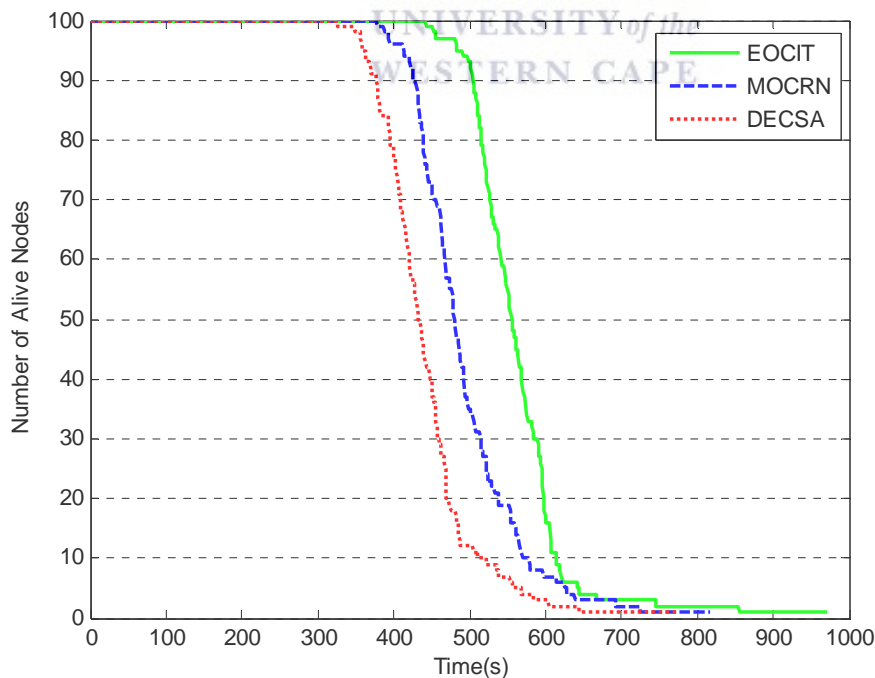

Figure 6.15: Live nodes vs time(s) when base station is at the center of the network area

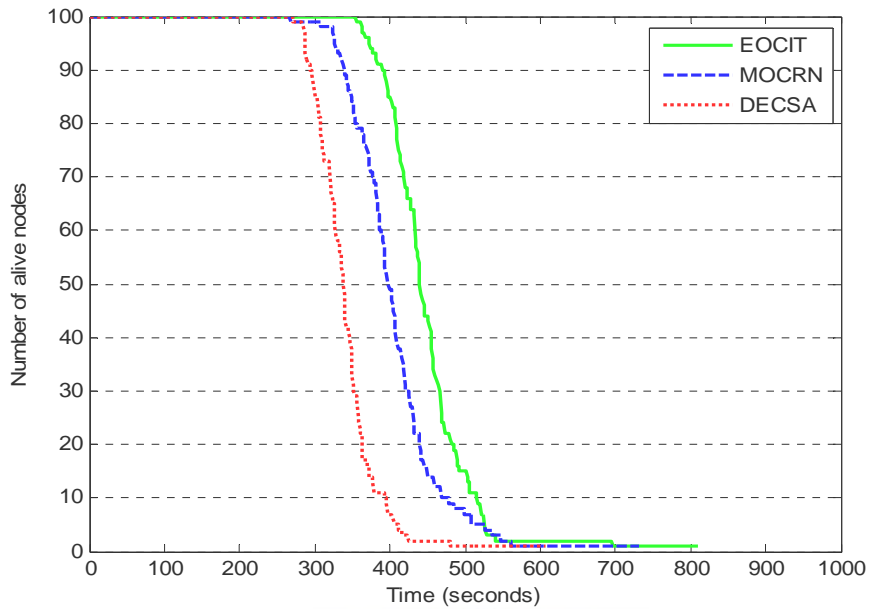

Figure 6.16: Live nodes vs time(s) when base station is outside the network area

Moreover, Figure 6.17 and Figure 6.18 are bar charts that indicate when the last node dies (LND) in each of the three protocols for the two base station locations. It can be seen from the two figures that EOCIT has the highest number of rounds before the last node dies. The reason is that our algorithms considered parameters such as the current energy of the sensor nodes, service differentiation, and the distance between the nodes during the election of new cluster heads. Hence, it performs better than the other two protocols.

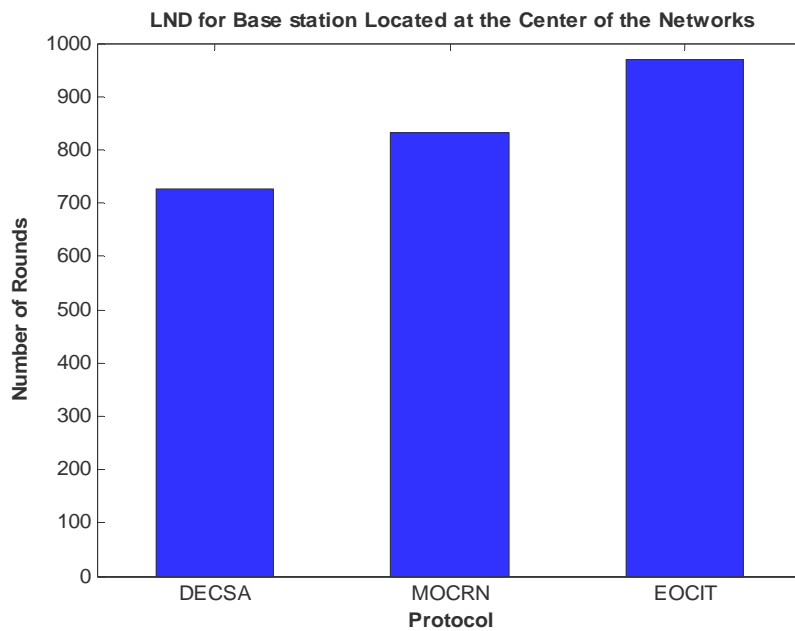

Figure 6.17: LND when the base station is located at the center of the network.

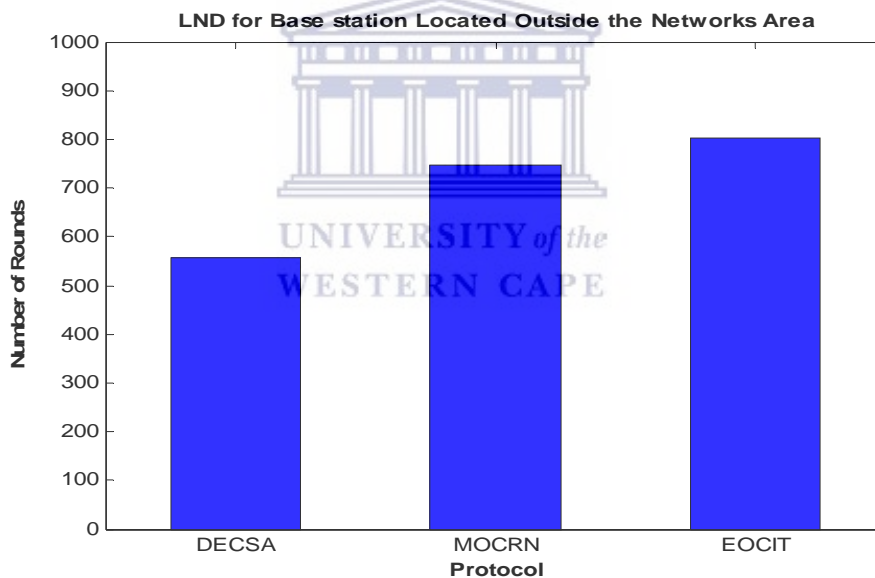

Figure 6.18: LND when the base station is located outside the network area

*Second model for sensor network lifetime*

The performance of the second model, EOCIT-MIX is evaluated here. Two algorithms were implemented to determine the network lifetime as shown in Figure 6.19. The network consists of 100 nodes randomly distributed, where 80 are normal nodes and 20 are hybrid

nodes. The total initial energy of normal nodes is 80J (i.e 80 nodes, 1J per node) while the hybrid nodes have a total initial energy of 30J (i.e 20 nodes, 1.5J per node). The base station is placed outside the network area at coordinate (50,180)m and simulation runs for 1000 rounds. Firstly, the EOCIT algorithm was implemented and runs for the first half of the simulation time (i.e 1 to 500 rounds). Its performance is compared with DECSA and MOCRN. The three protocols dissipate their energy slowly as the number of rounds increases. The performance of the three protocols during the first 500 rounds in this model is the same with the performance of the first model discussed above. The reason is that the algorithms and parameters used for the implementations are the same as the first model. Thereafter, we implement the EOCIT-HSN algorithm which runs for the next 500 rounds as shown in the figure indicated with the arrow. In this case, the energy and the service delivery of the hybrid nodes are taken into consideration. The result shows that EOCIT-HSN has more number of alive nodes than MOCRN and DECSA protocols. First node dies (FND) at 255th round in DECSA, at 298th round in MOCRN, and at 361th round in EOCIT. The FND is the same with what we obtained in the first model.

Similarly, the last node dies (LND) in DECSA at 555th round, 746th round in MOCRN, and 845th round in EOCIT when the EOCIT-HSN algorithm is implemented. The simulation results show that using EOCIT-HSN algorithm, the network lifetime increased by 52% more than DECSA and 13% more than MOCRN protocol. The reason for the improvement is that the hybrid nodes have more energy than the normal nodes. Thus, during cluster heads selection, they have a higher potential to be selected as cluster heads and if selected as cluster heads, they remain alive longer than the normal nodes.

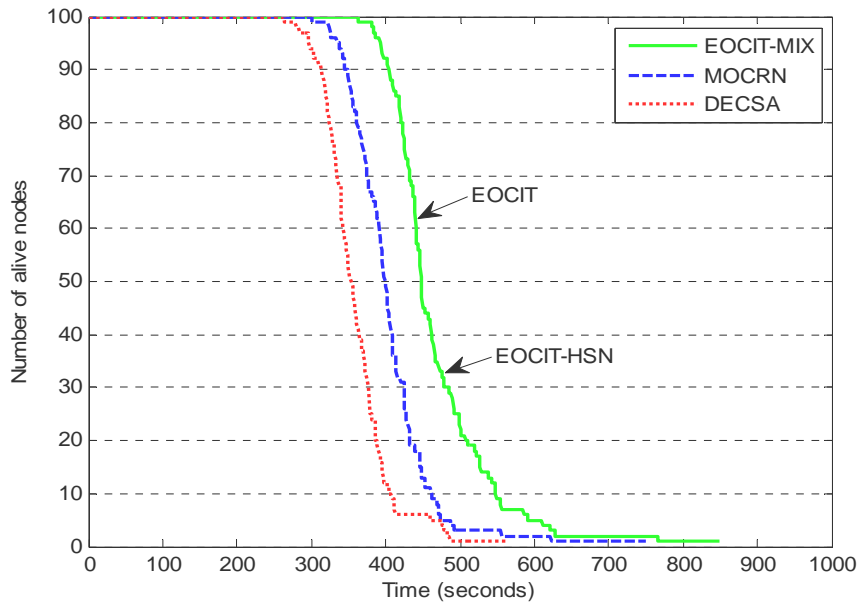

Figure 6.19: Energy dissipation in WSNs using EOCIT and EOCIT-HSN algorithms

### *Third model for sensor network lifetime*

In the third model, EOCIT-HSN algorithm is implemented and its performance is compared with DECSA and MOCRN protocols. In this case, two different network sizes: 100 sensor nodes and 500 sensor nodes are used to evaluate the performance of EOCIT-HSN algorithm. The same simulation parameters are used as above.

The first node dies (FND) at 255th round in DECSA, at 298th round in MOCRN, and at 382th round in EOCIT. Similarly, the last node dies (LND) at 555th round in DECSA, at 746th round in MOCRN, and 998th round in EOCIT.

The results show a significant improvement, EOCIT-HSN has higher number of alive nodes than DECSA and MOCRN as shown in Figure 6.20. Hence, it prolongs network lifetime compared to the results obtained in Figure 6.16.

The reasons are as follows

- EOCIT-HSN considered three parameters for the selection of the cluster heads: the residual energy, the position of the nodes in the network (distance-based) and service differentiation while DECSA used only residual energy to select cluster heads and MOCRN used distance.

- *Node association:* Sensor nodes in EOCIT associate (belong) to their cluster heads based on the received signal strength (RSS) while nodes in DECSA associate based on the distance between the nodes and nodes association in MOCRN is based on hop count.
- *Energy model:* Moreover, due to difference in the energy models used by the protocols is another important factor for difference in the network lifetime. We used the proposed energy model for the implementation while the two protocols used the energy model proposed in (Heinzelman et al., 2002) which assumed that all data packets transmitted by nodes are the same.
- In addition, cluster heads selected based on our algorithms avoid concentration of the cluster heads on the same side of the network.

We further increase the number of nodes from 100 to 500 nodes using the same network area of 100m x 100m. The network contains 400 normal nodes and 100 hybrid nodes. The optimal number of clusters obtained for each protocol for 500 nodes in section 6.2 is used for the implementation. The simulation runs for 4500 rounds. The first node dies (FND) at 321th round in DECSA, at 482th round in MOCRN, and at 713th round in EOCIT. Similarly, the last node dies (LND) at 3154th round in DECSA, at 3857th round in MOCRN, and at 4371th round in EOCIT as shown in Figure 6.21. EOCIT has greater number of alive nodes. Thus, it addresses the problem of energy imbalance in the network and performs better than DECSA and MOCRN protocols. Hence, it extends the network lifetime, particularly for large networks.

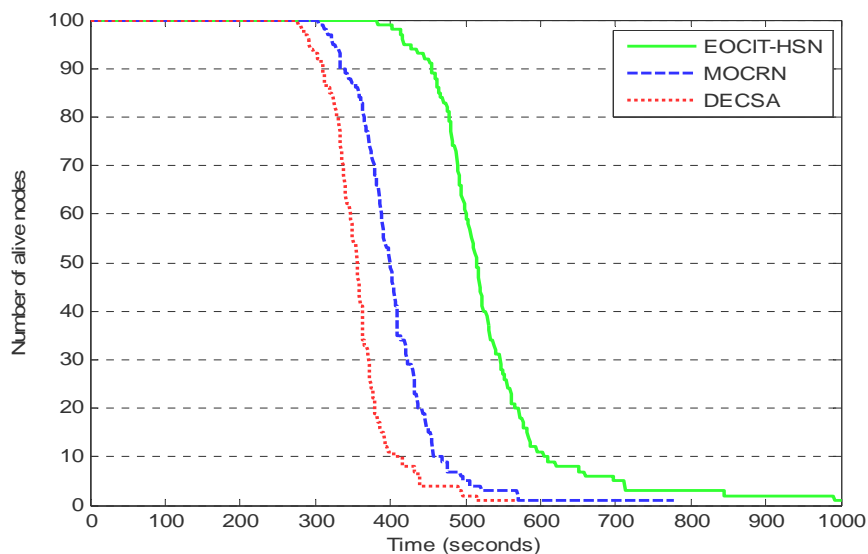



Figure 6.20: Sensor nodes lifetime with 80 sensor nodes and 20 Hybrid nodes

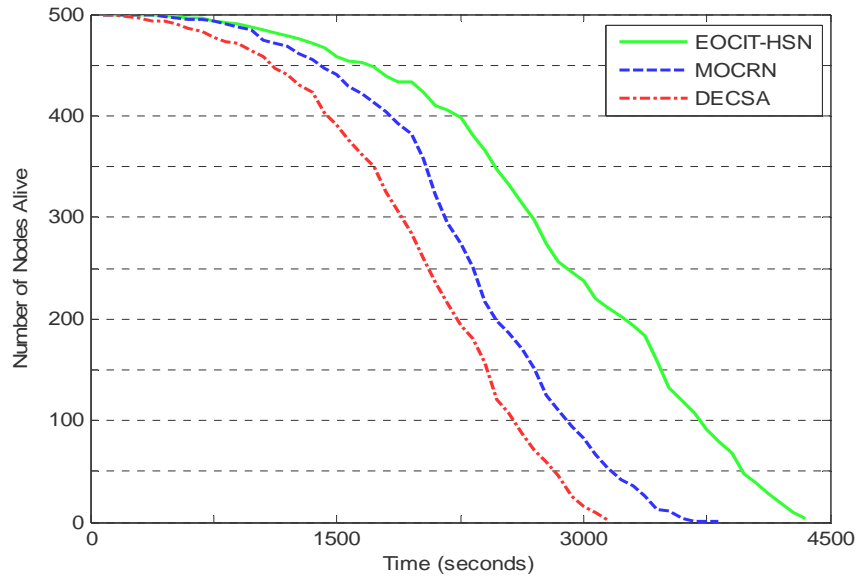

Figure 6.21: Sensor nodes lifetime with 400 sensor nodes and 100 Hybrid nodes

Figure 6.22 shows the moment in time until the last node dies in each of the protocols for the different number of nodes ranging from 100 to 500. The standard deviation across random topologies for each protocol is shown by the error bars. All the error bars are calculated at 95% confidence interval. It shows the variance between the energy levels on all the sensor nodes.

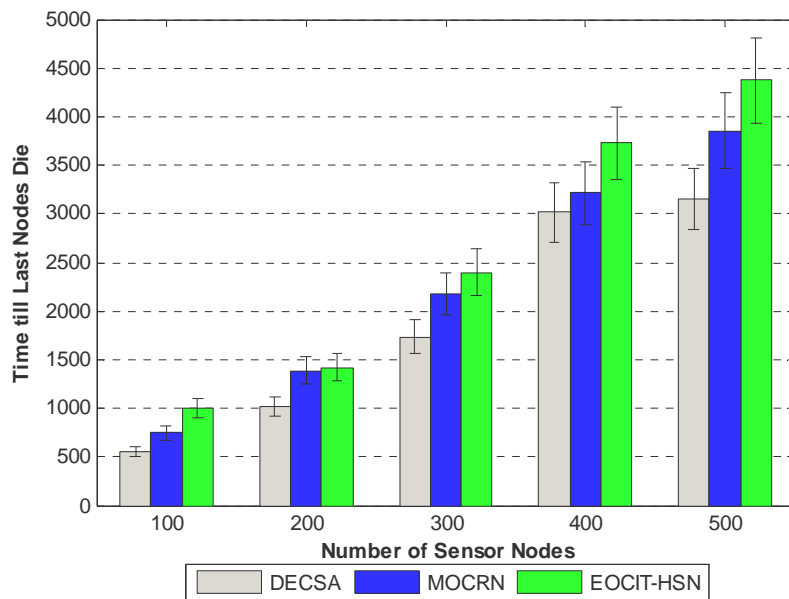

Figure 6.22: Network lifetime varying the network size from 100 nodes to 500 nodes

Figure 6.23 shows the comparison of the three models (i.e EOCIT, EOCIT-MIX and EOCIT-HSN). The performance of EOCIT and EOCIT-MIX are the same for the first 500 rounds of the simulation because the same model was used for the implementation. However, after the first 500 rounds when the EOCIT-HSN algorithm is implemented, the network has greater number of alive nodes than when it was not implemented. Thus, EOCIT-HSN has the highest number of alive nodes among the three models as discussed above.

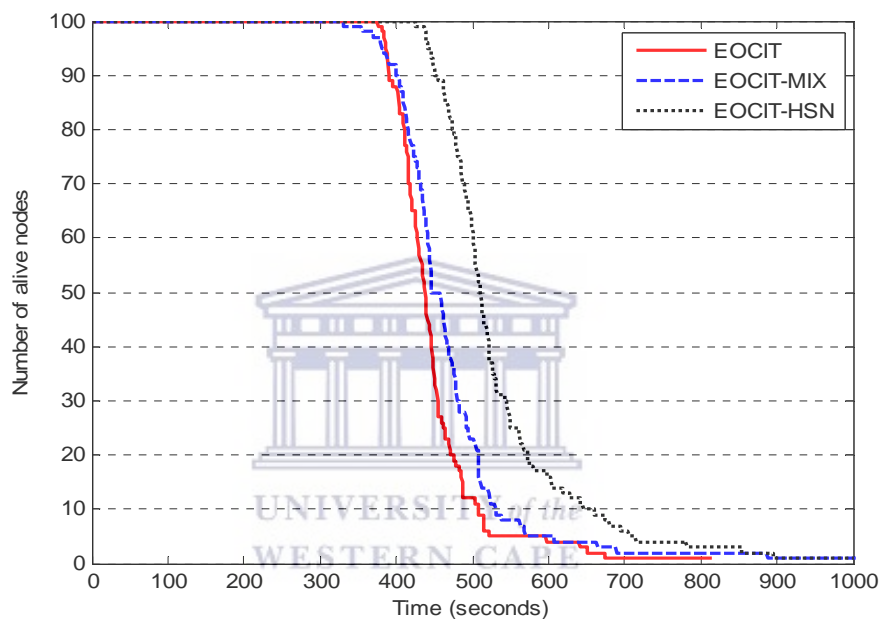

Figure 6.23: Comparison of the number of alive nodes in the three models

### *Energy Dissipation in EOCIT*

Figure 6.24 shows the energy dissipation of normal nodes and hybrid nodes in EOCIT consisting of 80 normal nodes and 20 hybrid nodes. The total initial energy of normal nodes is 80J and 30 J for hybrid nodes. Both the normal nodes and hybrid nodes dissipate their energy slowly with the increase in rounds. We can see that between 340 to 602 rounds, hybrid nodes dissipate more energy than the normal nodes. The reason is that during the initial cluster heads selection, hybrid nodes have more potential to be selected as cluster heads than the normal nodes due to their high energy. Thus, being a cluster head

dissipates more energy; while the normal nodes have greater number of live nodes. However, after 602th round, hybrid nodes have greater number of live nodes because they have more residual energy than normal nodes.

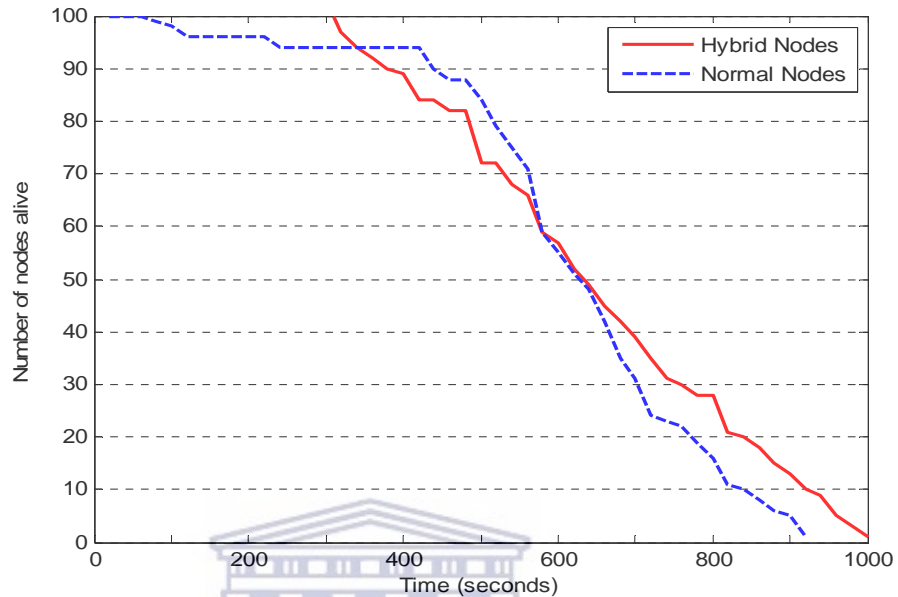

Figure 6.24: Number of nodes alive in normal and hybrid nodes

#### *Energy Dissipation in EOCIT-MIX and EOCIT-HSN*

The same simulation setup used above is for this implementation. The EOCIT-MIX and EOCIT-HSN algorithms are both implemented over a network of 100 nodes to determine the amount of residual energy in each scheme as shown in Figure 6.25. It is observed that the residual energy of the nodes in EOCIT-MIX is higher than EOCIT-HSN after 900 rounds. The reason is that during the first 500 runs, the energy of the hybrid nodes is preserved. The energy of EOCIT-MIX is only considered in the next 500 ( i.e 501 to 1000) rounds. On the other hand, in EOCIT-HSN the energy of the hybrid nodes is considered from the start of the simulation. There is a high probability of selecting hybrid nodes as the cluster heads before normal nodes are selected as cluster heads. In the light of this, EOCIT-HSN dissipates more energy and the normal nodes in EOCIT-MIX have more residual energy as depicted in the figure.

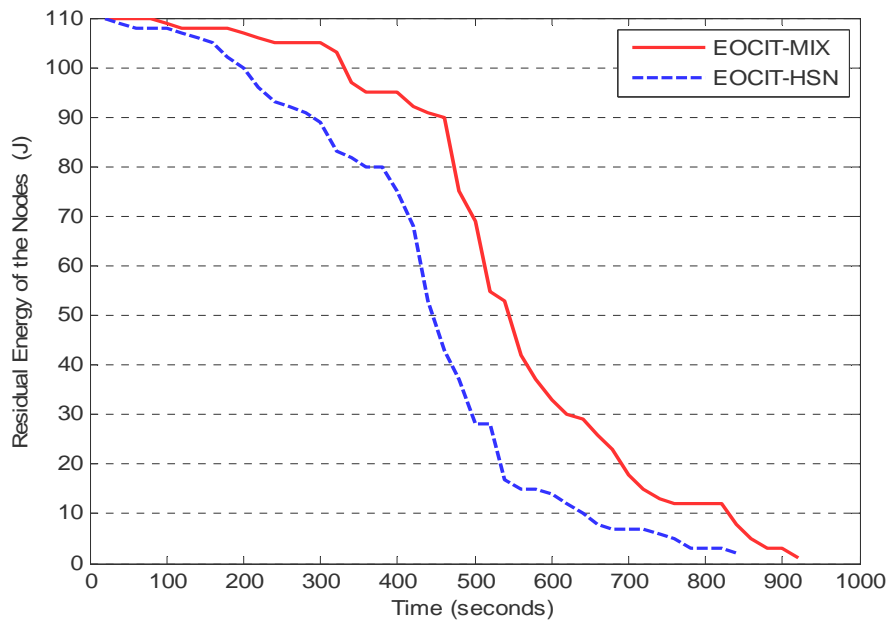

Figure 6.25: Residual energy of EOCIT-HSN and EOCIT-MIX

### 6.8 Energy dissipation varying the number of cluster heads

We use the same number of nodes (100 sensor nodes) while the base station is positioned at the coordinate (50,180)m from the center of the network, while varying the number of cluster heads to see their effect on the energy dissipation in the network. Initially, there is no significant difference in the energy dissipation when the network contains three cluster heads and five cluster heads as shown in Figure 6.26. However, after 325 rounds, the network with five cluster heads dissipated more energy than the network with three cluster heads while the network containing nine cluster heads dissipated the most energy. It is observed that as the number of cluster heads increases, energy dissipation in the network likewise increases as shown in the figure. The reason is that cluster heads consume more energy than non-cluster head nodes. The greater the number of cluster heads in the network, the more the energy consumption, resulting in a shorter lifetime of hybrid sensor networks.

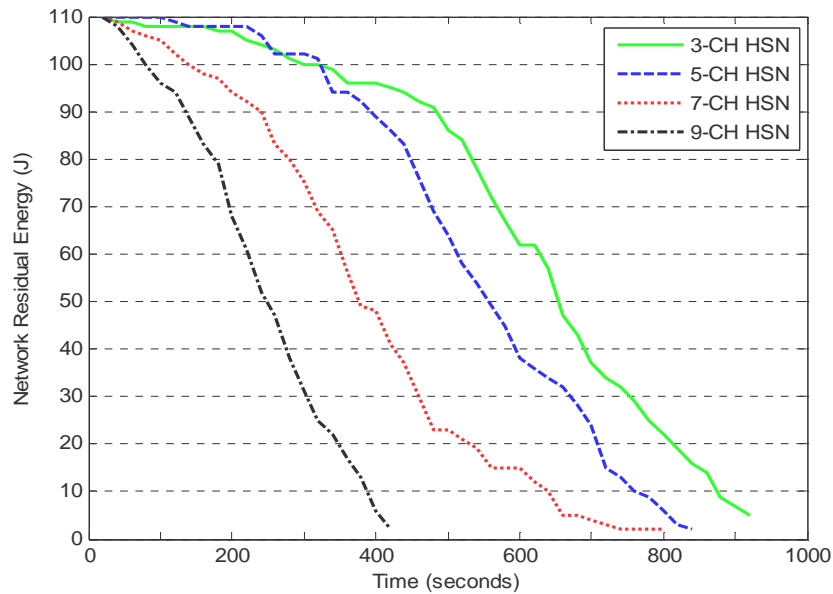

Figure 6.26: Energy dissipation of HSN vary the number of cluster heads

#### *Average Network Lifetime*

The Linear Programming LP model formulated in section 4.9 is used to determine the network lifetime of the sensor nodes. Sensor nodes are randomly distributed over 100m x100m sensor field and the number of nodes range from 100 to 500.

We considered two different base station locations for the simulation. The position of the cluster head is significant for two reasons: firstly, the routing overhead inside the cluster changes with the cluster head location. Secondly, it affects the energy consumption in the cluster for data aggregation and routing.

The first base station is placed at the coordinate (50, 50)m of the network and the second base station is located outside the sensor network region at the coordinate (50, 180)m.

The simulation runs for 80 random topologies for each network size 100, 200, 300, 400 and 500 sensor nodes to ensure consistency of the results and is averaged. The average values are used for the plotting of the graphs. The parameters used in the simulation are contained in Table 6.1. The linear programming model is solved with the ILOG CPLEX 12.0 Studio optimization (CPLEX, 2011). The computations are executed on Pentium(R) Dual Core Processor 2.3GHz 32-bit, and 4GB of RAM on Windows 7.

Our main interest in these experiments is to determine the average lifetime of the sensor networks in each of the protocols. The results obtained for each of the protocols for the two base station locations are shown in Figure 6.27 and Figure 6.28. The standard deviation SD for each bar represented by the symbol “ I ” placed on top of each bar was determined. The standard deviation gives the average variance between energy levels on all sensor nodes.

#### ***Base station located at the center of the network***

The average network's lifetime achieved by EOCIT for 100 sensor nodes is 10.8% higher than DECSA and 2.4% higher than MOCRN when the base station is located at the centre of the network. Moreover, EOCIT is 23.7 % higher than DECSA protocol and 5.3% higher than MOCRN protocol when the number of nodes is increase to 500 as shown in Figure 6.27.

#### ***Base station located outside the network area***

Figure 6.28 shows the graph for different network sizes when the base station is located outside the network area at the coordinate (50, 180)m. The average network lifetime achieved by EOCIT is 17.4% and 9.2% higher than DECSA and MOCRN protocols respectively for a network size of 100 sensor nodes. However, when the number of nodes is 500, EOCIT is 18.2% higher than DECSA and 11.6% higher than MOCRN protocols. EOCIT has the highest average lifetime compared to DECSA and MOCRN protocols. It performs better in the two scenarios of the base station locations than DECSA and MOCRN protocols as shown in the both figures. The reason is that sensor nodes are able to communicate with their cluster heads through a short distance due to uniform distribution of cluster heads within the network. In addition, energy dissipation by each sensor node during transmission is proportional to the  $q_i$  bits sensed data and sensor nodes that are not transmitting or receiving any data go into sleep state.

Finally, the method used for the selection of cluster heads considered node location and the residual energy of the nodes while DECSA selects cluster heads based on residual energy only and MOCRN is based on distance. Thus, EOCIT outperforms DECSA and MOCRN protocols.

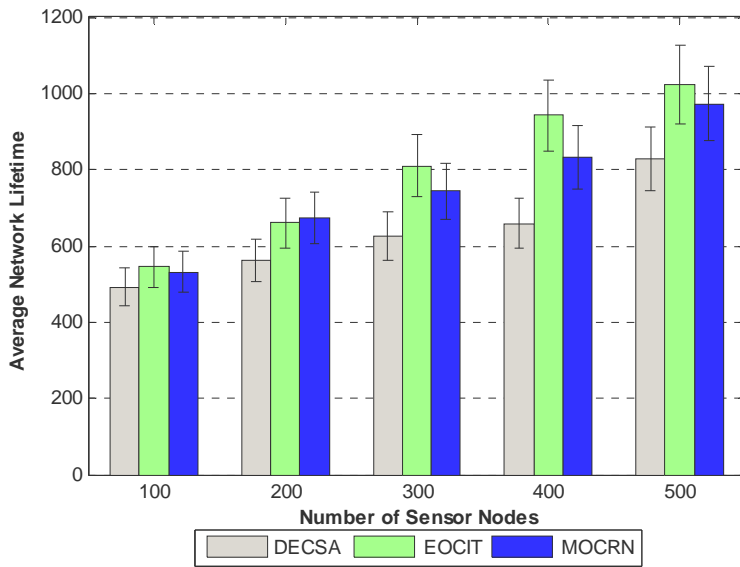

Figure 6.27: Average network Lifetime when base station is located at the center of the network

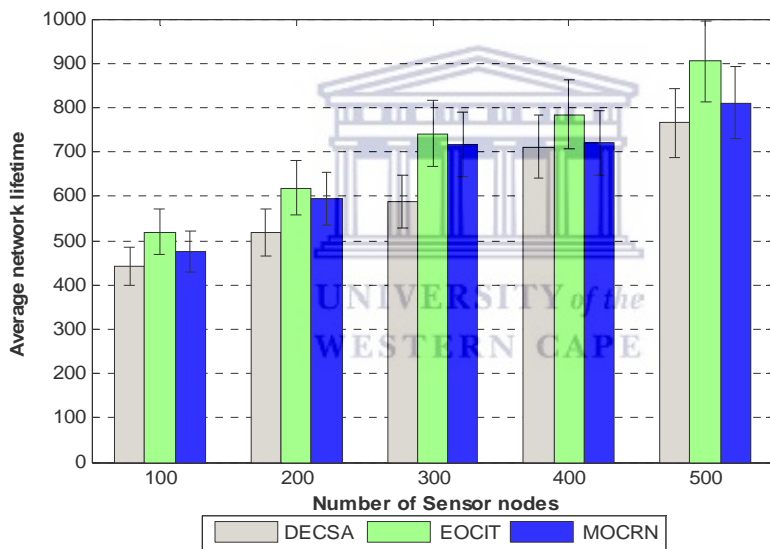

Figure 6.28: Average network lifetime when base station located at outside the network area

### End-to-end packets delay

The performance of end-to-end packets delay for the three routing protocols during simulation time is analyzed as shown in Figure 6.29. Packet delay means the difference between the time taken for data packets to reach the destination minus the initial time of the packets. The number of nodes ranging from 100 to 500 is considered for the simulation. In DECSA and MOCRN protocols, as the number of sensor nodes increases the packets delay likewise increases. In EOCIT protocol, as the number of sensor nodes increases, the packets delay slowly increases. However, after 300 nodes EOCIT has the lowest packets delay among the three protocols. The reason is that cluster heads in EOCIT are uniformly distributed within the network and nodes transmit to their respective cluster heads over a short distance. In addition, the nodes are able to select a node with more residual energy and finally, a node with fewer amounts of data is selected as the relay node, minimizing the waiting time of a data packet during transmission.

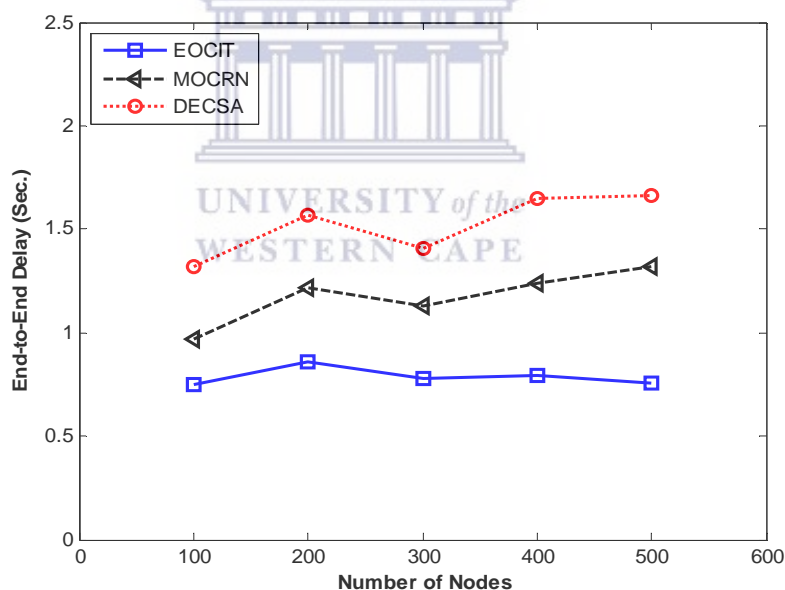

Figure 6.29: Number of nodes vs end-to-end delay



### Throughput

Figure 6.30 shows the throughput of DECSA, MOCRN, and EOCIT protocols obtained from the simulation results varying the number of nodes. We can see that as the number of the nodes increases, the throughput for each protocol likewise increases. The results show that EOCIT has a higher throughput compared to DECSA and MOCRN protocols. The reason is that EOCIT considered the minimum separation distance between the cluster heads and the residual energy of the relay nodes during communication.

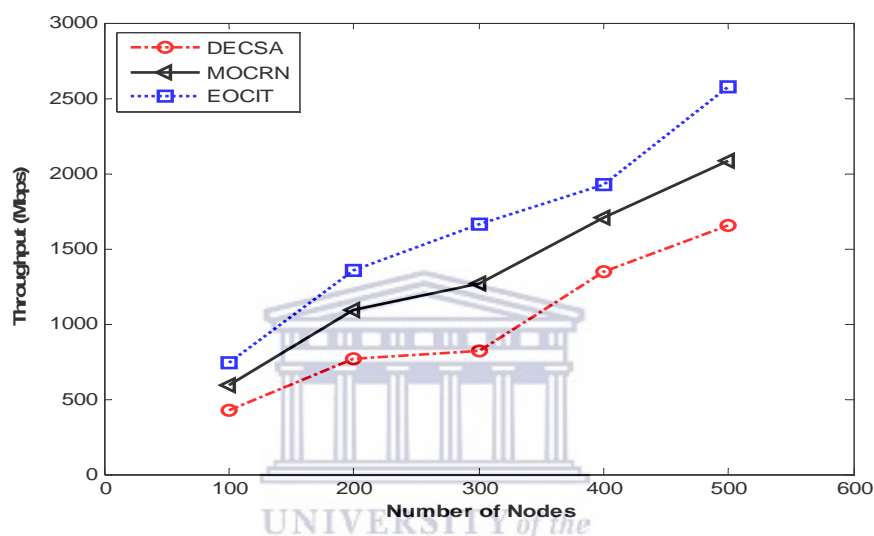

Figure 6.30: Number of nodes vs throughput

### Packet delivery ratio

Figure 6.31 shows the data packets delivery ratio for DECSA, MOCRN, and EOCIT protocols. In EOCIT protocol, as the density of the nodes increases, there are more nodes available for data transmission and this increases the data delivery ratio. However, packet delivery rates for MOCRN and DECSA is less as the sensor nodes increase. Data packets delivery rate for EOCIT is maintained throughout the simulation period. The relay nodes are selected based on the residual energy of the nodes and the position of the nodes in the network from the base station location. Obviously, EOCIT protocol outperforms DECSA and MOCRN protocols.

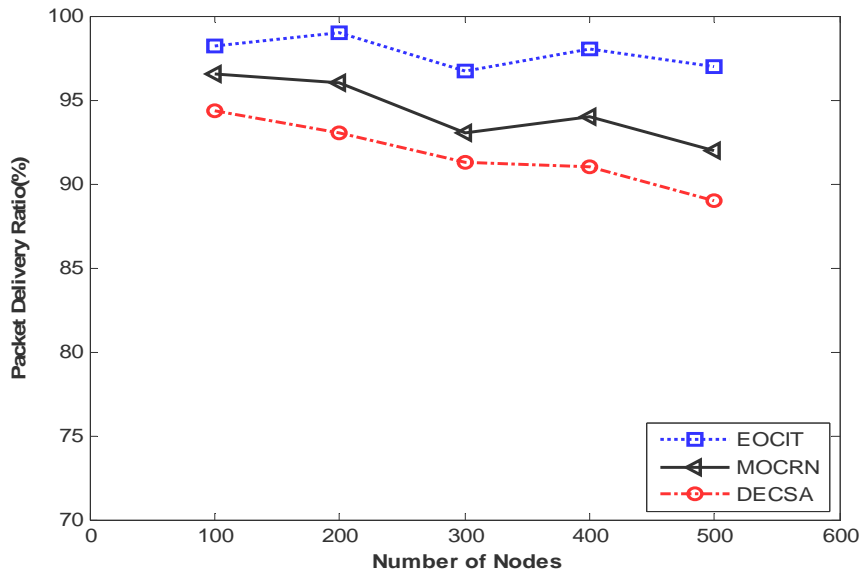

Figure 6.31: Packet delivery ratio vs number of nodes

## 6.9 Performance evaluation of service-aware energy model

The performance of the service-aware energy model proposed in section 3.3 is evaluated through simulation.  $V = 100$  sensor nodes are randomly distributed and deployed in a sensor network of length  $M = 100, 200,$  and  $500$  meters. The initial energy of each normal node is 1Joule. We use the same algorithm developed for the proposed protocol with some small modifications. The main aim is to maximize the network lifetime. A fraction of nodes are assigned with a specific amount of energy for advanced nodes. Let  $p$  be the fraction of advanced nodes having  $h$  more than the initial energy of a normal node and  $K$  is the number of cluster heads. If  $p = 0.04$  and  $h = 3$  then  $K = Vp$  (i.e  $K = 4$ ); the initial energy of the advanced node is 3Joules,  $V$  is the number of sensor nodes and each normal node,  $V(1 - p)$  is equipped with initial energy 1Joule at the beginning of the simulation. Each sensor node transmits 4000 bits data per round to its cluster head CH. The value of  $K$  is varied from 1 to 10; as the value of  $K$  increases, the average number of clusters likewise increases and when  $K = 10$ , it corresponds to direct transmission.

Figure 6.32 shows the expected number of rounds the sensor network can last against number of clusters by varying the number of clusters.

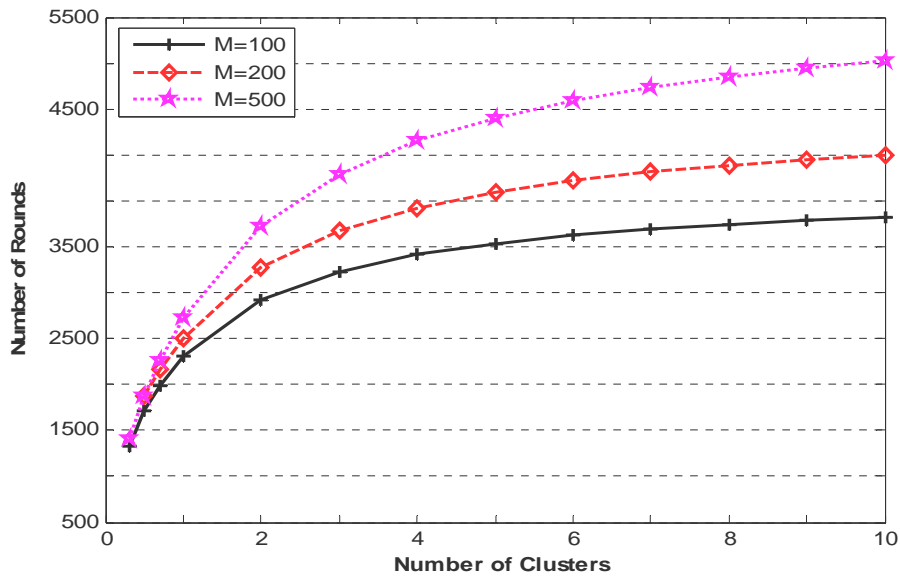

Figure 6.32: Expected number of rounds vs no. of clusters when varying values of  $\alpha$  and  $M$

Figure 6.32 shows clearly knee corresponding to  $K$  between 3 and 7; it reaches maximum and remains constant when  $K = 10$ . The optimal number of clusters is determined at the bend in the curve. The actual number for  $K$  varies, depending on the location of the receiver. We noticed that varying the network length  $M$  do not significantly change the shape of the curves. After the optimal number of clusters has been exceeded, increasing the number of clusters leads to more energy consumption. Therefore, increasing the number of clusters beyond the optimal number of clusters will not prolong the sensor networks' lifetime. Moreover, we extend the experiments to determine the network lifetime by placing the base station at coordinate (50m, 180m) of the network. The proposed EOCIT protocol is compared with EECH, EDFCM, and EEPCA protocols.

The following were assumed.

- (i) When the energy of a sensor node is equal to zero, the node is considered dead.
- (ii) When the alive sensor nodes within the network are less than or equal to 4, that is 96 sensor nodes are dead, and we therefore consider the whole network to be dead and no longer functioning.

Table 6.8 contains the values of network lifetime obtained for the four heterogeneous protocols considered using these metrics: first node dies (FND), half of the nodes die (HND), and last node dies (LND). Figure 6.33 shows the simulation results of the

networks. The number of alive nodes was plotted against time for  $p=0.04$  and  $h=3$ . The protocols have a different number of alive nodes after a certain number of rounds. For EOCIT protocol, FND increased by 44%, HNA by 45% and LND by 96% more than EECH protocol. For FND, a 42% improvement is achieved comparing EOCIT to EDFCM protocol, HNA improves by 32% and LND improves by 40%. Lastly, for EOCIT algorithm FND increased by 14%, HNA by 21%, and LND by 20% more than EEPCA protocol. For FND, EOCIT achieved 44% improvement compared to EECH and HNA improves by 45%. Moreover, EOCIT improves by 42% and 14% for FND compared to EDFCM and EEPCA respectively while 32% and 21% improvement is achieved for HNA by EOCIT over EDFCM and EEPCA respectively.

Table 6.8: Network lifetime for different heterogeneous protocols for  $p=0.04$  and  $h=3$

| Protocol | FND  | HNA  | LND  |
|----------|------|------|------|
| EECH     | 1222 | 1594 | 1927 |
| EDFCM    | 1235 | 1749 | 3014 |
| EEPCA    | 1542 | 1905 | 3526 |
| EOCIT    | 1756 | 2304 | 4227 |

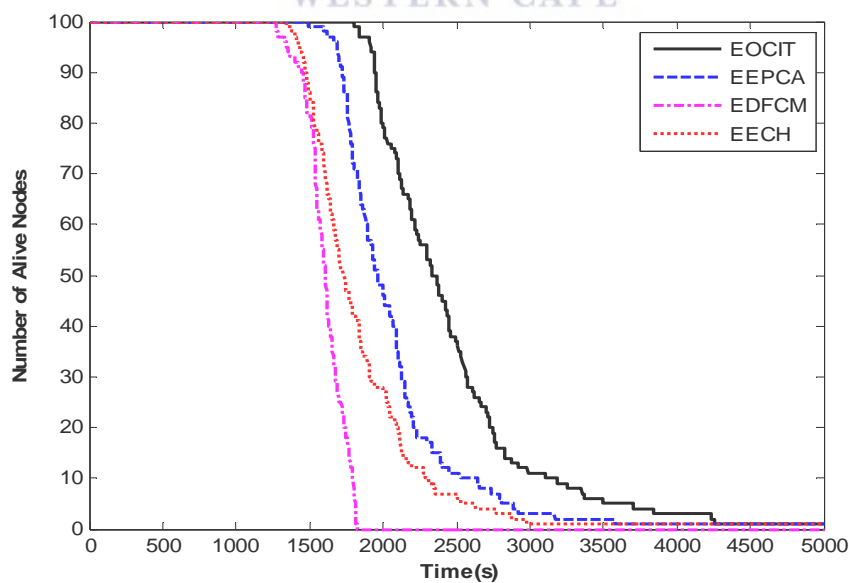

Figure 6.33: Number of alive nodes vs time(s) when  $p=0.04$  and  $h=3$

Similarly, the values of  $h$  and  $p$  were varied to obtain a new network lifetime. We set  $h = 5$  and  $p = 0.1$ . After simulation, new values for the network lifetime for each heterogeneous protocol were obtained and presented in the Table 6.9 while the graph is shown in Figure 6.34. For EOCIT, FND increased by 75%, HNA by 38% and LND by 87% more than EECH protocol. For FND a 42% improvement is achieved while comparing EOCIT algorithm to EDFCM protocol, HNA improves by 17% and LND improves by 17%. For EOCIT algorithm FND increased by 35%, HNA by 10%, and LND by 5% more than EEPCA protocol.

The results show that EOCIT is more stable and prolongs lifetime before the first node dies compared to other three protocols. The stability of EOCIT is because the advanced nodes (cluster heads) are more evenly distributed than other protocols and die more slowly than normal nodes.

Table 6.9: Network lifetime for different heterogeneous protocols for  $p=0.1$  and  $h=5$

|       | <b>FND</b> | <b>HNA</b> | <b>LND</b> |
|-------|------------|------------|------------|
| EECH  | 785        | 1104       | 1374       |
| EDFCM | 962        | 1301       | 2193       |
| EEPCA | 1015       | 1392       | 2458       |
| EOCIT | 1370       | 1526       | 2572       |

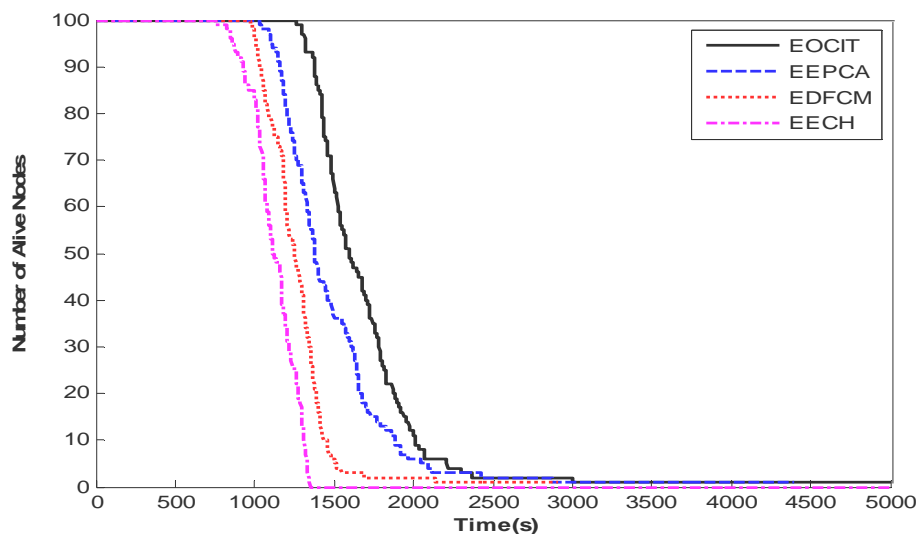

Figure 6.34: Number of alive nodes vs time(s) when  $p=0.1$  and  $h=5$

Moreover, we further increase the fraction of nodes which have been selected to be cluster heads by varying  $p$  from 0.1 to 1.0 and the energy of the cluster head  $h$  from 0.5 to 5.0. Figure 6.35 and Figure 6.36 show the number of rounds reached before the first node dies when varying the two parameters. We noticed that by increasing the total energy as a result of increasing  $p$  and  $h$ , the EECH protocol is not significantly affected. The stability period of EECH was almost constant in the whole process. However, EOCIT remains stable for a longer period than EDFCM and EEPKA before the first node dies.

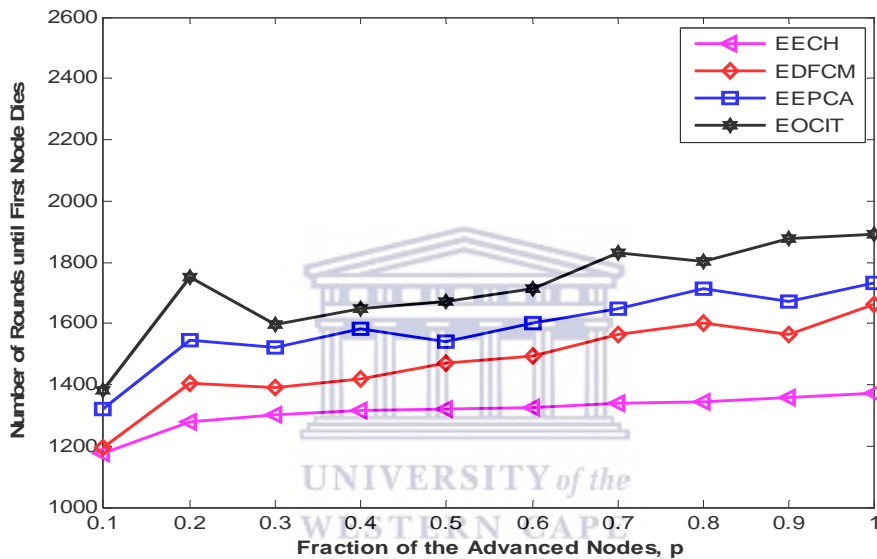

Figure 6.35: Number of rounds until first nodes dies vs Fraction of the advanced nodes  $p$

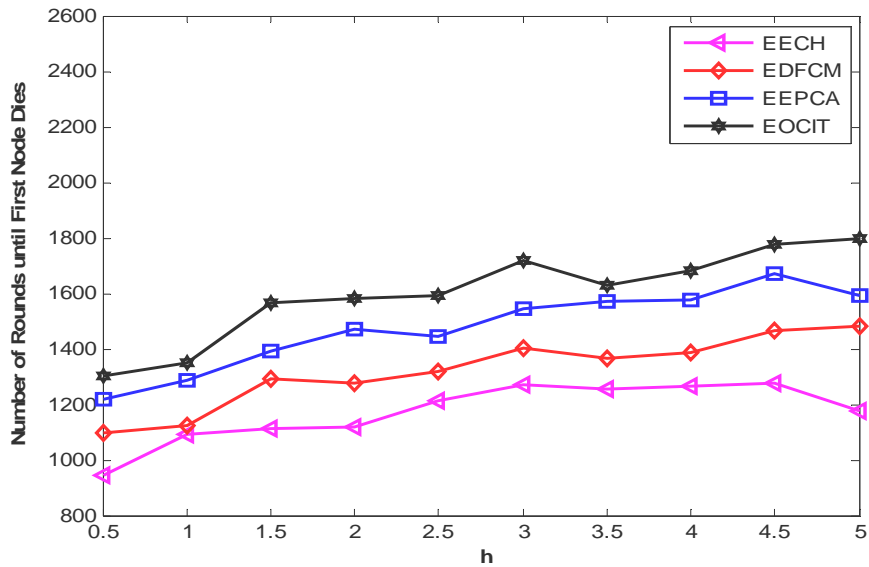

Figure 6.36: Number of rounds until first nodes die varying the value of  $h$

Figure 6.37 and Figure 6.39 show the number of rounds until 10% of the nodes die varying the value of  $p$  and  $h$  respectively. We can see that EEPKA is more stable than EECH and EDFCM because it is an energy aware protocol, which selects cluster heads based on the residual energy of the alive nodes. Thus, EOCIT being an energy aware, distance-based and service differentiation protocol; outperforms the three protocols.

The bar charts in Figure 6.38 and Figure 6.40 show when the last nodes die (LND), the time 10% of sensor nodes in the network die varying the value of  $p$  and  $h$  respectively.

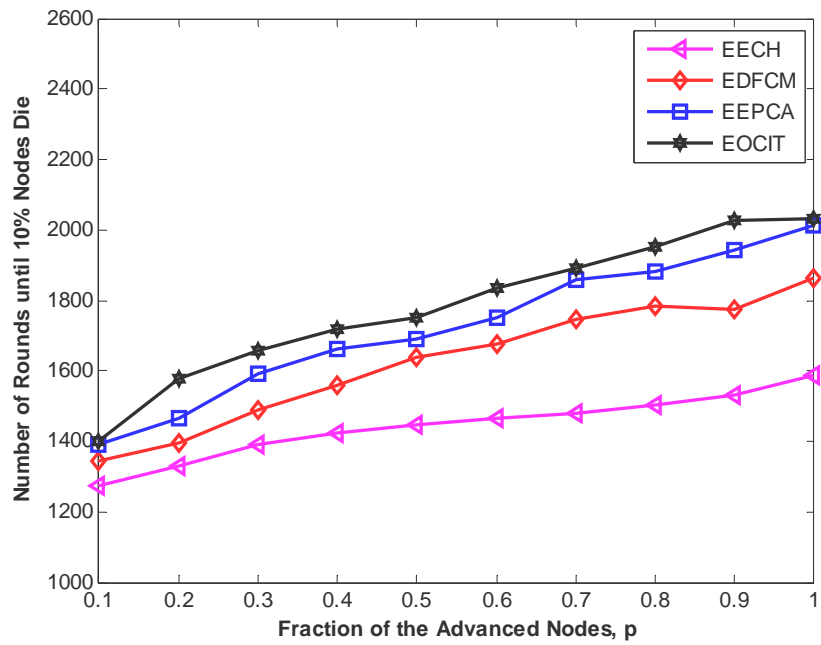

Figure 6.37: Number of rounds until 10% nodes die varying the value of p

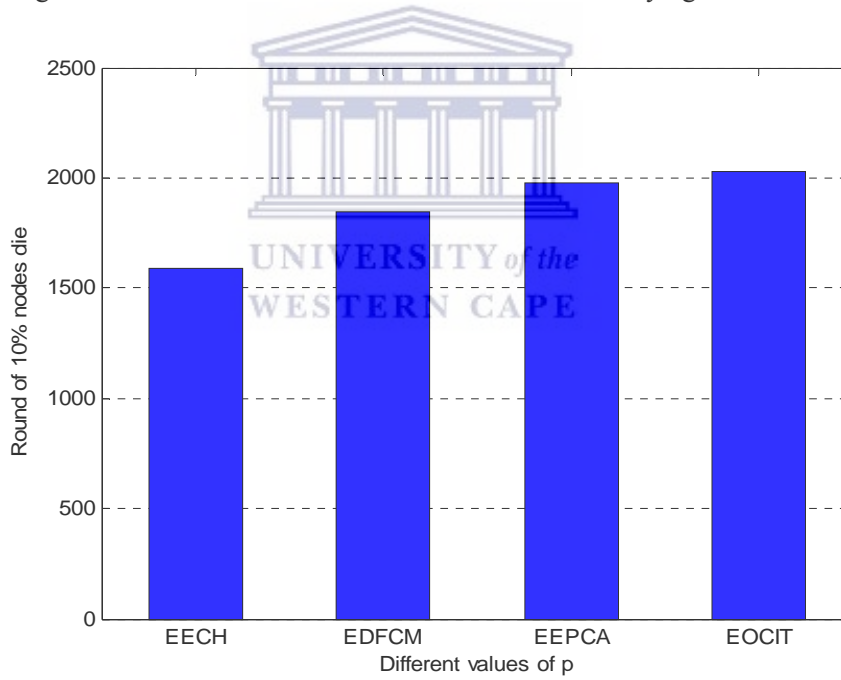

Figure 6.38: Network stable period



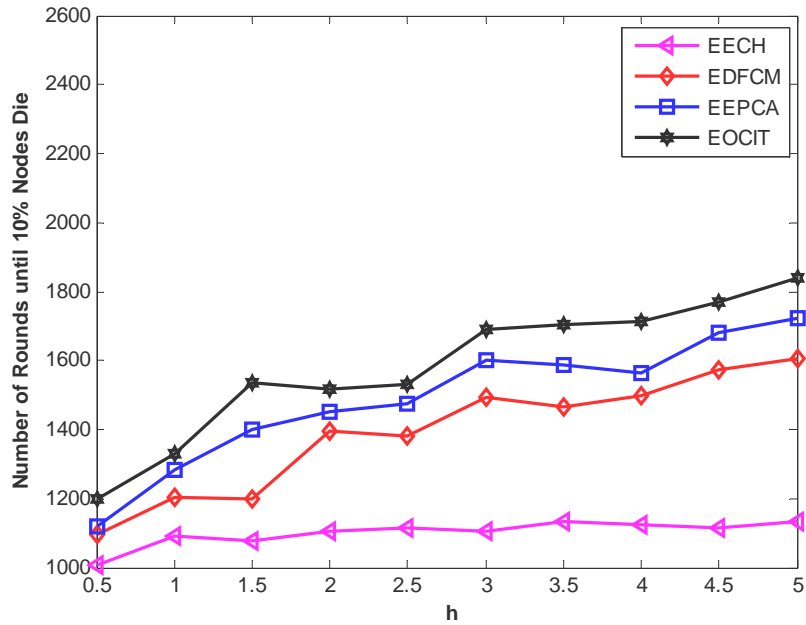

Figure 6.39: Number of rounds until 10% nodes die varying the value of h

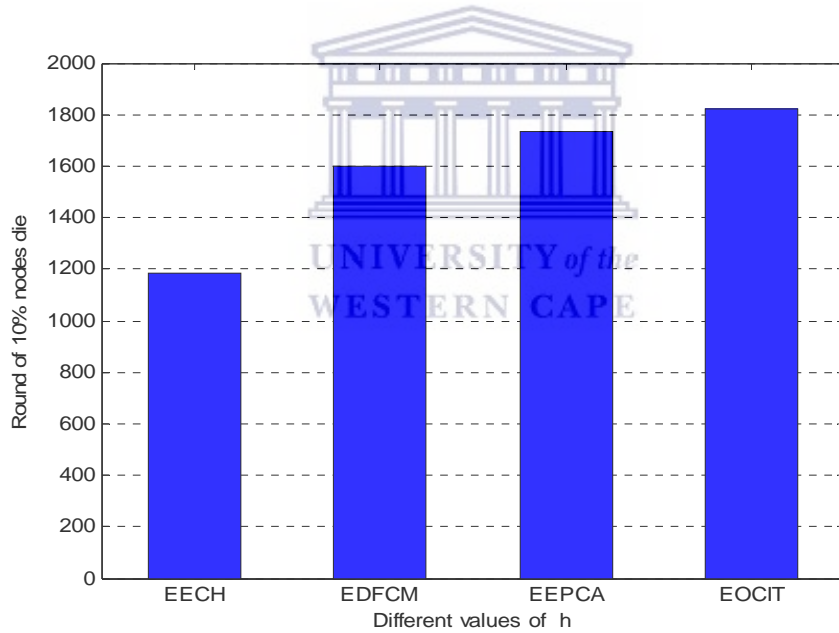

Figure 6.40: Network stable period

### 6.10 Performance evaluation of the load-balancing energy model

The performance of the load-balancing energy model proposed in section 3.4 is evaluated here. The average value of the results obtained during simulation are determined and used for plotting the graphs in the figures below.

The effect of network density on transmission radius  $r_1$  is examined here. The optimal value of  $r_1$  is denoted by the dotted line. It is observed that as the number of sensor nodes  $V$  increases from 100 to 500, at the optimal value, the network has maximum lifetime as shown in Figure 6.41. In addition, the optimal value  $r_1$  obtained through derivation is confirmed by the simulation results.

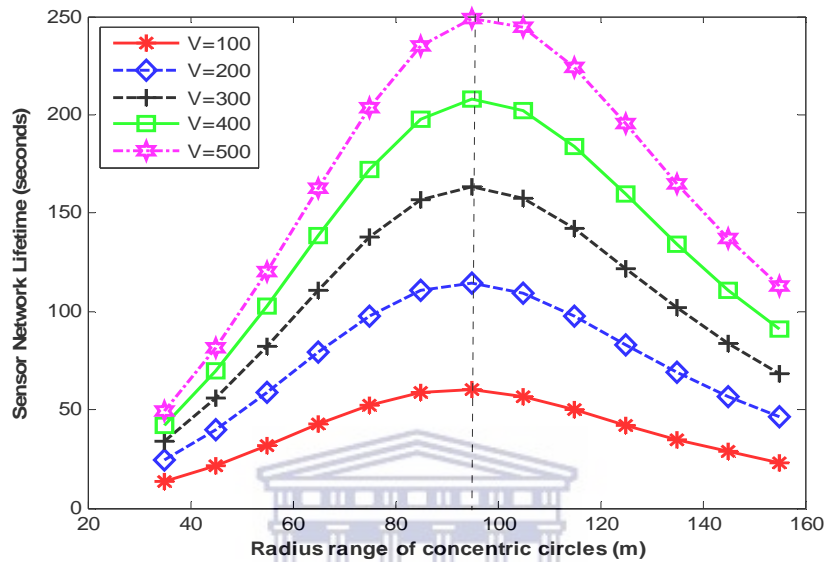

Figure 6.41: The effect of sensor nodes  $V$  on the optimal value of radius  $r_1$

Moreover, we varied the radius  $R$  of circular area of the network from 200 to 500 using the same transmission radius range  $r_1$  for a fixed number of randomly distributed 200 sensor nodes. We noticed that as the network radius increases, the lifetime of the network decreases as shown in Figure 6.42. The reason is that as  $R$  increases, the distance between the nodes also increases and the nodes transmit through long distance, creating energy holes.

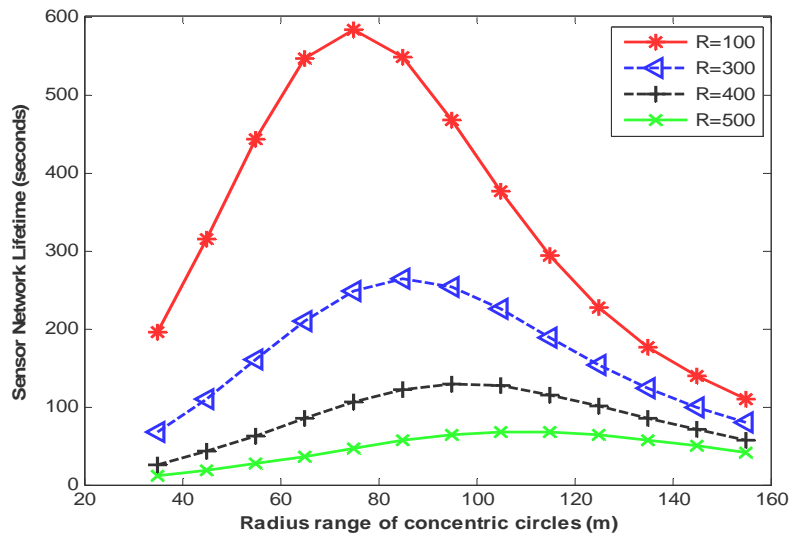

Figure 6.42: The effect of network radius  $R$  on the optimal value of radius  $r_1$

The effect of different transmission radius  $r_1$  on the optimal values of cluster  $K$  is also investigated in the simulation using 200 sensor nodes and varying the number of the clusters from 5 to 25 at interval of 5. Maximum sensor network lifetime is obtained when clusters are 5 and distance is 60m from the base station while the network lifetime is least when the clusters are 25 as shown in Figure 6.43.

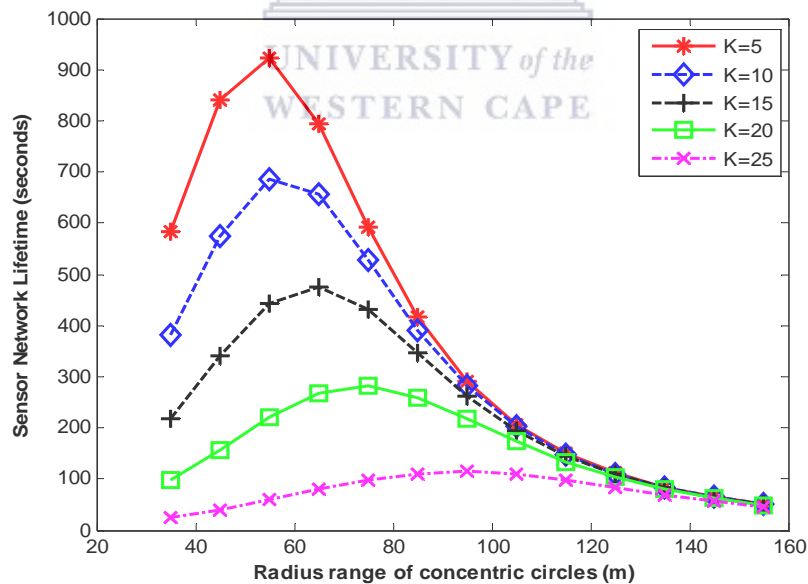

Figure 6.43: The Effect of cluster heads  $K$  on the optimal value of radius  $r_1$

## 6.11 Performance Analysis of Ant Colony Optimization Algorithm

The simulation results obtained for the three algorithms described in chapter 5 are presented here. They are: RAACO (Ahmed et al., 2012), RGM (J. Lee et al., 2012), and EAMR (Agarwal, 2013) algorithms. The simulation set-up was the same with the setting for EOCIT and the metrics discussed in section 6.1 are used to evaluate the performance of the MRACO. These four protocols were evaluated over a network area 200m x 200m with sensor nodes deployed in a random fashion and which varied from 100 to 500 nodes. The simulation also runs 80 times to generate different network topologies in order to guarantee the accuracy of results. The average values of the runs are determined and the values are used for the plotting of the figures below.

### 6.11.1 Distribution of dissipated energy of sensor nodes

Further study is conducted on energy dissipation for different sensor node density. The RGM protocol dissipated energy most during data transmission. The reason is that the protocol keeps multiple paths and does not consider the residual energy of the receiver's node which increases the number of packet drops in the network if the energy of the receiver node is very low. Moreover, energy dissipated by EAMR protocol is less than RGM protocol as shown in Figure 6.44 because it transmits through an alternate path in case there is congestion along the primary path. The proposed protocol MRACO dissipated the least energy because the following parameters are considered: the residual energy, distance between the sender's node and receiver's node, and the amount of data currently processed at the receiver's node. The algorithm ensures data packets are transmitted to the relay node through a less congested path, reducing the time that the data packet has to wait in a queue. Thus, MRACO outperforms RGM and EAMR protocols in terms of energy dissipation and energy consumption of sensor nodes is more evenly distributed than DECSA and MOCRN protocols.

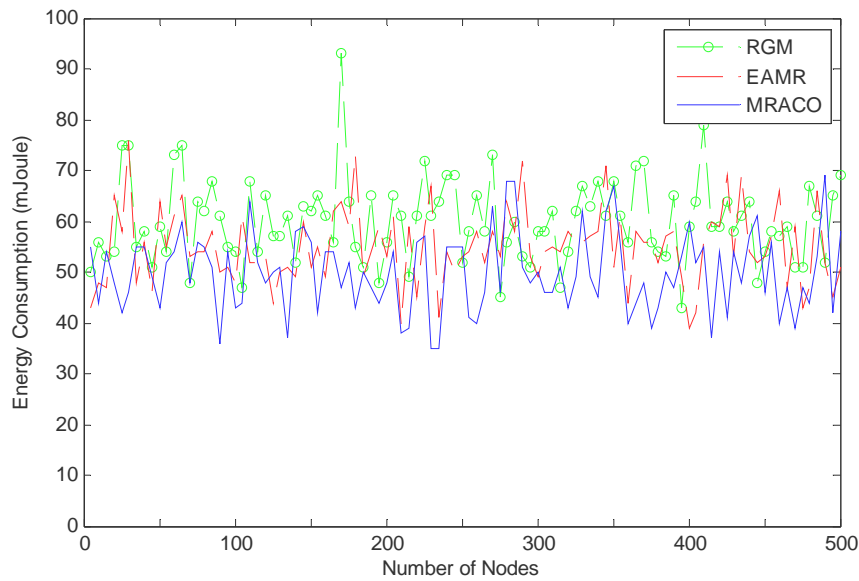

Figure 6.44: Distribution of dissipated energy vs number of nodes



#### *Average transmission delay*

Average transmission delay for the four algorithms was investigated using 200 sensor nodes randomly distributed over a network area of 200m x 200m. Figure 6.45 shows the time of sending data packets which varies with time in all the algorithms. MRACO has less than average transmission delay compared to EAMR, RGM, and RAACO protocols. The reason is that it transmits through a multi-path, and it chooses a node with sufficient energy and processes less data as the next hop node. This reduces the amount of waiting time that can result in to packets loss during transmission. It uses network information to update the tour pheromone value and minimizes average transmission delay. On the other hand, in RAACO and RGM an optimum tour is established in the network through flooding, leading to increase network delay. Thus, MRACO performs better compared to EAMR, RGM, and RAACO.

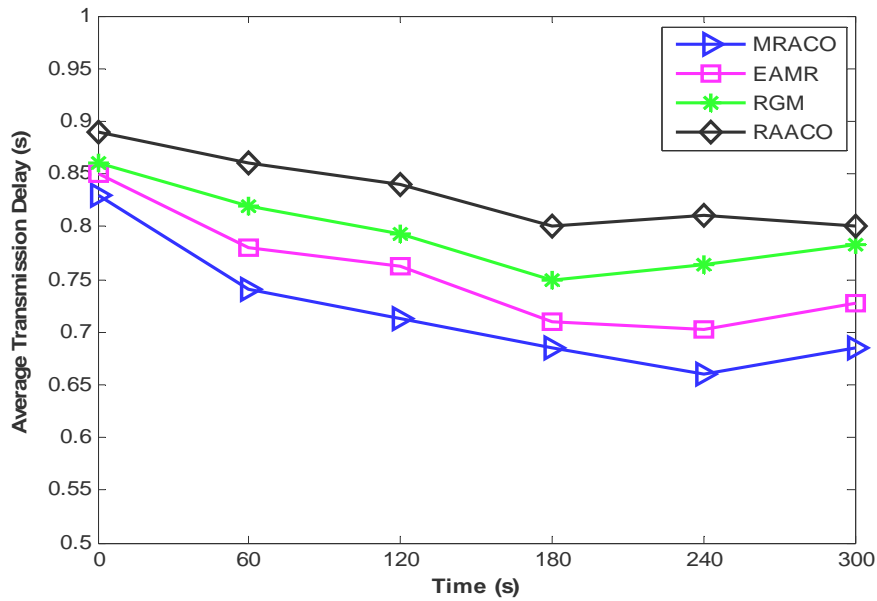

Figure 6.45: Average transmission delay vs time

### *Energy consumption*

An increase in energy consumption is observed as the network density increases for all the algorithms. This brings more data traffic into the sensor network and increases the energy consumption of the sensor nodes. EAMR and MRACO consume less energy compared to RGM and RAACO algorithms. The reason is that data loss in EAMR is minimal, as it uses an alternate path if the primary path fails. MRACO takes advantage of clustering to remove redundant data and also considered the residual energy of the receiver node before data transmission, thus reducing the amount of data loss during transmission and minimizing retransmission of data packets. However, RAACO consumed the highest energy among the four protocols, because it does not take advantage of clustering to remove similar sensed data from sensor nodes as shown in Figure 6.46. Thus, the proposed MRACO protocol consumes the least energy and outperforms other protocols.

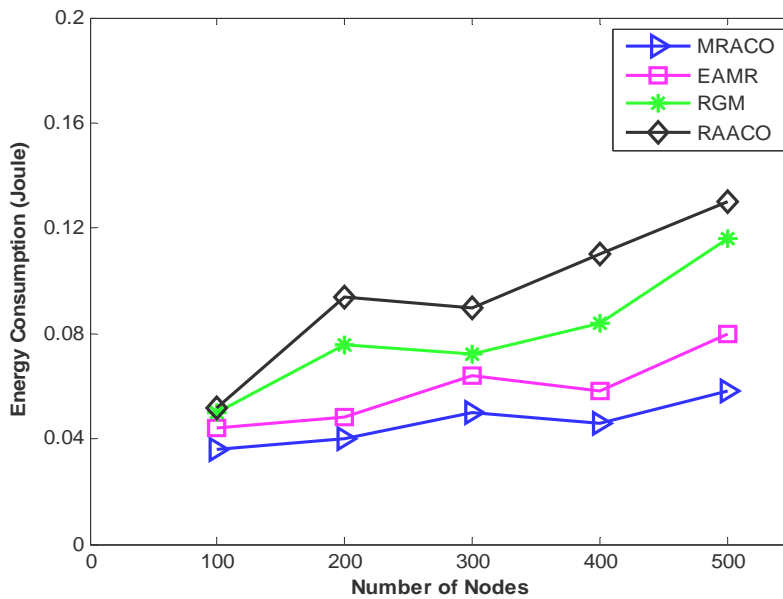

Figure 6.46: Energy consumption vs number of sensor nodes

### Network Lifetime

The sensor network lifetime for the four algorithms is shown in Figure 6.47. The network lifetime for the protocols dynamically changed as the nodes' density increased. MRACO has maximum network lifetime among the four protocols. The reason is that clusters formed based on our algorithms ensure selected cluster heads are well distributed within the network. This reduces communication distances between the cluster heads and the base station; data packets are also transmitted through optimal paths to the base station. However, RAACO algorithm outperforms RGM because it transmits through energy efficient paths to the base station. The performance of EAMR is the worst among the four algorithms because it always uses the primary path constructed for its data transmission, which results in energy of the sensor nodes in the primary route dissipating very fast. Finally, MRACO has the best performance among the four protocols and it has maximum network lifetime as shown in Figure 6.47.

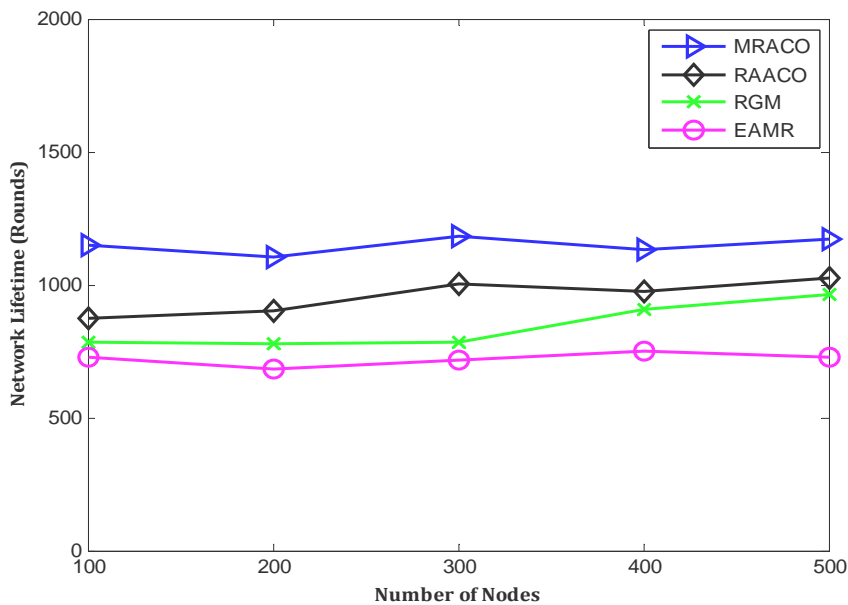

Figure 6.47: Network lifetime vs number of nodes

## 6.12 Chapter Summary

This chapter has presented the results obtained in attempting to meet the research objectives. It will be recalled that the objectives for this research stated at the beginning of the thesis focused on derivation of energy models, developing energy efficient algorithms and validation of the developed energy models and algorithms using MATLAB. It is therefore essential to examine whether the issues have been addressed using the methodologies adopted.

This chapter has addressed the problem of sensor nodes' energy consumption in wireless sensor networks using one of the data reduction approaches i.e clustering. This was aimed to minimize the energy consumption of sensor nodes and maximizing the lifetime of a wireless sensor network.

Moreover, the linear programming model developed is used to determine the average network lifetime of sensor nodes in a network and different results were obtained. Hypothesis is formulated to establish the relationship in terms of energy consumption between the direct transmission and the clustering protocols. The results obtained show that



using clustering approach is more energy efficient compared to the direct transmission for a sensor network.

The proposed EOCIT protocol is compared with LDD, DECSA, and MOCRN protocols to measure the performance of our algorithms using some metrics include the end-to-end delay, the throughput, and the packets delivery ratio. Moreover, the MRACO algorithm is developed to find the energy efficient paths between the sender nodes and the base station. The graphs of the results obtained were presented.

In conclusion, this study shows that the network lifetime of a wireless sensor network can be significantly extended by using the proposed approaches.



## **Chapter 7**

### **7 Contributions and Future work**

In the previous chapter, the research results were presented and discussed. This chapter evaluates the contributions of this thesis to the body of knowledge in the area of energy optimization for wireless sensor networks (WSNs). Conclusions are drawn based on the summary of what have been done in the research as presented in the previous chapters. Recommendations are then made for the future research.

Wireless sensor network is one of the first ten emerging technologies for the twenty first century, has provided a good way to bridge the gap between the real and the digital world. One of the main challenges of WSNs in achieving efficient operation for a longer period is the limited power available to the sensor nodes. Energy efficiency is an important issue in WSNs since the sensor nodes are powered by small batteries. In order to extend the lifetime of the sensor nodes and the network, the data packets should be transmitted such that the energy consumption is evenly distributed among the nodes in proportion to their residual energy.

In this dissertation, we propose energy optimization for wireless sensor networks using hierarchical routing techniques. The proposed method partitions the network into clusters using a new method for cluster head selection. Our approach applies service differentiation and node association in forming the clusters, rotating the role of the cluster heads among the nodes. The main features that differentiate the proposed approach from the previous methods include the method used for the cluster heads selection, formation of clusters, and the service delivery. Simulation results show that the proposed approach is an effective and efficient method to address the limited energy problem in wireless sensor networks.

## **7.1 Summary of contributions**

This dissertation describes and provides different methods to minimize energy consumption of sensor nodes in wireless sensor networks (WSNs). As evident from many citations cited in this dissertation, the main challenge of WSNs has been individually addressed in various researches but no study has ever addressed the energy problem inherent in WSNs as provided in this dissertation.

The main contribution of this dissertation include 1) propose corrective measures to the traditional energy model adopted in the current sensor networks simulations that erroneously discount both the role played by each node and the sensor node capability and

fabric and 2) apply these measures to a novel hierarchical routing architecture aiming at maximizing sensor networks lifetime.

The proposed service aware energy model is presented in section 3.3. Every sensor node plays a different role in the network. The network is modeled based on different services provided by the sensor nodes based on the assumption that every sensor node generates and transmits different data packet sizes at different times. This model is different from the traditional energy model proposed in an application - specific protocol architecture for wireless micro-sensor networks (Heinzelman et al., 2002) in which the model assumed that all sensor nodes transmit the same  $q$  bits of data packets.

The second is service aware energy model for sensor nodes with different capabilities. In this model, an individual node transmits sensed data to its cluster head through minimum communication distance.

The third model developed is the loading balancing energy model to mitigate the formation of energy holes in wireless sensor networks.

In addition, we presented two novel approaches for clustering the nodes of a hierarchical sensor network: a) a service-aware clustering where the nodes of a sensor network are clustered according to their service offered to the network and their residual energy and 2) a distance-aware clustering where nodes are clustering based on their distances and the residual energy. The proposed protocol is built around three schemes: energy aware cluster based, topology based, and service differentiation schemes.

The EOCIT protocol is designed with the following features to achieve the objectives of this research.

*Simplicity of deployment:* EOCIT is self-configuring; this ensures that the sensor nodes can be simply deployed in smart parking system, hostile, remote or inaccessible areas. The proposed protocol is based on a distributed algorithm whereby sensor nodes make independent decisions that result in all nodes being allocated into clusters. Moreover, the method used for the node association in EOCIT is based on the received signal strength (RSS) to determine the communication distance between the nodes, rather than depending on hop count or distance information. This ensures that sensor nodes locations do not require to be known a priori.

*Maximum network lifetime:* This thesis formulates the routing problem in WSNs as a linear programming to address the problem of maximizing the sensor network's lifetime.

The formulation extends the linear programming formulated in (Zhao and Yang 2012). We included two more constraints into the linear programming formulation: lower and upper bounds constraints and the residual energy constraint. The aim is to transmit data packets in energy efficient way such that the sensor network lifetime is maximized.

This thesis presents a formula analytically derived to calculate an optimal number of clusters for a given wireless sensor network. The formula assists network designers to gain an idea of the optimal number of clusters in a network for energy efficiency. The value of optimal clusters obtained through the analytical derivation correlates to the simulation results obtained in our implementation.

Another unique contribution of this work is that we are able to establish statistically that there is a significant difference in energy consumption between the direct transmission and the clustering protocols using a 2-tailed independent samples test at 95% Confidence Interval.

This research extends the sensor network to include the hybrid nodes in order to prolong the network sustainability. Three different models were implemented to determine the number of nodes alive in a network. The models contain both the hybrid nodes and the normal nodes in the ratio 1:4. The difference between the models is the time (number of rounds) that the service differentiation of the hybrid nodes is considered. In these models, various interesting results were obtained for the three models and the results are presented in chapter 6.

We develop a platform to compare our proposed protocol with other protocols– DECSA and MOCRN using performance metrics such as the average network lifetime, energy consumption, throughput, packet delivery ratio, and packet loss. The results show that the proposed EOCIT protocol outperforms these two selected protocols.

This research proposes an improved ant colony optimization (ACO) algorithm called MRACO (Multipath Routing protocol based on Ant Colony Optimization) for WSNs to find energy efficient routing paths for sensor readings dissemination from the cluster heads to the sink/base station of a hierarchical sensor network.

MRACO added three new parameters to the existing ACO transition probability formula: the residual energy of the receiver node, distance between the two communicating nodes, and the amount of data currently processed by the receiver node. MRACO is compared with RAACO, RGM, and EAMR protocols, the performance evaluation shows that MRACO minimizes sensor nodes energy consumption, achieves load balancing, and maximizes network utilization.

Table 7.1: Summary of Research Contributions

| Category  | Typical Activity   | Remarks   |
|---|--|---|
| Problem identification                          | Identified the main challenges of wireless sensor networks (i.e limited power availability, scalability, failures of nodes)                | Achieved through review of journal papers, conference papers, and reading related textbooks |
| Theoretical analysis                            | Provided different equations, derivation of mathematical formulas, design of different energy models, assumptions to aid simulation        | Achieved  |
| Design  | Designed architectural framework, flowcharts and algorithms  | Simulated and evaluated   |
| Comparison of the existing methodologies        | Compared various theoretical models, system designs, algorithmic methodologies or implementation in a unique way                           | Achieved  |
| Implementation                                  | Implemented the research objectives using MATLAB   | Achieved  |
| Empirical analysis of the models and algorithms | Studied the performance of the implementation in a unique way by observing and comparing the results obtained with the research objectives | Efficient and effective   |
| Application of the research                     | It has significance and numerous industrial, healthcare, environmental, and academic applications  | Car parking monitoring system, medical monitoring applications                              |

## 7.2 Recommendations and Future work

It is evident from the dissertation that the main challenge of wireless sensor networks has been addressed and cannot be overlooked either by network designers or the users. However, since the designed models and algorithms were implemented through simulation;

it is therefore necessary to do the real implementation in a real test-bed for proof of the concept.

In future work, we will compare the location of our base station with multiple mobile base stations to assess the impact of the number of base stations on the sensor network lifetime.

Node localization is another challenge for sensor networks, although quite a number of algorithms have been proposed. In order to make sensor networks more efficient and reliable coupled with quality of service (QoS), the following points should be taken into consideration in relation to node localization.

- Every individual sensor node should have identification (ID) for node identification.
- Sensor nodes should have more capability for additional resources.

In the future, we intend to extend this research to include the concept of security in wireless sensor networks. With the recent increase in WSNs applications, it is necessary to protect information flowing through the sensor networks from malicious attacks by improving security measures in the network bearing in mind the resource constraints in sensor nodes.

Finally, in a future work, we anticipate the implementation of the proposed MRACO algorithm on a suitable mote, study a dual method in the choice of the base station, self-elimination of the backward ants (BAs) in case there is a communication link failure and other means of retrieving the information carried by the BAs to prevent loss of information. Further studies may be required on some protocols based on jitter, latency, quality of service and delay; this will further improve the efficiency of the network performance.

## References

Abbasi, A. A., and Younis, M. (2007). A survey on clustering algorithms for wireless sensor networks. *Computer Communications*, 30(14), 2826-2841.

- Abidoye, A. P., Azeez, N. A., Adesina, A. O., and Agbele, K. K. (2011). ANCAEE: A novel clustering algorithm for energy efficiency in wireless sensor networks. *Journal of Wireless Sensor Networks*, 3(9), 307-312.
- Agarkhed, J., Biradar, G., and Mytri, V. (2012). Energy Efficient QoS Routing in Multi-Sink Wireless Multimedia Sensor Networks. *International Journal of Computer Science and Network Security*, 12(5), 25-31.
- Agarwal, P. (2013). *Energy Aware Multipath Routing in Wireless Sensor Networks*. (MSc Thesis), National Institute of Technology Rourkela, India.
- Ahmed, M., Boudhir, A., and Bouhorma, M. (2012). New Routing Algorithm Based on ACO Approach for Lifetime Optimization in Wireless Sensor Networks. *Int'l Journal of Networks and System*, 1(2), 64-67.
- Akbari, A., Hoshyar, R., and Tafazolli, R. (2010). Energy-efficient resource allocation in wireless OFDMA systems. *Proc. 2010 IEEE Personal, Indoor and Mobile Radio Commun. Sympos*, 1731-1735.
- Akyildiz, I. F., and Vuran, M. C. (2010). *Wireless Sensor Networks* (first edition ed.). New York: John Wiley & Sons.
- Ali, H., Shahzad, W., and Khan, F. A. (2012). Energy-efficient clustering in mobile ad-hoc networks using multi-objective particle swarm optimization. *Applied Soft Computing*, 12(7), 1913-1928.
- Amri, H. A., Abolhasan, M., and Wysocki, T. (2010). Scalability of MANET routing protocols for heterogeneous and homogenous networks. *Computers & Electrical Engineering*, 36(4), 752-765.
- Anastasi, G., Conti, M., Di Francesco, M., and Passarella, A. (2009). Energy conservation in wireless sensor networks: A survey. *Ad Hoc Networks*, 7(3), 537-568.
- Ba, H., Parvin, J., Soto, L., Demirkol, I., and Heinzelman, W. (2013). Passive RFID-based wake-up radios for wireless sensor networks. *Wirelessly Powered Sensor Networks and Computational RFID*, 113-129.
- Bagula, A. B. (2010). Modelling and implementation of QoS in wireless sensor networks: a multiconstrained traffic engineering model. *EURASIP Journal on Wireless Communications and Networking*, 2010, 1.
- Bai, Q. (2010). Analysis of Particle Swarm Optimization Algorithm. *Computer and Information Science*, 3(1), 180-184.
- Baqer, M., and Kamal, A. (2009, Dec.). *S-sensors: Integrating physical world inputs with social networks using wireless sensor networks*. Proceedings of Intelligent Sensors, Sensor Networks and Information Processing (ISSNIP '09), , Melbourne, Victoria, Australia.
- Baronti, P., Pillai, P., Chook, V., Chessa, S., Gotta, A., and Hu, F. (2007). Wireless sensor networks: A survey on the state of the art and the 802.15. 4 and ZigBee standards. *Computer Communications*, 30 (7), 1655-1695.
- Bemana, A. (2012). Performance Improvement of Direct Diffusion Algorithm in Sensor Networks. *Middle-East Journal of Scientific Research*, 12(11), 1566-1574.
- Bertrand, A., and Moonen, M. (2012). Distributed node-specific LCMV beamforming in wireless sensor networks. *Signal Processing, IEEE Transactions on*, 60(1), 233-246.
- Blum, C., and Li, X. (2008). *Swarm Intelligence in Optimization*. Proceedings of Natural Computing Series, Springer, Berlin, Germany.

- Borms, J., Steenhaut, K., and Lemmens, B. (2010). Low-overhead dynamic multi-channel mac for wireless sensor networks *Wireless Sensor Networks* (pp. 81-96): Springer.
- Buratti, C., Conti, A., Dardari, D., and Verdone, R. (2009). An overview on wireless sensor networks technology and evolution. *Sensors*, 9(9), 6869-6896.
- Casilari, E., Cano-García, J. M., and Campos-Garrido, G. (2010). Modeling of current consumption in 802.15. 4/ZigBee sensor motes. *Sensors*, 10(6), 5443-5468.
- Catarinucci, L., Guglielmi, S., Patrono, L., and Tarricone, L. (2013). Switched-Beam Antenna for Wireless Sensor Network Nodes. *Progress In Electromagnetics Research C*, 39, 193-207.
- Chadha, A. K. G. (2013). Review on Enhanced Interior Gateway Routing Protocol. *Global Journal of Computer Science and Technology*, 13(6), 40-44.
- Chen, R.-M. (2011). Application of Discrete Particle Swarm Optimization for Grid Task Scheduling Problem. In Z. Constantinescu (Ed.), *Advances in Grid Computing* (pp. 3-18). Janeza Trdine 9, 51000 Rijeka, Croatia: InTech.
- Chen, Y., Yang, F., and Sun, J. (2006). A new Particle swarm optimization Algorithm. *Journal of Jilin University*, 24(2), 181-183.
- Chiang, M. H. (2008). *Energy Optimization in Wireless Sensor Networks: A Study of Power Consumption and Energy Optimization*: VDM Publishing.
- Chinnappen-Rimer, S., and Hancke, G. (2012). Calculation of an Optimum Mobile Sink Path in a Wireless Sensor Network *Wireless Sensor Networks, technology and Protocols* (pp. 49-70): INTECH.
- Choe, H. J., Ghosh, P., and Das, S. K. (2009). *Cross-layer design for adaptive data reporting in wireless sensor networks*. Proceedings of IEEE International Conference on Pervasive Computing and Communications, Galveston, Texas.
- Choe, J., and Kim, K. (2008, Dec.). *EADD: Energy aware directed diffusion for wireless sensor networks*. Proceedings of International Symposium on Parallel and Distributed Processing with Applications, 2008. ISPA'08, Sydney, New South Wales, Australia.
- Ciullo, D., Celik, G. D., and Modiano, E. (2010, May). *Minimizing transmission energy in sensor networks via trajectory control*. Proceedings of 8th Int'l Symposium on Modeling and Optimization in Mobile, Ad Hoc and Wireless Networks (WiOpt)
- CPLEX, I. I. (2011). 12.0 Optimization Studio: IBM.
- Dargie, W., and Poellabauer, C. (2010). *Fundamentals of wireless sensor networks: theory and practice*: John Wiley & Sons.
- Dargie, W., and Poellabauer, C. (2010). *Fundamentals of wireless sensor networks: theory and practice*, John Wiley and Sons. ISBN 978-0-470-99765-9.
- Das, S. K., and Ammari, H. M. (2009). ROUTING AND DATA DISSEMINATION *Wireless Sensor Networks: A Networking Perspective* (pp. 67-143).
- Dietrich, D., Bruckner, D., Zucker, G., and Palensky, P. (2010). Communication and computation in buildings: A short introduction and overview. *Industrial Electronics, IEEE Transactions on*, 57(11), 3577-3584.
- Dorigo, M. (1992). *Ottimizzazione, apprendimento automatico, ed algoritmi basati su metafora naturale*. Unpublished doctoral dissertation, PhD thesis, Dipartimento di Elettronica, Politecnico di Milano.
- Dorigo, M. (2010, Sept.). *Swarm Intelligence*. Proceedings of 7th International Conference, ANTS Brussels, Belgium.



- Dorigo, M., and Birattari, M. (2010). Ant colony optimization *Encyclopedia of Machine Learning* (pp. 36-39): Springer.
- Dorigo, M., Birattari, M., Blum, C., Clerc, M., Stützle, T., Winfield, A. (2008, Sept.). *Ant Colony Optimization and Swarm Intelligence (ANTS '08)*. . Proceedings, Brussels, Belgium.
- Dorigo, M., and Gambardella, L. (1997). Ant colony system: A cooperative learning approach to the traveling salesman problem. *IEEE Transactions on Evolutionary Computation*, 1(1), 53-66.
- Du, W., Navarro, D., Mieleville, F., and Gaffiot, F. (2010, May). *Towards a taxonomy of simulation tools for wireless sensor networks*. Proceedings of 3rd International ICST Conference on Simulation Tools and Techniques, Brussels, Belgium.
- Dulman, S., Wu, J., and Havinga, P. (2003). An energy efficient multipath routing algorithm for wireless sensor networks.
- Eberhart, R., and Kennedy, J. (1995, Oct. ). *A new optimizer using particle swarm theory*. Proceedings of IEEE Sixth International Symposium on Micro Machine and Human Science, Nagoya, Japan.
- Eberhart, R., and Shi, Y. (2007). *Computational Intelligence Concept to Implementation*. Oxford, UK: Morgan Kaufmann Publishers is an imprint of Elsevier,30 Corporate Drive, Suite 400, Burlington, MA 01803.
- Ehsan, S., and Hamdaoui, B. (2012). A survey on energy-efficient routing techniques with QoS assurances for wireless multimedia sensor networks. *IEEE Communications Surveys and Tutorials*, 14(2), 265-278.
- Elshakankiri, N., Moustafa, N., and Dakrou, Y. (2008). Energy Efficient Routing Protocol for Wireless Sensor Network. *IEEE International Conference*, 393-398.
- Engelbrecht, A. (2007). *Introduction to computational Intelligence* (Vol. 2). England: John Wiley & Sons Ltd, The Atrium, Southern Gate, Chichester West Sussex PO19 8SQ.
- Estrin, D., Culler, D., Pister, K., and Sukhatme, G. (2002). Connecting the physical world with pervasive networks. *IEEE Pervasive Computing*, 59-69.
- Fathima, K. S. A., and Sindhanaiselvan, M. K. (2013). Ant Colony Optimization Based Routing in Wireless Sensor Networks. *Int. J. Advanced Networking and Applications*, 4(04), 1686-1689.
- Felemban, E., Vural, S., Murawski, R., Ekici, E., Lee, K., Moon, Y., and Park, S. (2010). SAMAC: a cross-layer communication protocol for sensor networks with sectored antennas. *Mobile Computing, IEEE Transactions on*, 9(8), 1072-1088.
- Gajjar, S. (2009, 28-29 December). *Factors Influencing the Wireless sensor Networks Design*. Proceedings of of the 2009 Int'l Conference on Signals Systems and Automation Florida, USA.
- Gambardella, L. M., and Dorigo, M. (1997). HAS-SOP: Hybrid And System for the Sequential Ordering Problem: Technical report IDSIA 11-97.
- Ganesan, D., Govindan, R., Shenker, S., and Estrin, D. (2001). Highly-resilient, energy-efficient multipath routing in wireless sensor networks. *ACM SIGMOBILE Mobile Computing and Communications Review*, 5(4), 11-25.
- García Villalba, L. J., Sandoval Orozco, A. L., Triviño Cabrera, A., and Barenco Abbas, C. J. (2009). Routing protocols in wireless sensor networks. *Sensors*, 9(11), 8399-8421.
- Gendreau, M. (2010). *Handbook of Metaheuristics* (Vol. 146). New York: Springer.

- Ghosh, S., and Chakraborty, A. (2006). Performance analysis of EMI sensor in different test sites with different wave impedances. *Progress In Electromagnetics Research*, 62, 127-142.
- Goyal, D., and Tripathy, M. R. (2012, 7-8 Jan.). *Routing protocols in wireless sensor networks: A survey*. Proceedings of IEEE Second International Conference on Advanced Computing & Communication Technologies (ACCT), 2012 Rohtak, Haryana.
- Gu, Y., Wu, Q., and Rao, N. S. (2010). Optimizing cluster heads for energy efficiency in large-scale heterogeneous wireless sensor networks. *International Journal of Distributed Sensor Networks*, doi:10.1155/2010/961591. doi:doi:10.1155/2010/961591
- Gungor, V. C., Lu, B., and Hancke, G. P. (2010a). Opportunities and Challenges of Wireless Sensor Networks in Smart Grid. *IEEE Transactions on Industrial Electronics*, 57(10), 3557-3564.
- Gungor, V. C., Lu, B., and Hancke, G. P. (2010b). Opportunities and challenges of wireless sensor networks in smart grid. *Industrial Electronics, IEEE Transactions on*, 57(10), 3557-3564.
- Gupta, S. K., Jain, N., and Sinha, P. (2013). Clustering Protocols in Wireless Sensor Networks: A Survey. *challenge*, 5(2), 41-50.
- Han, K., Xiang, L., Luo, J., and Liu, Y. (2012, June). *Minimum-energy connected coverage in wireless sensor networks with omni-directional and directional features*. Proceedings of thirteenth ACM int'l symposium on Mobile Ad Hoc Networking and Computing.
- Haque, E., and Yoshida, N. (2012). Clustering in Wireless Sensor Networks: Context-Aware Approaches. *Internet and Distributed Computing Advancements: Theoretical Frameworks and Practical Applications*, 197-211.
- Harb, A. (2011). Energy harvesting: State-of-the-art. *Renewable Energy*, 36(10), 2641-2654.
- He, S., Chen, J., Yau, D. K., and Sun, Y. (2010, June). *Cross-layer optimization of correlated data gathering in wireless sensor networks*. Proceedings of 7th Annual IEEE Communications Society Conference on Sensor Mesh and Ad Hoc Communications and Networks (SECON), Boston, Massachusetts, USA.
- Heidemann, J., Stojanovic, M., and Zorzi, M. (2012). Underwater sensor networks: applications, advances and challenges. *Philosophical Transactions of the Royal Society A: Mathematical, Physical and Engineering Sciences*, 370(1958), 158-175.
- Heikalabad, S. R., Navin, A. H., Mirnia, M., Ebadi, S., and Golesorkhtabar, M. (2010). EBDHR: Energy Balancing and Dynamic Hierarchical Routing algorithm for wireless sensor networks. *IEICE Electronics Express*, 7(15), 1112-1118.
- Heinzelman, Chandrakasan, A., and Balakrishnan, H. (2002). An application - specific protocol architecture for wireless microsensor networks. *IEEE Transactions on Wireless Communications*, 1(4), 660-670.
- Hiot, L. M. (2010). *Adaptation, Learning, and Optimization: Handbook of Swarm Intelligence: Concepts, Principles and Applications* (Vol. 8): Springer.
- Huang, J.-T., Shiao, J.-H., and Wu, J.-M. (2010). A miniaturized Hilbert inverted-F antenna for wireless sensor network applications. *Antennas and Propagation, IEEE Transactions on*, 58(9), 3100-3103.

- Iannello, F., Simeone, O., and Spagnolini, U. (2012). Medium access control protocols for wireless sensor networks with energy harvesting. *Communications, IEEE Transactions on*, 60(5), 1381-1389.
- Incel, O. D., van Hoesel, L., Jansen, P., and Havinga, P. (2011). MC-LMAC: A multi-channel MAC protocol for wireless sensor networks. *Ad Hoc Networks*, 9(1), 73-94.
- Intanagonwiwat, C., Govindan, R., and Estrin, D. (2000a, August). *Directed Diffusion: A Scalable and Robust Communication Paradigm for Sensor Networks*. Proceedings of 6th Annual ACM/IEEE International Conference on Mobile Computing and Networking, Hawaii, US.
- Intanagonwiwat, C., Govindan, R., and Estrin, D. (2000b). Directed diffusion: A scalable and robust communication paradigm for sensor networks *Proceedings of ACM MobiCom 2000*, 56-67.
- Intanagonwiwat, C., Govindan, R., Estrin, D., Heidemann, J., and Silva, F. (2003). Directed diffusion for wireless sensor networking. *Networking, IEEE/ACM Transactions on*, 11(1), 2-16.
- Issariyakul, T., and Hossain, E. (2011). *Introduction to network simulator NS2*: Springer.
- Iyengar, S. S., and Brooks, R. R. (2012). *Distributed Sensor Networks: Sensor Networking and Applications* (Vol. 26): CRC Press.
- Jagadeesan, S., and Parthasarathy, V. (2012). Cross-Layer Design in Wireless Sensor Networks. *Advances in Computer Science, Engineering & Applications*, 283-295.
- Jing, H., and Aida, H. (2010). Cooperative Clustering Algorithms for Wireless Sensor Networks. *cite from Smart Wireless Sensor Networks InTech*, 157-172.
- Jones, V. M., Huis in't Veld, R., Tonis, T., Bults, R. B., Beijnum, B., Widya, I., . . . Hermens, H. (2008, October). *Biosignal and Context Monitoring: Distributed Multimedia Applications of Body Area Networks in Healthcare*. Proceedings of IEEE 10th Workshop on Multimedia Signal Processing, Cairns.
- Joo, C., Choi, J.-G., and Shroff, N. B. (2010, March). *Delay performance of scheduling with data aggregation in wireless sensor networks*. Proceedings of IEEE INFOCOM, San Diego, California, USA.
- Jurdak, R., Ruzzelli, A. G., and O'Hare, G. M. (2010). Radio sleep mode optimization in wireless sensor networks. *Mobile Computing, IEEE Transactions on*, 9(7), 955-968.
- Karl, H., and Willig, A. (2007). *Protocols and architectures for wireless sensor networks*: John Wiley & Sons.
- Kulkarni, R., Forster, A., and Venayagamoorthy, G. (2011). Computational Intelligence in Wireless Sensor Networks: A Survey. *IEEE Communications Surveys & Tutorials, First Quarter (2011)*, 13(1), 68-96.
- Kulkarni, R. V., Forster, A., and Venayagamoorthy, G. K. (2011). Computational intelligence in wireless sensor networks: A survey. *Communications Surveys & Tutorials, IEEE*, 13(1), 68-96.
- Kulkarni, R. V., and Venayagamoorthy, G. K. (2011). Particle swarm optimization in wireless-sensor networks: A brief survey. *Systems, Man, and Cybernetics, Part C: Applications and Reviews, IEEE Transactions on*, 41(2), 262-267.
- Kumar, A., Chand, N., and Kumar, V. (2011). Location Based Clustering in Wireless Sensor Networks. *World Academy of Science, Engineering and Technology*, 1315-1318.

- Kumar, D., Aseri, T. C., and Patel, R. (2009). EEHC: Energy efficient heterogeneous clustered scheme for wireless sensor networks. *Computer Communications*, 32(4), 662-667.
- Kumar, D., Aseri, T. C., and Patel, R. (2011). EECDA: energy efficient clustering and data aggregation protocol for heterogeneous wireless sensor networks. *International Journal of Computers, Communications and Control*, 11, 113-124.
- Kumar, P., and Raghavendra, G. (2011). A Note on the Parameter of Evaporation in the Ant Colony Optimization Algorithm. *International Mathematical Forum*, 6(34), 1655-1659.
- Kuo, M., Wang, S., Hsu, C., and Chou, C. (2012). Joint Design of Asynchronous Sleep-wake Scheduling and Opportunistic Routing in Wireless Sensor Networks. 26(99), 247-254.
- Labrador, M. A., and Wightman, P. M. (2009). *Topology control in wireless sensor networks* (Vol. 412): Springer Science and Business Media
- Lai, W. K., Lin, Y.-C., Chen, T.-H., and Shieh, C.-S. (2011, Aug.). *Load-Balance Directed Diffusion in Wireless Sensor Networks*. Proceedings of 5th Int'l Conf. on Genetic and Evolutionary Computing (ICGEC), Xiamen, China.
- Law, Y. W., Palaniswami, M., Hoesel, L. V., Doumen, J., Hartel, P., and Havinga, P. (2009). Energy-efficient link-layer jamming attacks against wireless sensor network MAC protocols. *ACM Transactions on Sensor Networks (TOSN)*, 5(1), 6.
- Lazinica, A. (2009). *Particle swarm optimization*: InTech.
- Le-Huy, P., and Roy, S. (2010). Low-power wake-up radio for wireless sensor networks. *Mobile networks and applications*, 15(2), 226-236.
- Le Sueur, E., and Heiser, G. (2010, Oct.). *Dynamic Voltage and Frequency Scaling: The Laws of Diminishing Returns*. Proceedings of International conference on Power Aware Computing and Systems, Vancouver, Canada.
- Lee, J.-W., Choi, B.-S., and Lee, J.-J. (2011). Energy-efficient coverage of wireless sensor networks using ant colony optimization with three types of pheromones. *Industrial Informatics, IEEE Transactions on*, 7(3), 419-427.
- Lee, J., Park, H., Oh, S., Yim, Y., and Kim, S.-H. (2012, March). *A radio-disjoint geographic multipath routing in wireless sensor networks*. Proceedings of IEEE 26th Int'l Conf. on Advanced Information Networking and Applications (AINA), Fukuoka, Japan.
- Leonard, B. J., and Engelbrecht, A. P. (2012). Scalability study of particle swarm optimizers in dynamic environments *Swarm Intelligence* (pp. 121-132): Springer.
- Li, X., Nayak, A., and Stojmenovic, I. (2010). *Sink mobility in wireless sensor networks*: Wiley, 2010.
- Liu, H., Abraham, A., Snášel, V., and McLoone, S. (2012). Swarm scheduling approaches for work-flow applications with security constraints in distributed data-intensive computing environments. *Information Sciences*, 192, 228-243.
- Liu, S., Fan, K.-W., and Sinha, P. (2009). CMAC: an energy-efficient MAC layer protocol using convergent packet forwarding for wireless sensor networks. *ACM Transactions on Sensor Networks (TOSN)*, 5(4), 29.
- Liu, X. (2012). A survey on clustering routing protocols in wireless sensor networks. *Sensors*, 12(8), 11113-11153.

- Malik, B., Alaa, S., and Aladdin, A. (2007). Particle Swarm Optimisation Enhancement Approach for Improving Image Quality. *International Journal of Innovative Computing and Applications*, 1(2), 138-145.
- Mammu, A. S. K., Sharma, A., Hernandez-Jayo, U., and Sainz, N. (2013, March). *A Novel Cluster-Based Energy Efficient Routing in Wireless Sensor Networks*. Proceedings of IEEE 27th Int'l Conf. on Advanced Information Networking and Applications (AINA), Barcelona, Spain.
- Maraiya, K., Kant, K., and Gupta, N. (2011). Wireless sensor network: a review on data aggregation. *International Journal of Scientific & Engineering Research*, 2(4), 1-6.
- Mehta, A., Kerkez, B., Glaser, S. D., and Pister, K. S. (2012). TDMA-Based Dual-Mode Communication for Mobile Wireless Sensor Networks. *Sensors*, 12(12), 16194-16210.
- Melodia, T., and Akyildiz, I. F. (2010). Cross-layer QoS-aware communication for ultra wide band wireless multimedia sensor networks. *Selected Areas in Communications, IEEE Journal on*, 28(5), 653-663.
- Miao, G., Himayat, N., Li, Y. G., and Swami, A. (2009). Cross-layer optimization for energy-efficient wireless communications: a survey. *Wireless Communications and Mobile Computing*, 9(4), 529-542.
- Mitchell, H. (2012). Introduction *Data Fusion: Concepts and Ideas* (pp. 1-14): Springer.
- Mohanad, A.-O. (2010). ENAMS: Energy Optimization Algorithm for Mobile Wireless Sensor Networks using Evolutionary Computation and Swarm Intelligence. *Thesis*.
- Moler, C. (2004). The Origins of MATLAB. Retrieved 3rd April, 2014, from <http://www.mathworks.com/company/newsletters/articles/the-origins-of-matlab.html>
- Murthy, J. K., Kumar, S., and Srinivas, A. (2012). Energy efficient scheduling in cross layer optimized clustered wireless sensor networks. *Int'l Journal of Computer Science and Communication*, 3(1), 149-153.
- Nam, C.-S., Bae, S.-T., Chung, J.-W., and Shin, D.-R. (2013). Multihop-Based Optimal Cluster Heads Numbers Considering Relay Node in Transmission Range of Sensor Nodes in Wireless Sensor Networks. *International Journal of Distributed Sensor Networks*, 1-10.
- Nayak, A., and Stojmenovi, I. (2010). *Wireless sensor and actuator networks*: Wiley Online Library.
- Nefzi, B., and Song, Y.-Q. (2012). QoS for wireless sensor networks: Enabling service differentiation at the MAC sub-layer using CoSenS. *Ad Hoc Networks*, 10(4), 680-695.
- Newman, M. (2010). *Computer Networks: An Introduction*: Oxford University Press, Inc.
- Ngai, E. C. H., Zhou, Y., Lyu, M. R., and Liu, J. (2006, October). *Reliable Reporting of Delay-Sensitive Events in Wireless Sensor Actuator Networks*. Proceedings of 3rd IEEE International Conference on Mobile Ad Hoc and Sensor Systems (IEEE MASS 2006), Vancouver, Canada.
- Overman, E. (2011). A MATLAB Tutorial. *Department of Mathematics. The Ohio State University, Columbus*.
- Pantazis, N., and Vergados, D. (2007). A survey on power control issues in wireless sensor networks. *IEEE Communications Surveys & Tutorials*, 9(4), 86-107.

- Peng, J., Liu, T., Hongyou, and Guo, B. (2013). Energy-Efficient Prediction Clustering Algorithm for Multilevel Heterogeneous Wireless Sensor Networks. *International Journal of Distributed Sensor Networks*, 2013.
- Philipp, F., and Glesner, M. (2011, Sept.). *Mechanisms and architecture for the dynamic reconfiguration of an advanced wireless sensor node.*, Proceedings of International Conference on Field Programmable Logic and Applications (FPL '11), Chania, Greece.
- Pintea, C.-M., Pop, P. C., and Chira, C. (2013). The generalized traveling salesman problem solved with ant algorithms. *arXiv:1310.2350*
- Potdar, V., Sharif, A., and Chang, E. (2009, May). *Wireless sensor networks: A survey.* Proceedings of Advanced Information Networking and Applications Workshops, (WAINA'09), Bradford, United Kingdom.
- Prasad, V., and Son, S. H. (2007, June). *Classification of analysis techniques for wireless sensor networks.* Proceedings of Fourth Int'l Conf. on Networked Sensing Systems, Braunschweig, Germany.
- Rachedi, A., Lohier, S. p., Cherrier, S., and Salhi, I. (2012). Wireless network simulators relevance compared to a real testbed in outdoor and indoor environments. *International Journal of Autonomous and Adaptive Communications Systems*, 5(1), 88-101.
- Ren, F., Zhang, J., He, T., Lin, C., and Ren, S. K. (2011). EBRP: energy-balanced routing protocol for data gathering in wireless sensor networks. *Parallel and Distributed Systems, IEEE Transactions on*, 22(12), 2108-2125.
- Saluja, R. K. (2012). An Improved Approach for Working outside the MANET by Extending MANET Routing Protocol. *IJCSI International Journal of Computer Science Issues*, 9(1), 1694-0814.
- Sen, S., Choudhury, R. R., and Nelakuditi, S. (2012). CSMA/CN: carrier sense multiple access with collision notification. *IEEE/ACM Transactions on Networking (TON)*, 20(2), 544-556.
- Sendra, S., Lloret, J., García, M., and Toledo, J. F. (2011). Power Saving and Energy Optimization Techniques for Wireless Sensor Networks. *Journal of communications*, 6(6), 439-459.
- Singh, S. K., Singh, M., and Singh, D. (2010). Routing Protocols in Wireless Sensor Networks—A Survey. *International Journal of Computer science and engineering Survey (IJCSSES)*, 1(2), 63-83.
- Sobral, J. V., Rabelo, R. A., Araujo, H. S., and Baluz, R. A. (2013, July ). *Automated design of fuzzy rule base using ant colony optimization for improving the performance in Wireless Sensor Networks.* Proceedings of IEEE Int'l Conf. on Fuzzy Systems (FUZZ), Hyderabad, India.
- Sohraby, K., Minoli, D., and Znati, T. (2007). *WIRELESS SENSOR NETWORKS, Technology, Protocols, and Applications* New Jersey: John Wiley & Sons, Inc., Hoboken, .
- Sundani, H., Li, H., Devabhaktuni, V. K., Alam, M., and Bhattacharya, P. (2011). Wireless sensor network simulators a survey and comparisons. *International Journal of Computer Networks (IJCN)*, 2(5), 249-265.
- Syed, J., and Partha, R. (2008). *Energy Saving Methods in Wireless Sensor Networks.* (M.Sc).

- Tan, R., Xing, G., Liu, B., Wang, J., and Jia, X. (2012). Exploiting data fusion to improve the coverage of wireless sensor networks. *Networking, IEEE/ACM Transactions on*, 20(2), 450-462.
- Tang, L., Sun, Y., Gurewitz, O., and Johnson, D. B. (2011a, May). *EM-MAC: a dynamic multichannel energy-efficient MAC protocol for wireless sensor networks*,. Proceedings of Twelfth ACM International Symposium on Mobile Ad Hoc Networking and Computing, Paris, France.
- Tang, L., Sun, Y., Gurewitz, O., and Johnson, D. B. (2011b, April). *PW-MAC: An energy-efficient predictive-wakeup MAC protocol for wireless sensor networks*,. Proceedings of International Conference on Computer Communications (INFOCOM 2011), Shanghai, China.
- Tilak, S., Abu-Ghazaleh, N., and Heinzelman, W. (2002). A taxonomy of wireless micro-sensor network models *Mobile Computing and Communications Review*, 6(2), 28-36.
- Tripathi, M., Battula, R., Gaur, M., and Laxmi, V. (2013, Dec.). *Energy Efficient Clustered Routing for Wireless Sensor Network*. Proceedings of IEEE 9th Int'l Conf. on Mobile Ad-hoc and Sensor Networks (MSN), Dalian, China.
- Tümer, A. E., and Gündüz, M. (2010). Energy-efficient and fast data gathering protocols for indoor wireless sensor networks. *Sensors*, 10(9), 8054-8069.
- Valle, Y. D., Venayagamoorthy, G. K., bMohagheghi, S., Hernandez J. C, Harley, R. G (2008). Particle swarm optimization: Basic concepts, variants and applications in power systems. *IEEE Transactions on Evolutionary Computation*, 12(2), 171-195.
- Varga, A., and Hornig, R. (2008, March). *An overview of the OMNeT++ simulation environment*. Proceedings of 1st Int'l Conf. on Simulation tools and techniques for communications, networks and systems & workshops, Brussels, Belgium.
- Vuran, M. C., and Akyildiz, I. F. (2010). XLP: A cross-layer protocol for efficient communication in wireless sensor networks. *IEEE Transactions on Mobile Computing*, 9(11), 1578-1591.
- Wang, Q., Hempstead, M., and Yang, W. (2006, Sept.). *A realistic power consumption model for wireless sensor network devices*. Proceedings of 3rd Annual IEEE Communications Society on Sensor and Ad Hoc Communications and Networks, Reston Virginia, United States.
- Wang, Y., Yang, T., and Zhang, D. (2009). An energy efficient and balance hierarchical unequal clustering algorithm for large scale sensor network. *Inform. Technol. J*, 8(1), 28-38.
- Wang, Z., Yang, K., and Hunter, D. K. (2012, Sept.). *Modelling and analysis of multi-sink wireless sensor networks using queuing theory*,. Proceedings of Computer Science and Electronic Engineering Conference (CEEC), Colchester, Uniter Kingdom.
- Wong, K. Y. (2010). Applying ant system for solving unequal area facility layout problems. *European Journal of Operational Research*, 202(3), 730-746.
- Xiao, Y., Lu, D., and Yu, L. (2010). *Multi-hop Clustering Algorithm for Wireless Sensor Networks*. Proceedings of Measuring Technology and Mechatronics Automation (ICMTMA), 2010 International Conference on.
- Yaghmaee, M. H., and Adjeroh, D. A. (2009). Priority-based rate control for service differentiation and congestion control in wireless multimedia sensor networks. *Computer Networks*, 53(11), 1798-1811.

- Yahya, B., and Ben-Othman, J. (2009). Towards a classification of energy aware MAC protocols for wireless sensor networks. *Wireless Communications and Mobile Computing*, 9(12), 1572-1607.
- Yang, D., Misra, S., Fang, X., Xue, G., and Zhang, J. (2012). Two-tiered constrained relay node placement in wireless sensor networks: computational complexity and efficient approximations. *Mobile Computing, IEEE Transactions on*, 11(8), 1399-1411.
- Yang, Y., Zhong, C., Sun, Y., and Yang, J. (2010). Network coding based reliable disjoint and braided multipath routing for sensor networks. *Journal of Network and Computer Applications*, 33(4), 422-432.
- Ye, W., Heidemann, J., and Estrin, D. (2002). An energy efficient MAC protocol for wireless sensor networks. In *Proceedings of the 21st International Annual Joint Conference of the IEEE Computer and Communications Societies (INFOCOM, June, 2002)*.
- Yeo, S.-S., Park, J. H., Hsu, C.-H., and Yang, L. T. (2010). *Algorithms and Architectures for Parallel Processing: 10th International Conference, ICA3PP 2010, Busan, Korea, May 21-23, 2010. Proceedings* (Vol. 1): Springer.
- Yi, X.-S., Jiang, P.-J., Wang, X.-W., and Zhang, S.-C. (2011, Nov.). *Survey of Energy-Saving Protocols in Wireless Sensor Networks*. Proceedings of 2011 First International Conference on Robot, Vision and Signal Processing (RVSP), Kaohsiung City, Taiwan.
- Yick, J., Mukherjee, B., and Ghosal, D. (2008). Wireless Sensor Network Survey. *Computer Networks*, 52(12), 2292-2330.
- Yong, Z., and Pei, Q. (2012). A energy-efficient clustering routing algorithm based on distance and residual energy for wireless sensor networks. *Procedia Engineering*, 29, 1882-1888.
- Yu, D., Hu, Y., Xu, X. W., Huang, Y., and Du, S. (2009). An open CNC system based on component technology. *Automation Science and Engineering, IEEE Transactions on*, 6(2), 302-310.
- Yun, Y., and Xia, Y. (2010). Maximizing the lifetime of wireless sensor networks with mobile sink in delay-tolerant applications. *Mobile Computing, IEEE Transactions on*, 9(9), 1308-1318.
- Zhang, C., Hou, E., and Ansari, N. (2009). *Wireless Sensor Networks: A Networking Perspective*.
- Zhao, M., and Yang, Y. (2012). Optimization-based distributed algorithms for mobile data gathering in wireless sensor networks. *Mobile Computing, IEEE Transactions on*, 11(10), 1464-1477.
- Zheng, J. (2009). *WIRELESS SENSOR NETWORKS A Networking Perspective*. Hoboken, New Jersey: John Wiley & Sons, Inc. .
- Zhou, H., Wu, Y., Hu, Y., and Xie, G. (2010). A novel stable selection and reliable transmission protocol for clustered heterogeneous wireless sensor networks. *Computer Communications*, 33(15), 1843-1849.
- Zhu, Y., Zhou, J., Shen, X., Song, E., and Luo, Y. (2012). *Networked Multisensor Decision and Estimation Fusion: Based on Advanced Mathematical Methods*: CRC Press.





UNIVERSITY *of the*  
WESTERN CAPE

## Appendix A: Flowchart for the multi-path routing ant colony optimization

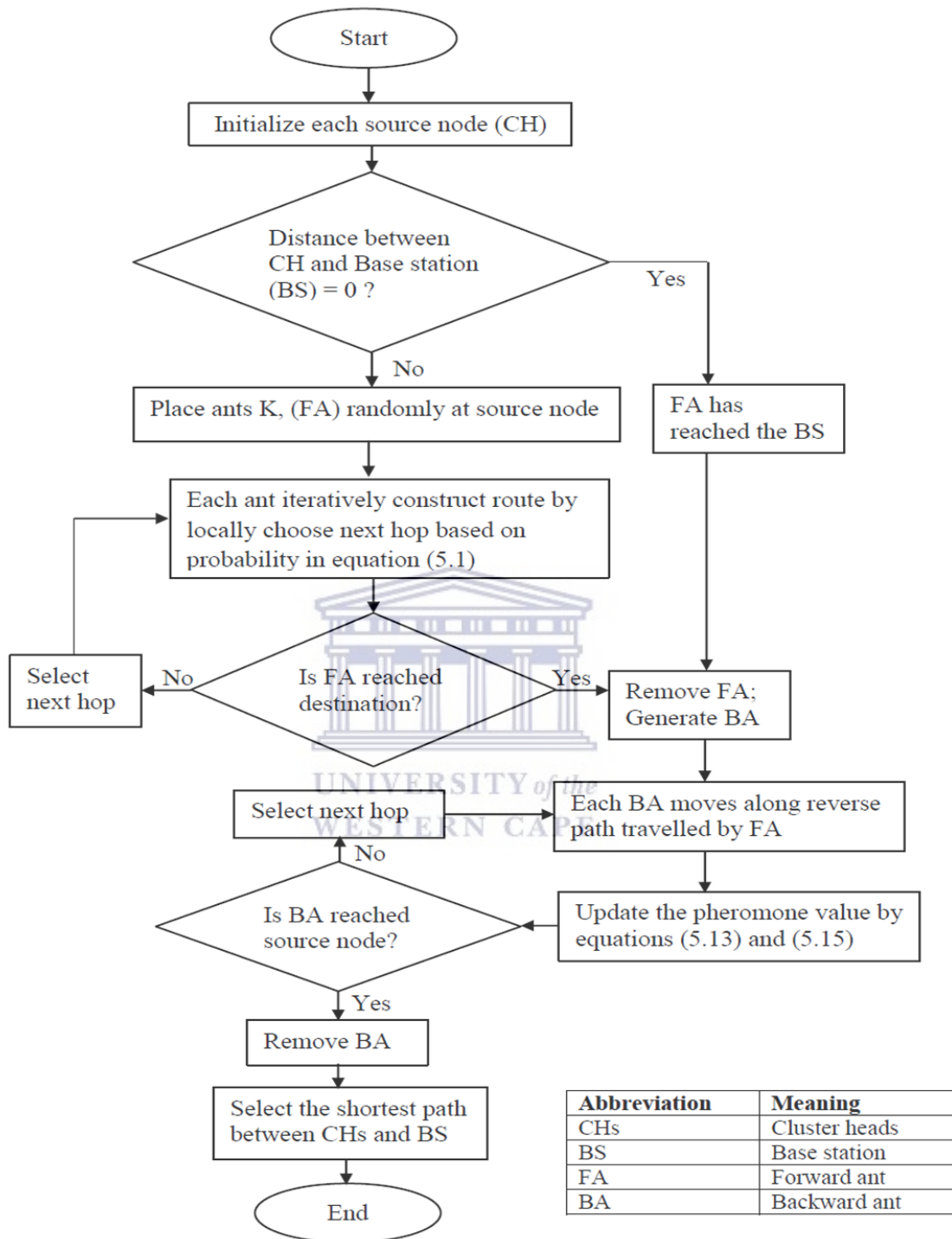

## Appendix B: Flowchart for the EOCIT routing protocol

